

760173310



RBA72-36 Battery Cabinet, 48V, VRLA/TEC

- Reduced power consumption through thermoelectric cooling
- Reduced maintenance; no compressor or filters
- Single, bulk busbar assembly
- Sealed to outside environment
- Double wall construction

Product Classification

Product Type Power back-up enclosure

General Specifications

Access Rear panels (2)

Batteries Not included

Batteries Supported 180 A-h batteries

Cabinet Type Battery back-up cabinet

Color Gray

Cooling Thermoelectric cooling

Dimensions

Height 1,828.8 mm | 72 in

Height, Battery 320.04 mm | 12.6 in

Width 914.4 mm | 36 in

Width, Battery 124.46 mm | 4.9 in

Depth 990.6 mm | 39 in

Depth, Battery 558.8 mm | 22 in

Electrical Specifications

Alarm Output Circuit breaker | High temperature | Intrusion | Thermoelectric cooling

Battery String Current, maximum 1080 A-h @ -48 Vdc

Battery Strings, quantity 6 @ -48 Vdc

Voltage -48 Vdc

Cabinet Dimensions and Door Clearances

760173310

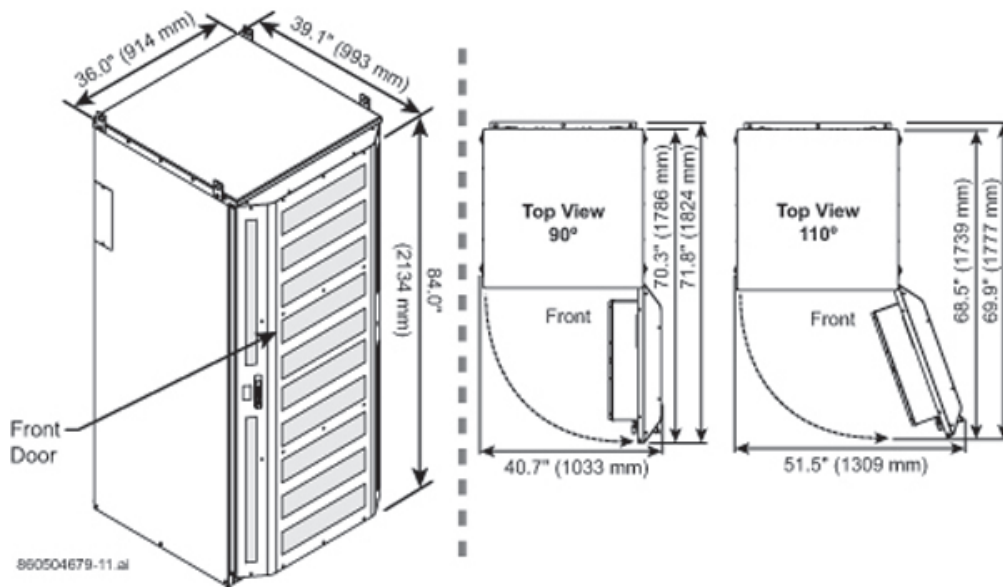

Cabinet Mounting

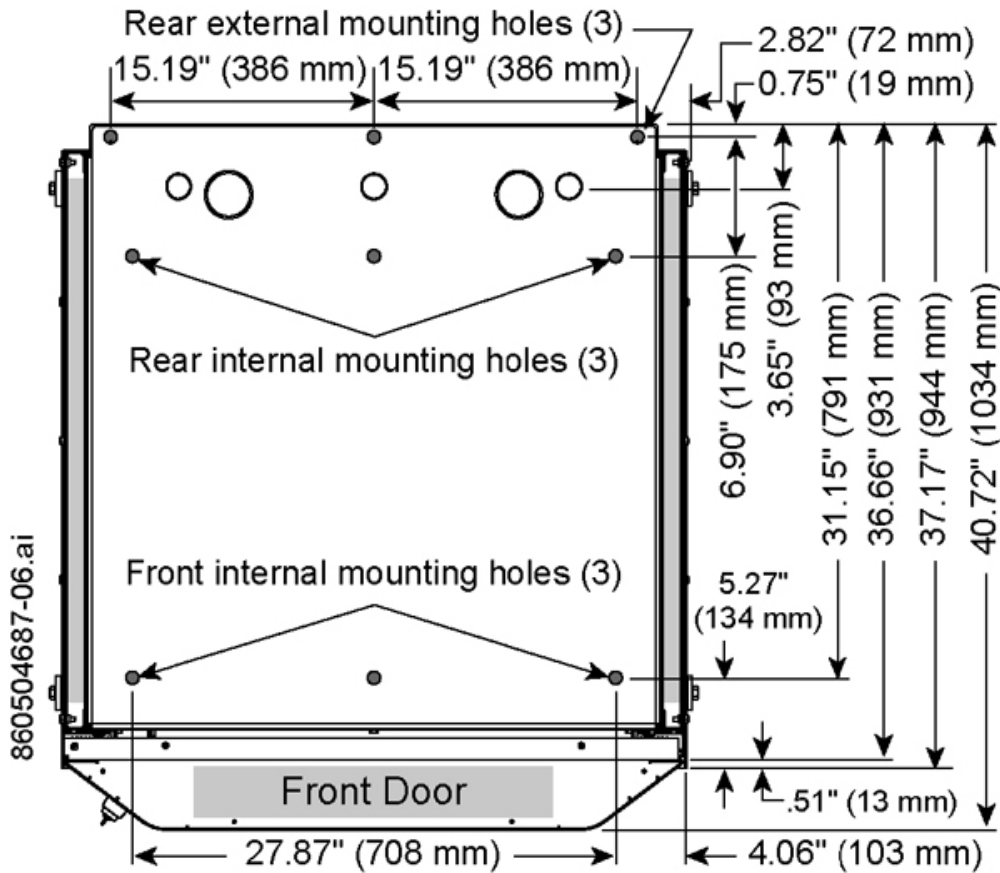

760173310

Material Specifications

Finish Powder coated

Environmental Specifications

Qualification Standards Telcordia GR-487

Packaging and Weights

Weight, net 294.835 kg | 650 lb

Weight, with batteries, typical 1,769.01 kg | 3900 lb

Regulatory Compliance/Certifications

Agency

ISO 9001:2015

Classification

Designed, manufactured and/or distributed under this quality management system

