

## SYSTIMAX® imVision® Controller X Installation

### General

The **SYSTIMAX® imVision® Controller X** units communicate with each other using the controller LAN. Modular patch cords can be used to make the controller LAN connections. The panel bus allows the **imVision Controller X** and **iPatch®** panels to communicate. Also, the **imVision Controller X** supplies power to the **iPatch** panels through the panel bus assembly. An additional backup power supply is available and a connection for it is provided on the controller. A Rack Extender Kit, sold separately, provides panel buses and jumpers to enable an imVision Controller X to manage two dependent racks in addition to the controller's rack.

This instruction sheet is available online in other languages. Instruction sheets in other languages can be found by searching for "760237876" from [www.commscope.com](http://www.commscope.com), then looking at the product page for 760237876 (imVision Controller X)

Ordering Information is listed below:

Material ID	Part No.	Description
760237876	IMV-CNTRL-X	<b>imVision Controller X</b>
760237877	IMV-CNTRL-X-AR	<b>imVision Controller X</b> (Argentina version)

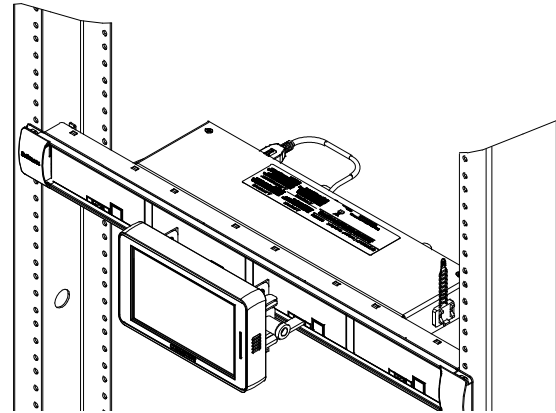

### How to Contact Us

- To find out more about **CommScope®** products, visit us on the web at <http://www.commscope.com/>

For technical assistance, customer service, or to report any missing/damaged parts, visit us at <http://www.commscope.com/SupportCenter>

### Tools Required

- Phillips head screwdriver #2

## Specifications

**Microprocessor:**

32-bit, 600 MHz ARM Cortex-A8 Processor

**Power:**

12 VDC at 24 W (Controller+ Panels)

**Programming:**

Downloadable software

**Program Data Retention Without Power:**

Minimum 10 years

**Configuration Limits:**

Maximum 45 rows of iPatch copper or 52 rows of fiber per imVision Controller X in single-rack mode

Maximum 10 rack units (RUs) of copper and iPatch panels per imVision Controller X in multi-rack mode

Maximum 50 managed racks per zone

**Recommended Mounting Height:**

Approximately 65 inches (1.7m) above the floor, measured from the top edge of the controller (the 34th 1U slot up from the bottom of a rack)

**Operational Environment:**

Temperature range: 32°F to 122°F (0°C to 50°C)

**Ethernet Interface:**

IEEE 802.3 10BASE-T

IEEE 802.3u 100BASE-TX

IEEE 802.3ab 1000BASE-T

**Status indicators:**

Amber and green LEDs indicating Ethernet link and activity

Multicolor power and status indicator light on the controller base

Multicolor attention light bar on the controller display

## Parts List

Verify parts against the parts list below:

Quantity	Description	Quantity	Description
1	Controller assembly	1	Power supply
1	Panel bus assembly	1	Installation instruction sheet
4	Mounting screws with star washers		
1	Patch cord CPC3312-03F007, 7 foot (2.1m)		



**CAUTION Read and understand all instructions.**

- When installing, operating, or maintaining **SYSTIMAX** equipment, basic safety precautions should always be followed to reduce the risk of fire, electric shock, and injury to persons.
- Follow all warnings and instructions marked on this product.
- This product should be operated using only the power supply provided by **CommScope** with the product. Consideration should be given to the connection of the equipment to the supply circuit and the effect that overloading of the circuits might have on over current protection and supply wiring. Appropriate consideration of equipment nameplate ratings should be used when addressing this concern.
- Never install this product in wet locations or during lightning storms. There is a remote risk of electric shock.
- Do not place this product on an unstable cart, stand, or table. The product may fall, causing serious damage to the product.
- When installing **SYSTIMAX** equipment not described in this guide, follow the instructions provided with that equipment. Care should be taken not to compromise the stability of the rack by installation of equipment.
- Except where indicated, never push objects of any kind into this product through slots as they may touch dangerous voltage points or short out parts that could result in a risk of fire or electrical shock. Never spill liquids of any kind on the product.
- To reduce the risk of an electrical shock, do not disassemble this product. Service should be performed by trained personnel only. Opening or removing covers and/or circuit boards may expose you to dangerous voltages or other risks. Incorrect reassembly can cause electrical shock when the unit is subsequently used.

- This product is for use in restricted access areas only.
- If this product is installed in a closed or multi-unit rack assembly, the operating ambient temperature of the rack environment may be greater than the room ambient temperature. Therefore, consideration should be given to installing the equipment in an environment compatible with the product's maximum ambient temperature (104°F or 50°C).
- Installation of the equipment in a rack should be such that the amount of airflow required for safe operation of the equipment is not compromised.
- Rack or cabinet must be grounded according to applicable local and national building codes.

**Note:** All wiring that connects to the **imVision** or **iPatch** equipment must meet applicable local and national building codes and network wiring standards for communication cable.

- Equipment not intended to be routed outside of plant.



### Important: Limitations

- Limit the chain of **iPatch** panels connected to each panel bus port to a maximum of five (5) connectors (including controller). Start a new chain of panels with every 6th panel in the rack system.
- The imVision Controller X is not compatible with iPatch Rack Manager Plus or iPatch Panel Manager.
- The imVision Controller X is not compatible with imVision Controller when used in multi-rack mode

## Separately Orderable Items

Material ID	Part No.	Description
760222448	imV-Pwr-Supply	Power supply, backup
760237878	IMV-CNTRL-X-DIS	Replacement Display
760237879	IMV-CNTRL-RK-XT	Rack Extender Kit: Contains two long 13 foot (~4.0m) panel bus jumpers, labeled as "860633124", and 2 panel buses. This kit allows dependent racks to the left and to the right of an imVision Controller X to be managed without a dedicated controller.
760241115	IMV-CNTRL-X-JMP-10	imVision Controller X Jumper Cable Kit, 10 Pack: Contains ten 48-inch (~1.2m) panel bus jumpers. Each 48-inch panel bus jumper connects an imVision Controller X to the panel bus in the the same rack.
760175463	360-imV-PB-CNTRL-5	SYSTIMAX 360™ imVision® Panel Bus, 5 Pack: Contains five panel buses.

## Step 1 – Mount Panel Bus Assembly

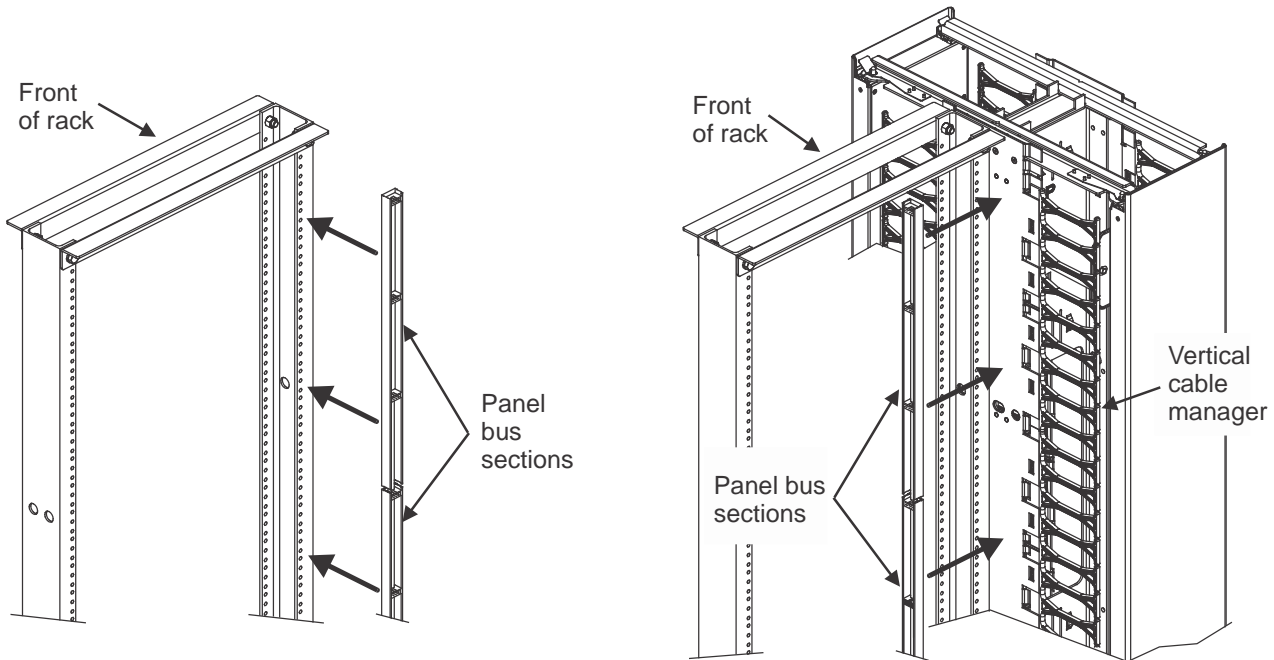

### Panel Bus Mounting on Rear Flange of Rack

### Panel Bus Mounting on Side of Vertical Cable Manager

**Note:** It is recommended the panel bus assembly be mounted on either the outside of the rear flange on the equipment rack or, if panels/shelves will be used that may block access to it, on the side of the vertical cable manager next to the rack.

1. Check the selected installation surface to be sure it is free of protrusions, such as threaded inserts, nuts, and bolts. Ensure that it is dry and clean of dust or other contaminants that may reduce adhesion.
2. Unfold the panel bus assembly (replacement MID 760175463), which is shipped folded in sections, each approximately 19 inches (483mm) long.
3. Orient the panel bus assembly so the section with the connection point closest to the end is at the top of the rack.
4. One section at a time, remove the adhesive backing and press the panel bus assembly firmly against the installation surface.

## Step 2 – Install Controller on Rack

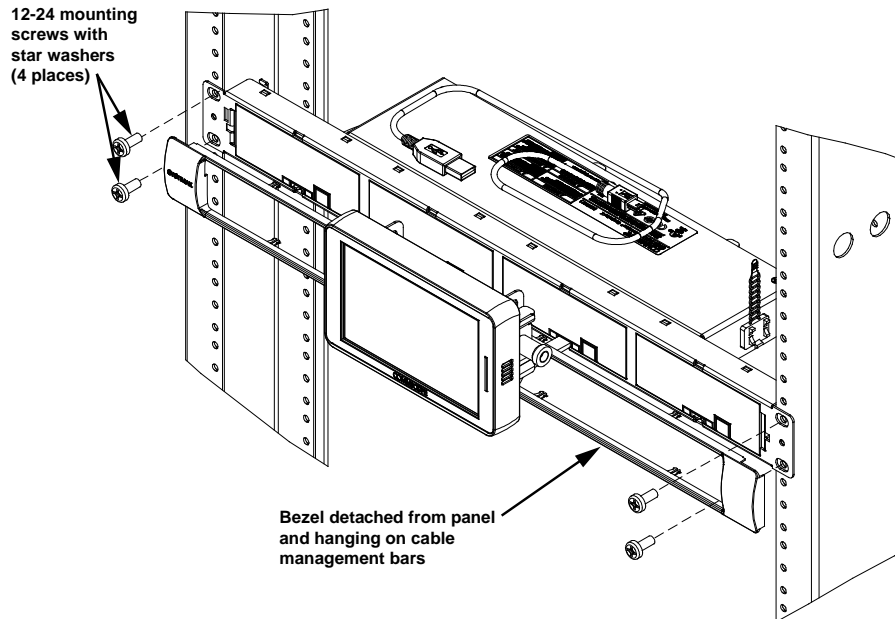

**Note:** imVision Controller X is pre-assembled with cable management bars in holes closest to the front. This is the standard position for use with copper panels. Test fit the controller for interference with panels above and below and adjust cable management bars as needed to minimize interference. The cable management bars are held in place by screws on the bottom of the panel. These must be completely removed to reposition the bars.

1. Remove bezel from front of panel by pulling on the left and right side of the bezel. The bezel will pop off of the metal base. Leave bezel hanging on cable management bars as shown above.
2. Using the four provided screws with star washers, install controller panel on rack. Slide bezel from side to side to gain access to screw positions.

**Note:** If not using provided screws with star washers, Always use screws with star washers when securing the controller panel to rack. The star washers are needed to ensure a proper grounding connection between rack and controller. Special grounding cage nuts are also recommended where cage nuts are used.

**Note:** It is recommended to use the 34<sup>th</sup> 1U slot up from the bottom of the rack so that the top of the unit is about 65 inches (1.7m) above the floor.

3. Reinstall bezel on front of panel.

## Adjustment of Display Unit

**Note:** The height of display unit can be adjusted by loosening retainer pin fastener and sliding the display unit up or down. Re-tighten fastener to secure display position.

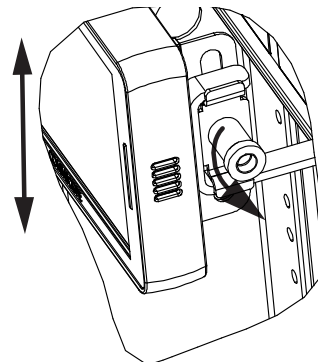

### Step 3 – Connect Panel Bus Jumper and USB Cable

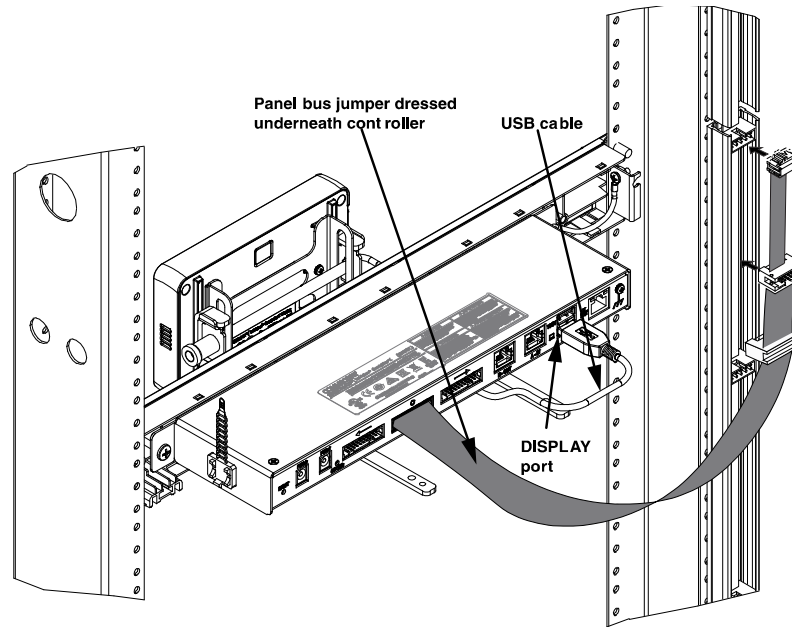

1. Unfold pre-connected panel bus jumper from under controller and insert female 10-pin connector into the middle panel bus port on panel bus assembly.
2. Install spare port built into jumper cordage into panel bus frame by turning it at an angle, inserting into frame, and turning it back perpendicular to frame.
3. Ensure panel bus jumper is inserted in the three adhesive clips provided on bottom of controller.
4. Unfold pre-connected USB cable from under controller and plug connector into DISPLAY port  on rear of controller.

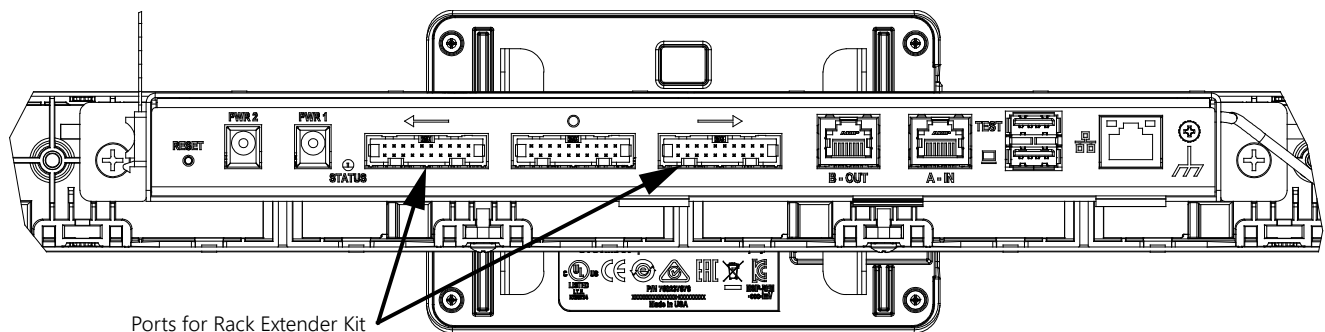

No cables are shown, detail provided to show port layout

### 3a) Support for up to three adjacent racks

**Note:**

1. Only adjacent racks are supported for this configuration
  2. Use only components provided in the Rack Extender kit
- 
- 1) Use panel bus from Rack Extender Kit to mount it on the rack to the left and/or right of the rack with the imVision Controller X installed in it. (see Step 1 for mounting instructions)
  - 2) Connect the jacketed panel bus jumper to the panel bus port labeled “←” “when connecting to the rack on the left and/or the panel bus port labeled “→” for the rack on the right (When facing the back of the imVision Controller X.
  - 3) Route the jacketed panel bus cable to the correct adjacent associated rack and plug into the panel bus port in the middle of the panel bus.

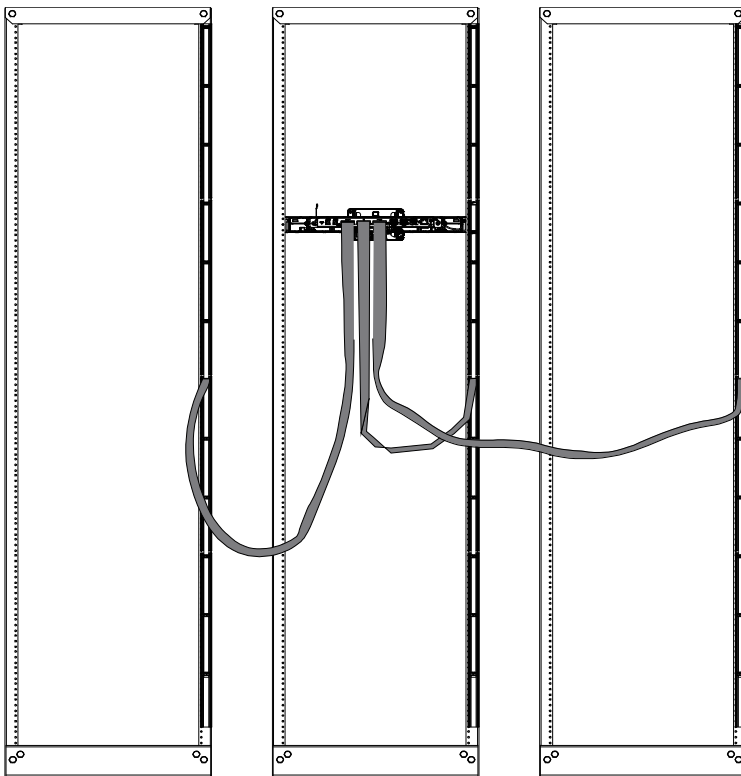

## Step 4 – Connect Power Supply

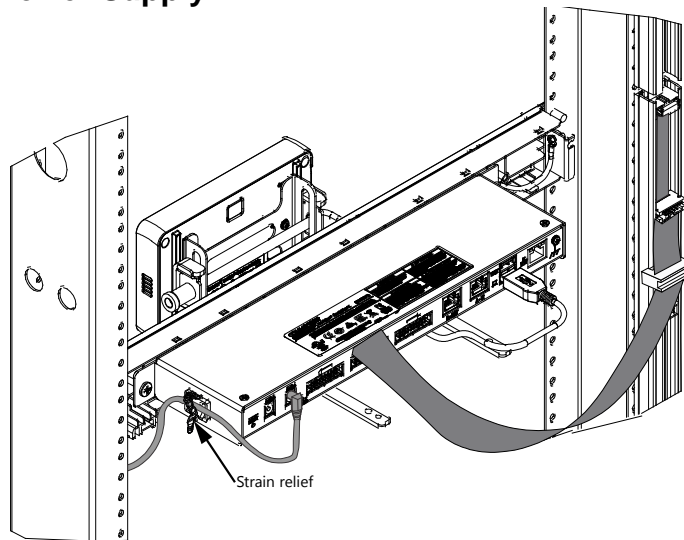

1. Connect the power supply barrel connector into PWR1 port on the rear of the controller as shown and loop cord into the provided strain relief on the side of controller.

**Note:** A connection is provided on the controller to connect a redundant or backup power supply. A redundant power supply can be attached to the PWR2 jack on the back of the **imVision Controller X**. When using a redundant power supply, use the strain relief strap to secure both power adapter cords to the side of the controller.

## Step 5 – Daisy chain controllers to create a zone

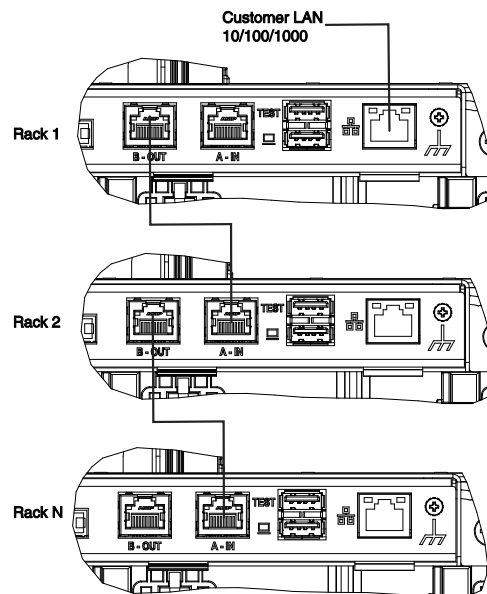



## Step 6 – Power Up imVision Controller X

1. Modify the power adapter for use with the local configuration for electrical service outlets:

- Select the appropriate AC plug.

Insert the tabbed edge of the AC plug into the top of the opening in the power adapter. Then press on the plug until it snaps into place.

2. Plug the power adapter into an electrical service outlet.
3. Power up **imVision Controller X** and configure settings and panels per the System Manager User Guide.

Please go to the **CommScope** eCatalog to download the **SYSTIMAX imVision System Manager User Guide** for features and settings.

### Included AC plugs:



### INPUT CONNECTOR OPTIONS

- 1 - NORTH AMERICAN: NEMA 1-15P CLASS II, 2 PINS, Q-NA(R)
- 2 - AUSTRALIAN CONFIGURATION: SAA 2 PINS CLASS II, Q-SAA(R)
- 3 - UK CONFIGURATION: UK 2 PINS CLASS II, Q-UK(R)
- 4 - EUROPEAN CONFIGURATION: EUROPLUG 2 PINS, CLASS II, Q-EU(R)
- 5 - KOREAN CONFIGURATION: Q-KR(R) KS C8305, 2 PINS, CLASS II
- 6 - ARGENTINA CONFIGURATION: Q-AR(R) IRAM 2073, 2 PINS, CLASS II
- 7 - Q-C18 IEC 320/C18 INLET



1



2



3



4



5



6



7

---

## Open Source Software

This product contains open source software components. Please review the *SYSTIMAX® imVision® Controller X Open Source Software Catalog* document, which can be found by searching for “imVision Controller X Open Source Software” from [www.commscope.com](http://www.commscope.com). This document includes the applicable open source software licenses and acknowledgments, as well as instructions for how to obtain component source code per each component’s license requirements.

## Trade-marks

All trademarks identified by ® or ™ are registered trademarks or trademarks, respectively, of CommScope, Inc. This document is for planning purposes only and is not intended to modify or supplement any specifications or warranties relating to CommScope products or services. CommScope is committed to the highest standards of business integrity and environmental sustainability, with a number of CommScope’s facilities across the globe certified in accordance with international standards, including ISO 9001, TL 9000, and ISO 14001.

Further information regarding CommScope’s commitment can be found at [www.commscope.com/About-Us/Corporate-Responsibility-and-Sustainability](http://www.commscope.com/About-Us/Corporate-Responsibility-and-Sustainability).

## Contact information

Visit our website or contact your local CommScope representative for more information.

For technical assistance, customer service, or to report any missing/damaged parts, visit us at:

<http://www.commscope.com/SupportCenter>

This product is covered by one or more U.S. patents or their foreign equivalents. For patents, see

[www.commscope.com/ProductPatent/ProductPatent.aspx](http://www.commscope.com/ProductPatent/ProductPatent.aspx)

### CommScope, Inc.

Attn: imVision® Support

1300 E. Lookout Dr., Suite 150

Richardson, TX 75082