

Fiber Entrance Cabinet (FEC)



FST-XD-MT Splice Tray in FEC

Content	Page
INTRODUCTION	2
1 DESCRIPTION	2
2 SPECIFICATIONS	4
3 UNPACKING AND INSPECTION	5
4 FEC MOUNTING	5
4.1 Mounting the FEC on Unistrut Brackets	5
4.2 Mounting the FEC on a Wall	7
5 CABLE ROUTING OVERVIEW	9
6 CABLE INSTALLATION	12
6.1 Cable Breakout and Positioning on Frame	12
6.2 Clamping the Cable	13
7 ROUTING FIBERS IN SPLICE DRAWERS	15
8 OPERATION	20
9 CONTACT INFORMATION	20

INTRODUCTION

This user manual describes the Fiber Entrance Cabinet (FEC) and explains how to install and use this product. The different cable types available for use in the FEC require a variety of accessory kits. Each kit contains its own installation instructions.

Related Publication

Table 1 lists technical publications for related products. These publications are available by contacting the CommScope Support Center at <https://www.commscope.com/SupportCenter>

Table 1: Recent Publications

Title	Number
Fiber Cable Breakout and Moisture Blocking Kit for Armored Uni-Tube Cable Installation Instructions	ADCP-93-039
Fiber Cable Breakout and Moisture Blocking Kit for Dielectric Uni-Tube Cable Installation Instructions	ADCP-93-064
Ground Clamp and Moisture Blocking Kit for Loose Tube Cable Installation Instructions	ADCP-93-045
Three Tier Cable Clamp Kit (OSP-CLPFEC) Installation Instructions	ADCP-93-035
Three Tier Cable Clamp Kit (OSP-CLPFEC-LG) Installation Instructions	ADCP-93-080
Ribbon Cable Breakout Kits (RIBCBOU User Manual	TC-96271-IP

Admonishments

Important safety admonishments are used throughout this manual to warn of possible hazards to persons or equipment. Admonishments — in the form of Dangers, Warnings, and Cautions — must be followed at all times.

Warning! *Warning is used to indicate the presence of a hazard that can cause severe personal injury, death, or substantial property damage if the hazard is not avoided.*

Caution! *Caution is used to indicate the presence of a hazard that will or can cause minor personal injury or property damage if the hazard is not avoided.*

Danger! *Danger is used to indicate the presence of a hazard that will cause severe personal injury, death, or substantial property damage if the hazard is not avoided.*

1 DESCRIPTION

The Fiber Entrance Cabinet (FEC) is a wall- or strut-mounted cabinet providing a compact and efficient splicing interface for optical fiber cables in a building equipment area. The FEC provides storage and protection in addition to splicing. The FEC is available in four sizes, FEC-6, FEC-12, FEC-24, and FEC-36, shown in [Figure 12](#) and [Figure 13](#).

The FEC can be used with either stranded or ribbon fiber. When used with stranded fiber, each splice drawer accommodates one or two trays (up to 48 splices). When used with rollable ribbon fiber, each drawer accommodates one tray (up to 288 mass fusion splices).

Cable access ports are located at the top, bottom, and on both sides of the cabinet. Pre-formed rubber grommets are provided in each cable access port. The grommets have micro slits that can be easily cut out to match cable diameter. Each grommet can handle up to three cables.

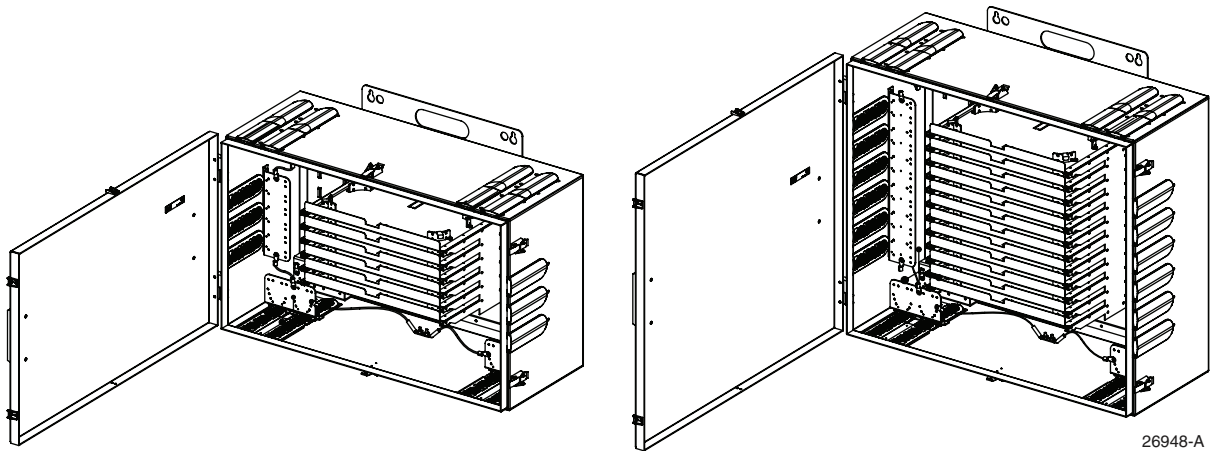

Figure 1. FEC-6 and FEC-12

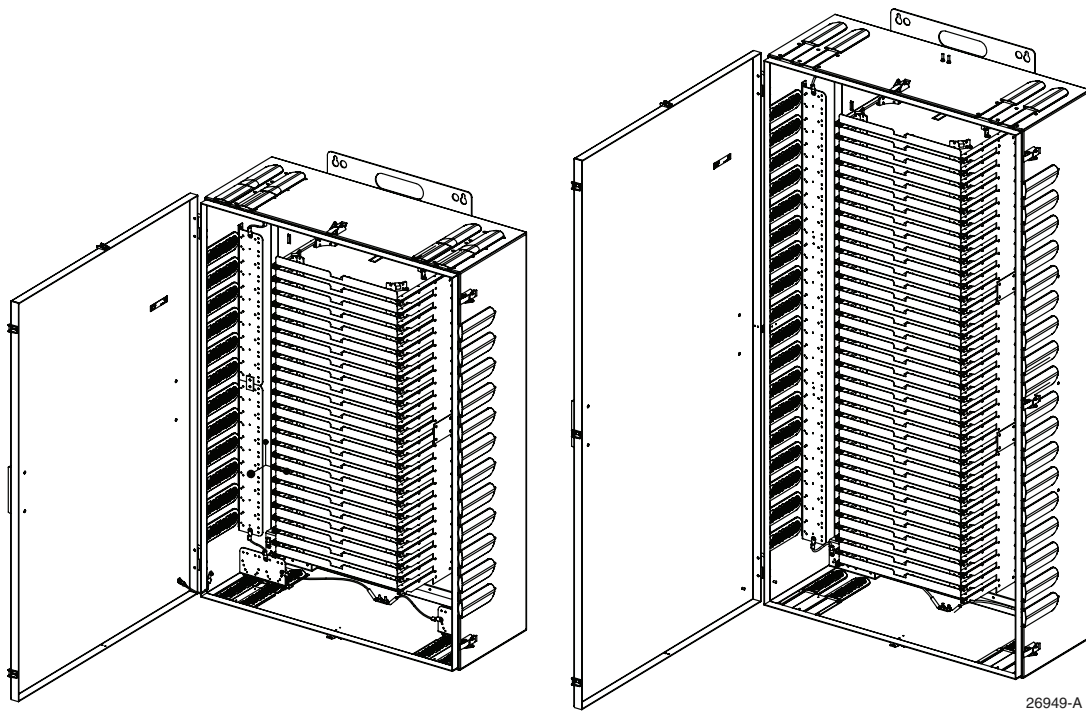

Figure 2. FEC-24 and FEC-36

Terminating and grounding plates provide cable clamp and ground connection points for cables spliced in the cabinet. The door hinges are split and allow the door to be removed for full access to the cabinet. The door is secured with over-center draw latches that are designed to accommodate padlocks for additional security.

Figure 3 shows the interior components of the FEC-12. The other sizes of FEC are basically the same internally, except for the number of splice drawers and the number of cable access ports. There are eight top and bottom cable access ports for all cabinet sizes. There are 6, 12, 24, and 36 side access ports for the FEC-6, FEC-12, FEC-24, and FEC-36, respectively.

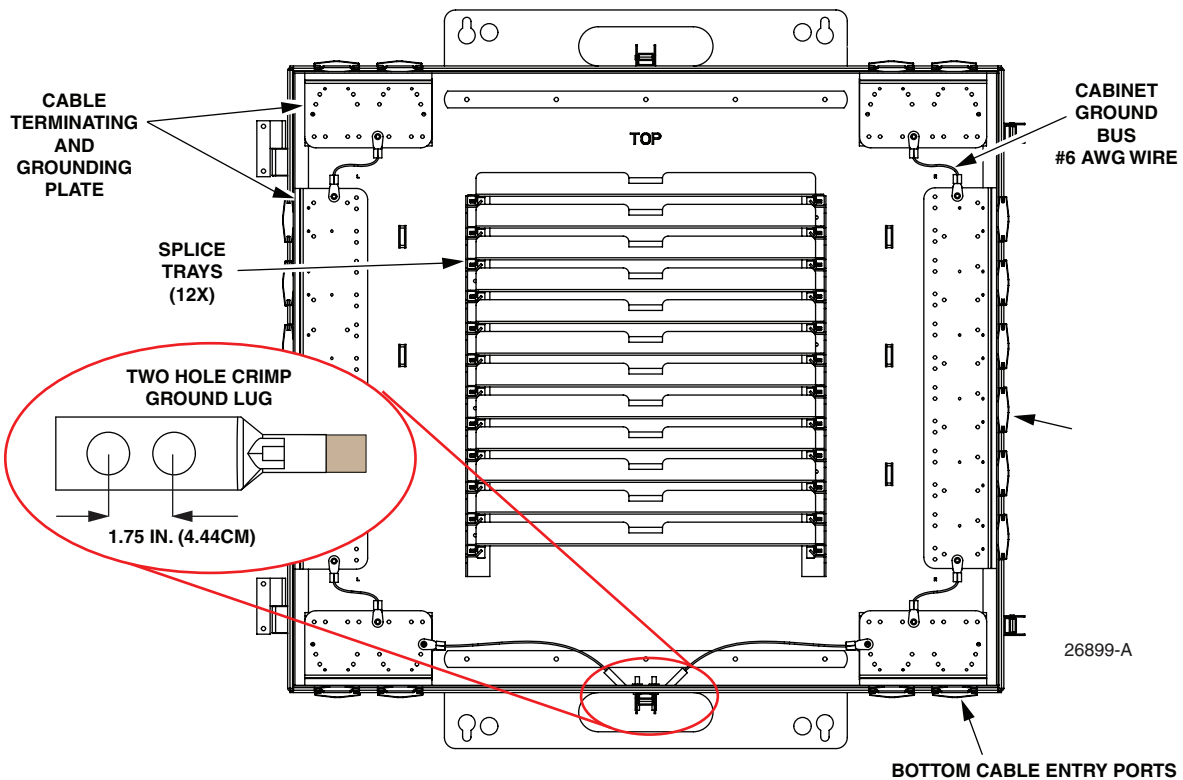

Figure 3. Interior Components of FEC-12

2 SPECIFICATIONS

Table 2 lists specifications for the FEC.

Table 2: FEC Specifications

Parameter	FEC-6	FEC-12	FEC-24	FEC-36
Height	19.5 in. (49.5 cm)	28 in. (71.1 cm)	45 inches (114.3 cm)	62 in. (157.5 cm)
Width	32 in. (81.3 cm)	32 in. (81.3 cm)	32 in. (81.3 cm)	32 in. (81.3 cm)

Table 2: FEC Specifications

Parameter	FEC-6	FEC-12	FEC-24	FEC-36
Depth	13.5 in. (34.3 cm)	13.5 in (34.3 cm)	13.5 in. (34.3 cm)	13.5 in. (34.3 cm)
Weight (approx.)	50 lb (22.7 kg)	80 lb. (36.3 kg)	120 lb. (54.4 kg)	160 lb. (72.6 kg)
Side ports	6	12	24	36

3 UNPACKING AND INSPECTION

1. Inspect the exterior of the shipping container(s) for evidence of rough handling that may have damaged the components in the container.
2. Unpack each container while carefully checking the contents for damage.
3. If damage is found or parts are missing, contact the CommScope Support Center using the URL:
<http://www.commscope.com/SupportCenter>
4. Save any damaged cartons for inspection by the carrier.

4 FEC MOUNTING

The FEC may be wall mounted or mounted to Unistrut. The mounting materials such as backboard, anchors, bolts, and Unistrut materials are not provided.

When determining the wall mounting locations, consider the following recommendations:

- Place cable racks a minimum of 10 inches (25.4 cm) from each side of the FEC.
- Use 5-inch (12.7 cm) cable rack for FEC-6 and FEC-12 cabinets and 10-inch (25.4 cm) cable rack for FEC-24 and FEC-36 cabinets.
- Allow at least 24 inches (61 cm) from the floor to the bottom of the FEC-12, FEC-24 and FEC-36 cabinets. Allow 36 inches (91.4 cm) for the FEC-6 cabinet.
- FEC-6 and FEC-12 cabinets may be stacked. If stacking FEC-12 cabinets, use 10-inch (25.4 cm) cable rack.

Do not stack FEC-24 and FEC-36 cabinets.

Note: A CommScope Uni-bracket is required in the following procedure and must be separately ordered (catalog #FEC-UNIBKT: ACC BKT FEC UNISTRUT BLK).

4.1 Mounting the FEC on Unistrut Brackets

The vertical wall racks and Unistrut materials used in the following procedure are not provided and are not available from CommScope.

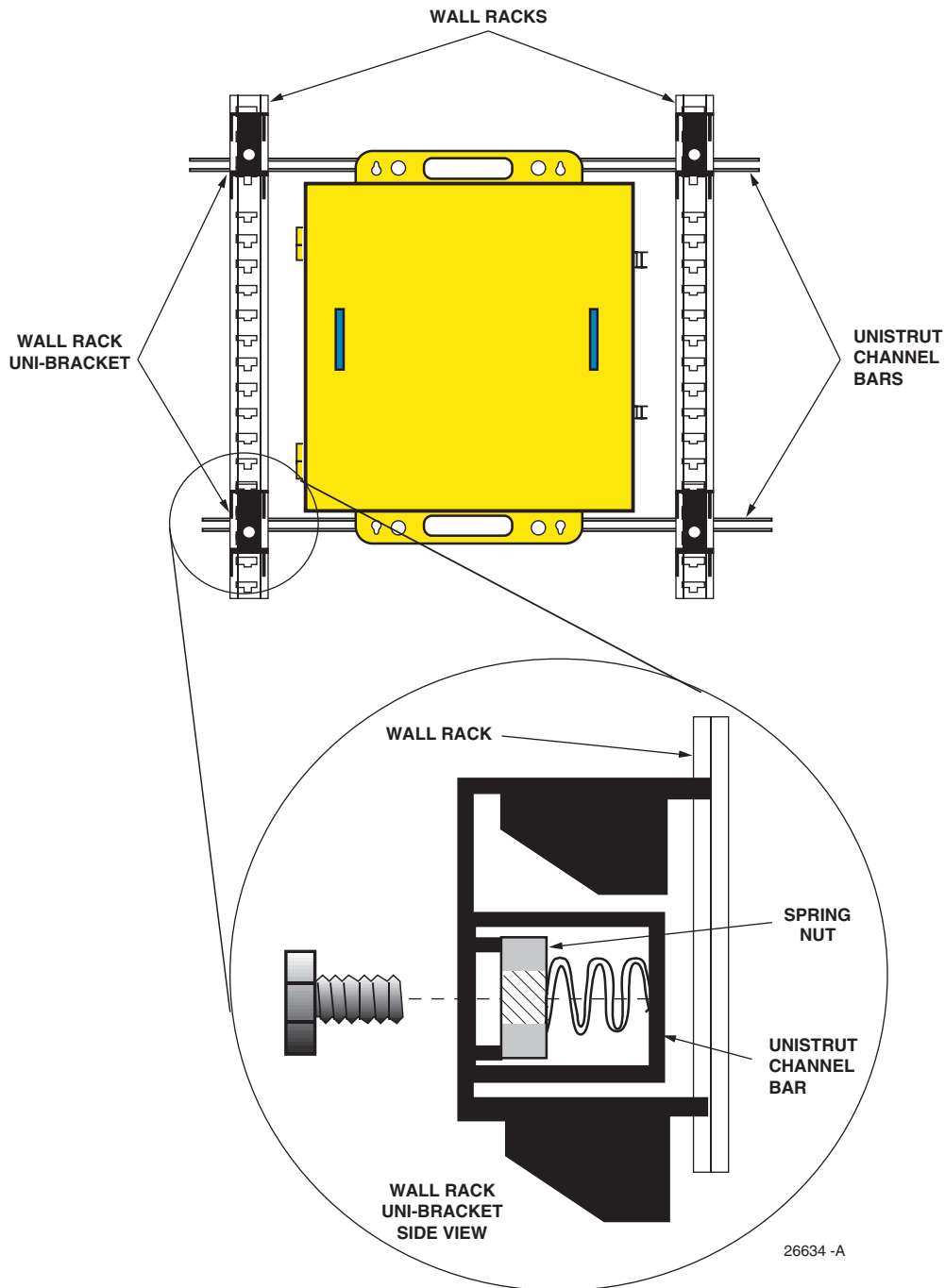

Figure 4. Unistrut Mounted FEC-12

The Uni-bracket used in the procedure is available from CommScope, but must be ordered separately (see **Note** above for catalog number). It is recommended to use 0.50-inch (12.7 mm) and 0.25-inch (6.35 mm) size bolts and spring nuts.

Refer to [Figure 4](#) and the following instructions to mount the cabinet:

1. Determine the location for the cabinet and insert the Uni-brackets in the wall rack.
2. Position two 0.50-inch (12.7 mm) Unistrut spring nuts in each Unistrut channel bar. Locate the spring nuts at the approximate position of the Uni-bracket hole and the FEC mounting holes.
3. Insert the Unistrut channel bars through the Uni-brackets.
4. Thread a 0.50-inch (12.7 mm) mounting bolt through each Uni-bracket into the Unistrut spring nuts. Align the Unistrut channel bars and tighten the bolts.
5. Place two 0.25-inch (6.35 mm) Unistrut spring nuts into the top Unistrut channel bar. Thread two 0.25-inch (6.35 mm) mounting bolts into the Unistrut spring nuts.
6. Place the FEC top mounting holes (keyholes) over the bolts. Position the FEC and tighten the bolts.
7. Place two 0.25-inch (6.35 mm) Unistrut spring nuts into the bottom Unistrut channel bar. Thread two 0.25-inch (6.35 mm) mounting bolts through the FEC bottom mounting holes into the Unistrut spring nuts and tighten.
8. Prepare a ground lead from central office ground to the FEC. Use #6 AWG wire and attach to a two hole crimp type lug (wire and lug not provided). Connect to the ground posts at the bottom of the FEC. Refer to [Figure 4 on Page 6](#).
9. Attach cable designation labels on each splice drawer for cable assignments.

4.2 Mounting the FEC on a Wall

The FEC may be mounted on a stable flat vertical surface.

A backboard material (not provided) such as 0.75-inch (1.9 cm) thick plywood, applied to a wall, provides a suitable mounting surface. The choice of fasteners is governed by local practice.

It is recommended to use, as a minimum, 0.375-inch (9.5 mm) diameter lag bolts and/or anchors. If mounting on a hollow frame, wall backboard on both sides and through bolts are recommended.

If the FEC is mounted directly to a concrete wall with anchors, ensure that the wall is straight so that when the fasteners are tightened the cabinet shape is not distorted. Shims may be required. The door must fit square to provide a water resistant seal.

The position of the FEC must allow enough space on all sides to bring the fiber cables in without exceeding the minimum bend radius for the cable. The standard rule for cable bend radius is, the bend radius should be equal to or greater than ten times the cable diameter. Always allow enough space between FECs based on the largest cable that will be installed.

Before mounting the FEC, determine what the configuration will be for the particular cabinet being installed. This is an especially important step when installing cables into a larger size cabinet such as the FEC-36. Cables can enter from above or below the rack, and from either side. Use the following procedure to wall mount each FEC.

1. Determine the FEC mounting location. Mark hole positions using dimensions shown in [Figure 5](#).

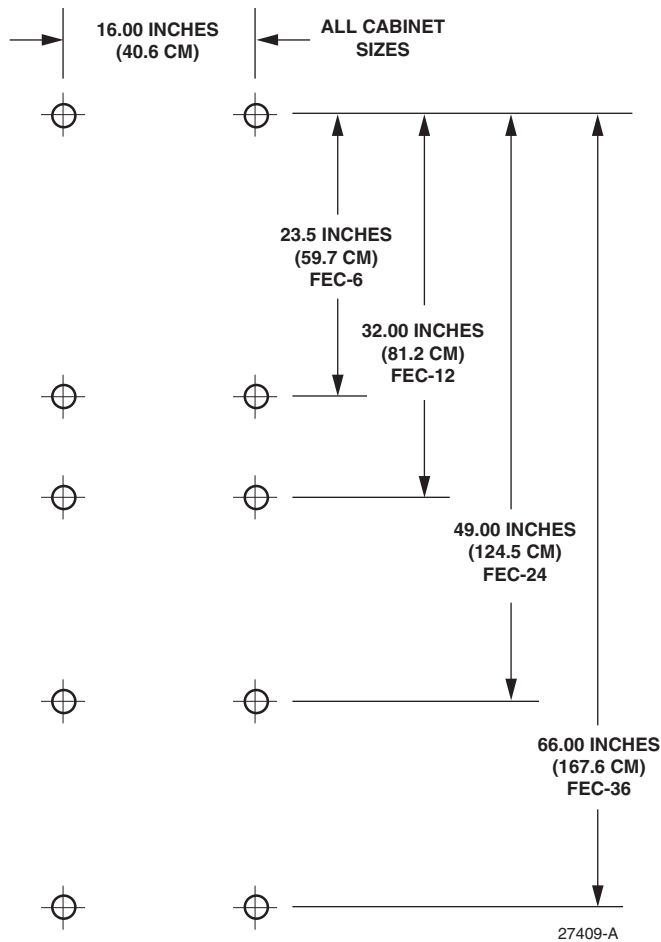

Figure 5. Mounting Hole Locations

2. Drill four holes for anchor bolts (or moly bolts) in the backboard or four holes in a concrete wall for anchors at the points marked in Step 1. If using anchors place the anchors in the holes.
3. Partially install two mounting bolts (not provided) in the top holes.
4. Place the FEC top mounting holes (keyholes) over the bolts.
5. Insert two bolts into the bottom mounting holes. Tighten all bolts.
6. Prepare a ground lead from central office ground to the FEC. Use #6 AWG wire and attach to a two hole crimp type lug (wire and lug not provided). Connect to the ground posts at the bottom of the FEC.
7. Attach cable designation labels on each splice drawer for IFC and OSP cable assignments.

5 CABLE ROUTING OVERVIEW

Cables may enter the FEC from above, below, or from either side. Cables may include high-count cables, usually of ribbon construction, and lower-count cables, usually of stranded construction. Figure 6 shows an example of a high count application. In this bottom entry example, the cables are of a ribbon construction and each cable breakout is positioned alongside the groups of drawers that the cable is assigned to. Each cable has six sub-units, which are each assigned to one splice drawer

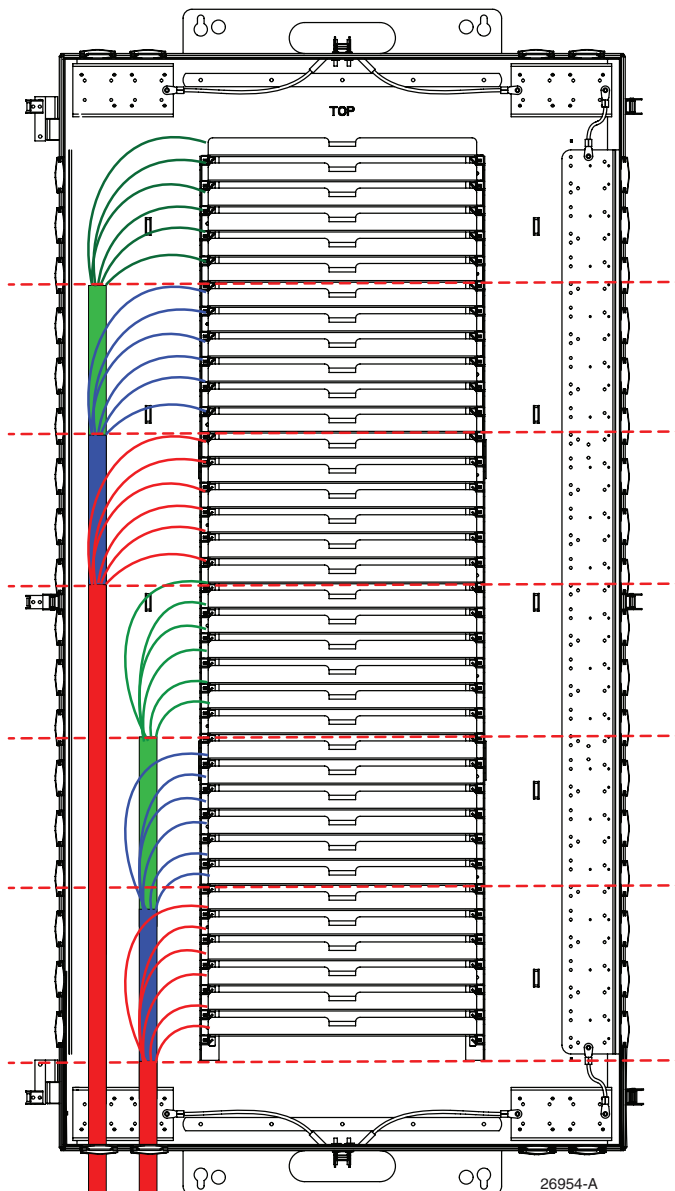

Figure 6. High-Count Cable Configuration Example

Figure 7 shows an example of a lower count application. In this top entry example, the cables are of stranded construction and are broken out just below the cable clamps.

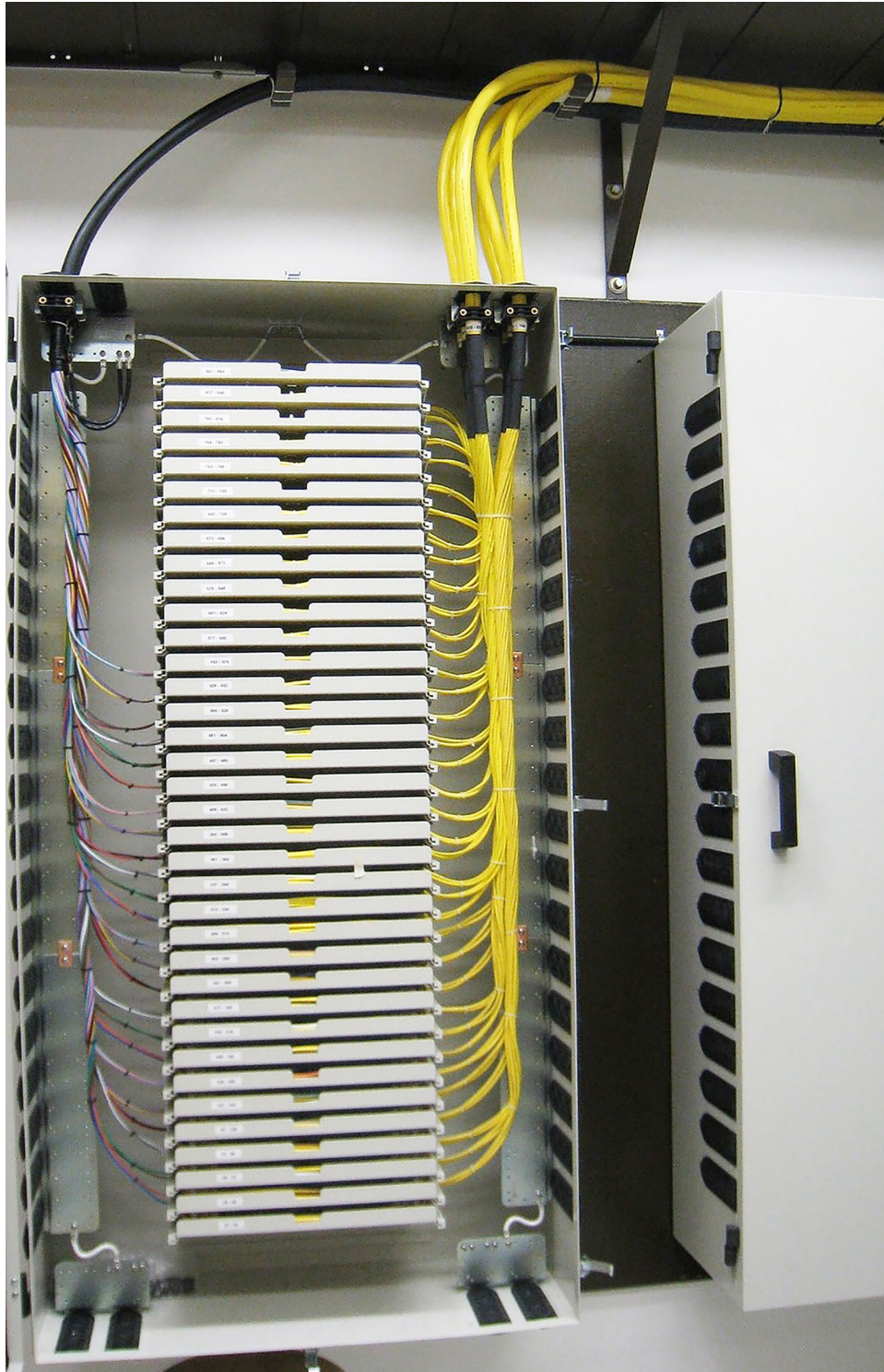

Figure 7. Stranded Cable Configuration Example

Figure 8 show details of the top cable entry. Figure 11 shows an example of bottom entry on the left side of the cabinet and side entry on the right side.



Figure 8. Detail of Top Entry Cables



Figure 9. Bottom and Side Entry Example

6 CABLE INSTALLATION

6.1 Cable Breakout and Positioning on Frame

In breaking out and positioning cables on the frame, adhere to the following guidelines.

- Consider each cable to correspond to one “zone” of the frame.
- Divide fiber count of the cable by 288 to determine number of trays within each zone.
- Position cable breakout at edge of zone (bottom edge if bottom entry, top edge if top entry).
- Break out cable accordingly per local practice.

Figure 10 shows bottom entry of three 3456-fiber cables.

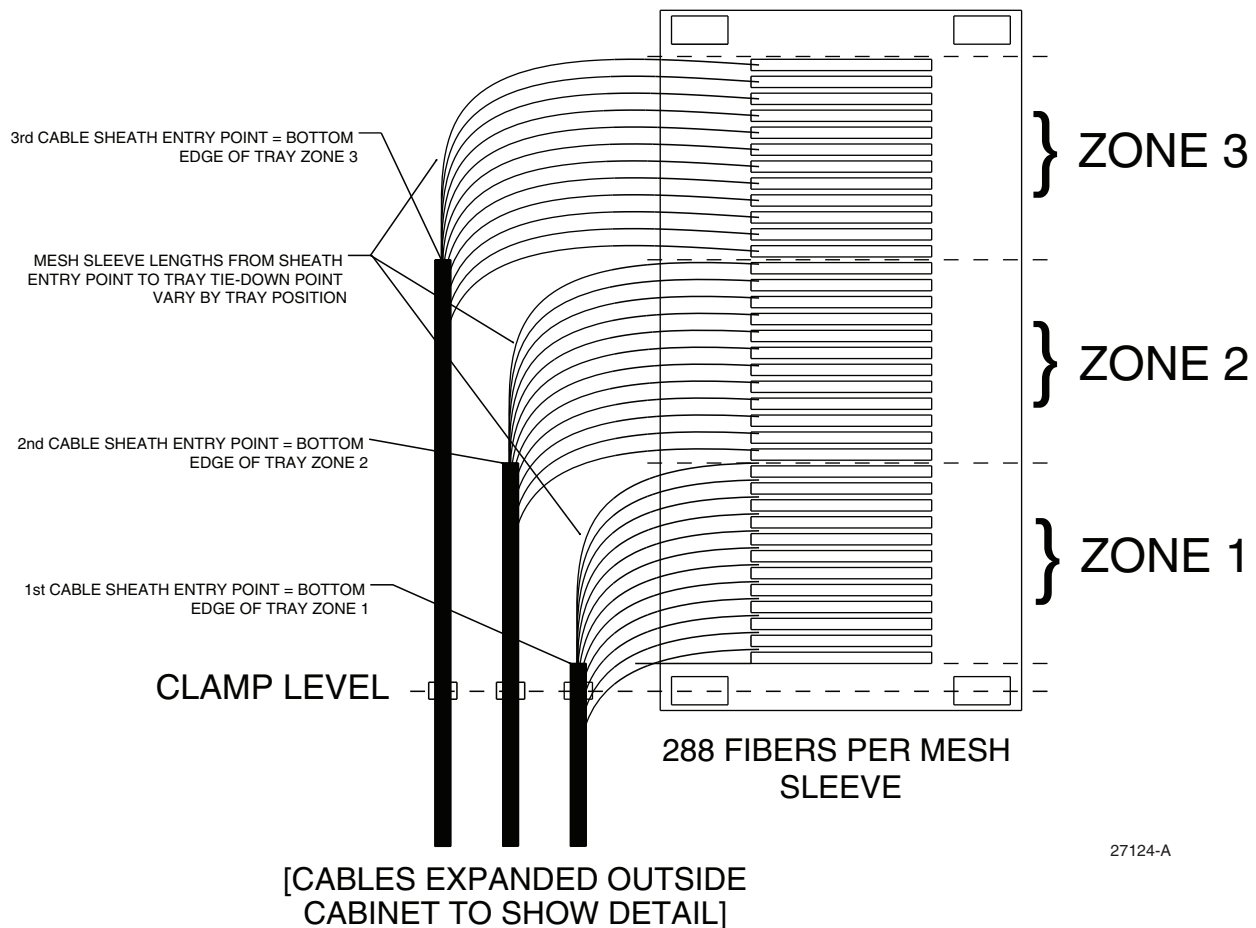

27124-A

Figure 10. Example #1: Bottom Entry, Three 3456-Fiber Cables

Figure 11 shows top entry of twelve 864-fiber cables with three-way flareout assemblies. Mesh sleeve material is used as indicated to protect the cable sub--units from cable sheath breakout to the fanouts.

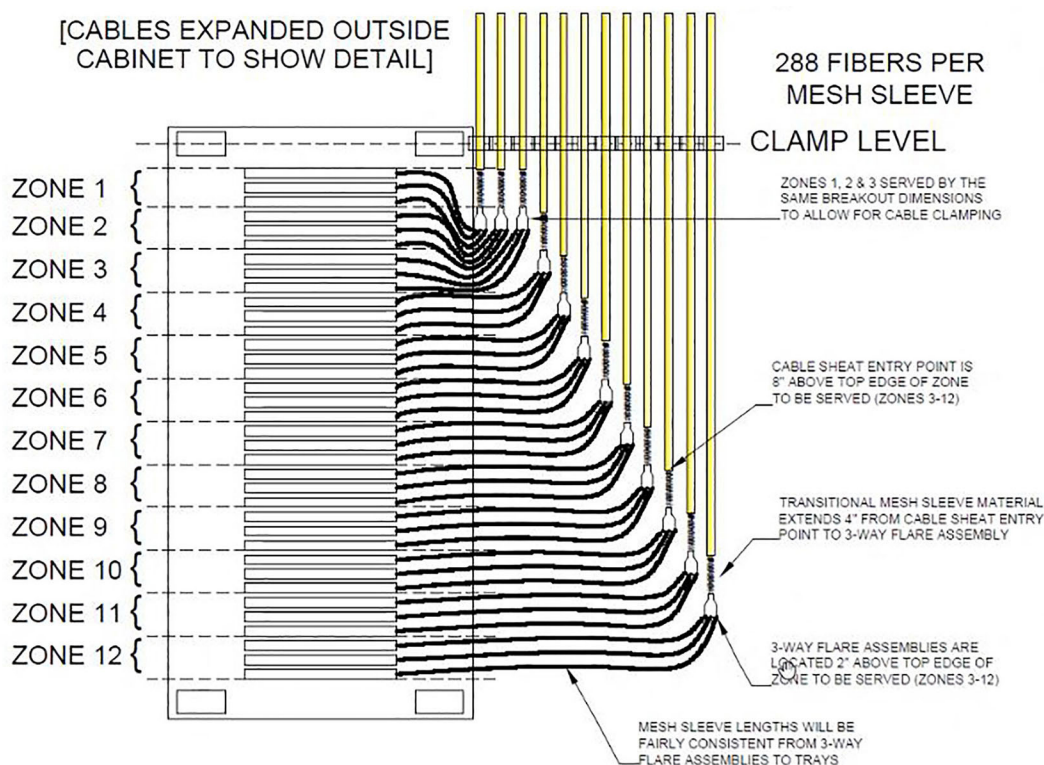

Figure 11. Top Entry, Twelve 864-Fiber Cables With Three-Way Flare Assemblies

6.2 Clamping the Cable

At the cable entry location, install an appropriate cable clamp for the cable type and size. [Table 3](#) lists the cable clamps that may be used..

Table 3: Cable Clamping Kits Used With FEC

Catalogue Number	Description
	IFC/OSP cable clamp kit for wall mount configurations. Secure three cables to a single cable entry point on the cabinet. Clamp kits can be separated and used as single clamps
OSP-CLPFEC-LG	Cables with a maximum diameter of 10 mm (0.4") to 30 mm (1.2")
OSP-CLPFEC	Cables with a maximum diameter of 5 mm (0.2") to 18 mm (0.7")
	Individual IFC/OSP cable clamp for wall mount configurations. Secure one cable to a single cable entry point on the cabinet
OSP-CLPSST	Cables with a maximum diameter of 5 mm (0.2") to 18 mm (0.7")
	Individual IFC/OSP cable clamp for rack or wall mount configurations. Secure one cable to a single cable entry point on the cabinet
FEC-ACCCLMP01	Cables with a maximum diameter of 10 mm (0.4") to 30 mm (1.2")
	Individual soft IFC only cable clamp for wall mount configurations. Secure one cable to a single cable entry point on the cabinet.

Table 3: Cable Clamping Kits Used With FEC, continued

Catalogue Number	Description
OSP-CLPSST-IFCL	Cables with a maximum diameter of 20 mm (0.8") to 28 mm (1.1")
OSP-CLPSST-IFCS	Cables with a maximum diameter of 5 mm (0.2") to 18 mm (0.7")
	OSP cable clamp kit for wall mount configurations (except the FEC-6). Secure one cable to a single cable entry point on the cabinet (kit of 6)
OSP-CLPFEC-XL	Cables with a maximum diameter of 32mm (1.25") to 38mm (1.5")

Figure 12 shows a cable clamp example. Some kits allow multiple cables to be stacked. Figure 13 shows an example of stacked cable clamps. Install the cable clamp and install the cable within the cable clamp referring to the installation instructions provided with the cable clamp.

Finger tighten only so that the cable can be slid back and forth within the clamp as needed while the cable is broken out and positioned within the cabinet

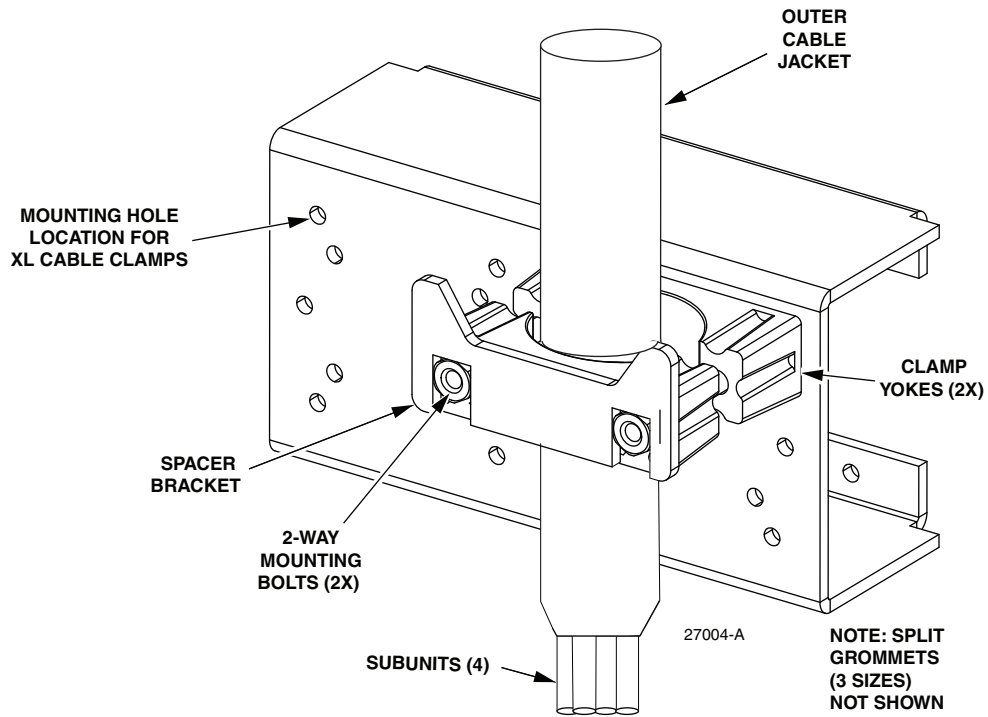

Figure 12. Rear Top and Bottom Cable Mounting Brackets

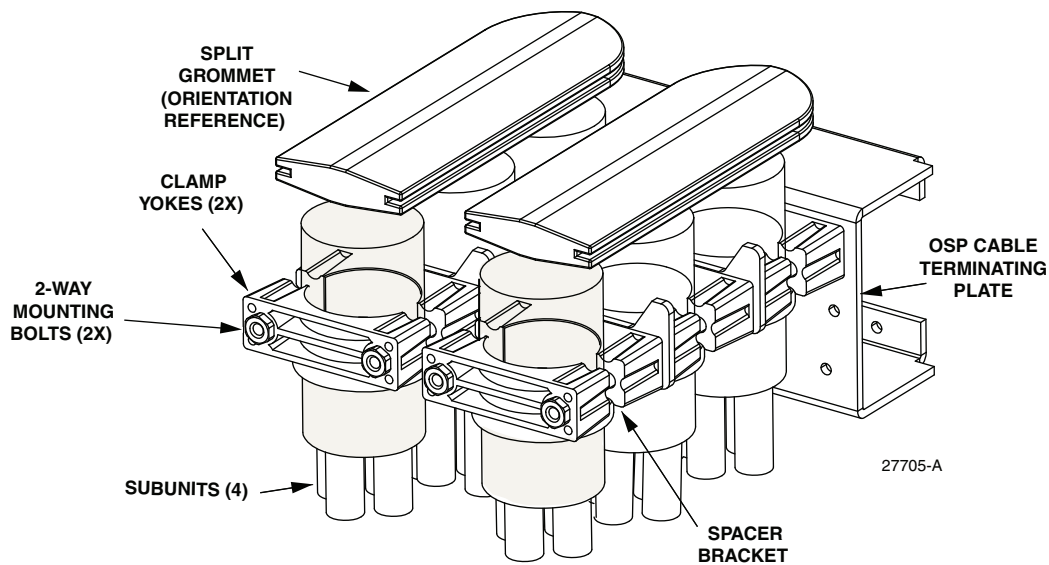
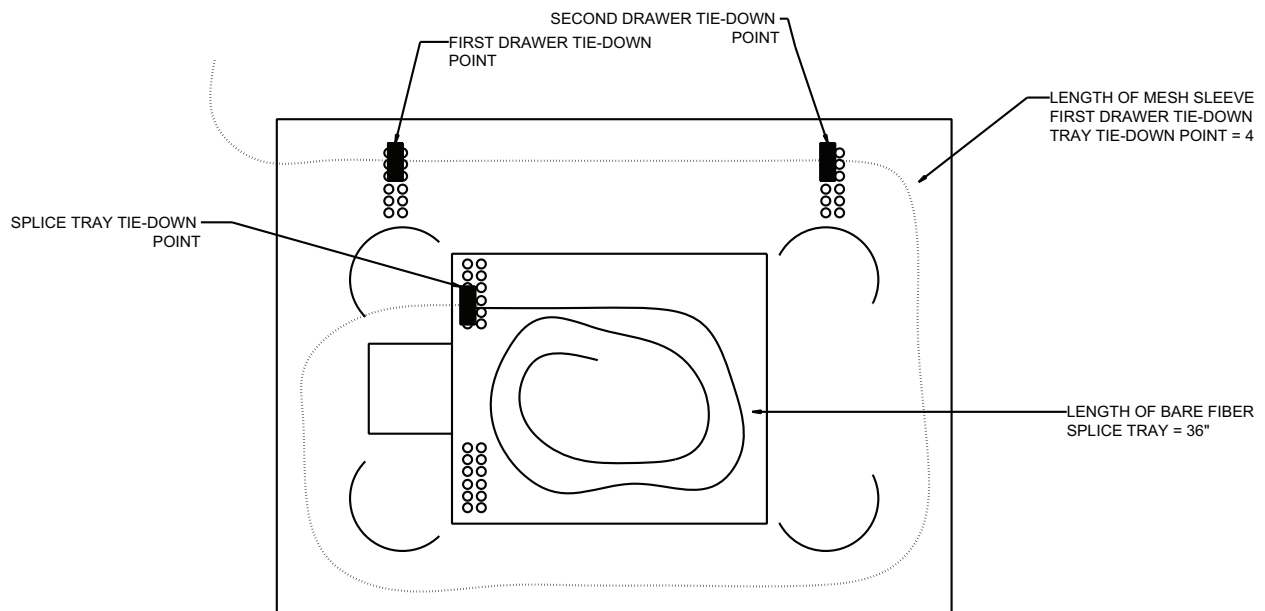

Figure 13. Example of Stacked Cable Clamps

7 ROUTING FIBERS IN SPLICE DRAWERS

For fiber routing within a splice drawer, four options are possible depending on whether splice trays are placed in splice drawers with splice tray opening on left or right side whether the cable enters the splice tray on left or right. Refer to [Figure 14](#), [Figure 15](#), [Figure 16](#), and [Figure 17](#).



SPLICE DRAWER BREAKOUT DIMENSIONS:
CABLE ENTRY LEFT + SPLICE TRAY ENTRY LEFT

27166-A

Figure 14. Cable Entry Left, Splice Tray Entry Left

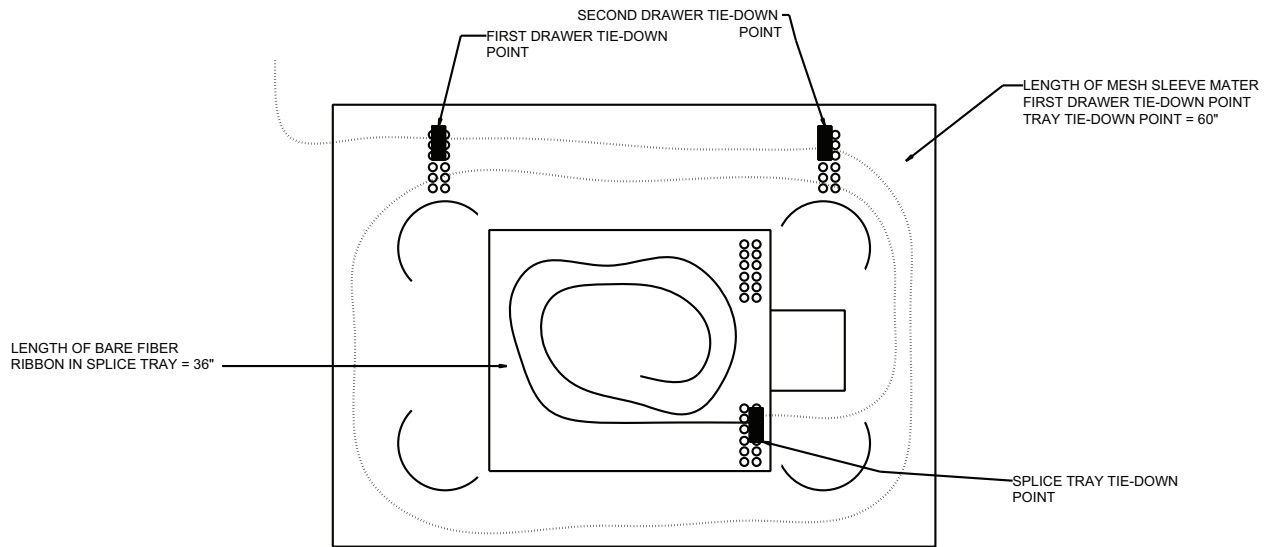

SPLICE DRAWER BREAKOUT DIMENSIONS:
CABLE ENTRY LEFT + SPLICE TRAY ENTRY RIGHT

27169-A

Figure 15. Cable Entry Left, Splice Tray Entry Right

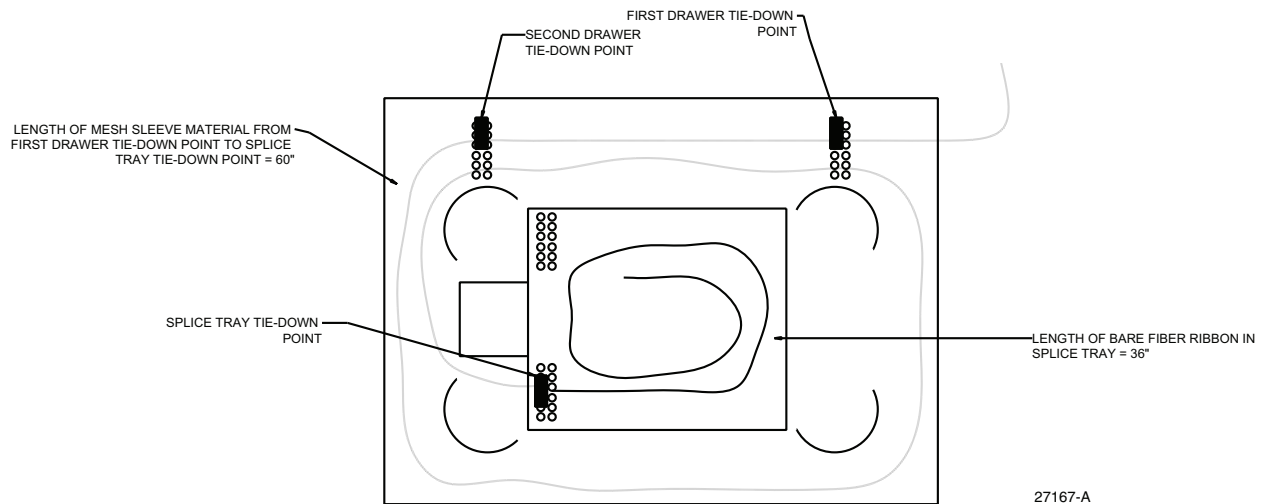

SPLICE DRAWER BREAKOUT DIMENSIONS:
CABLE ENTRY RIGHT + SPLICE TRAY ENTRY LEFT

27167-A

Figure 16. Cable Entry Right, Splice Tray Entry Left

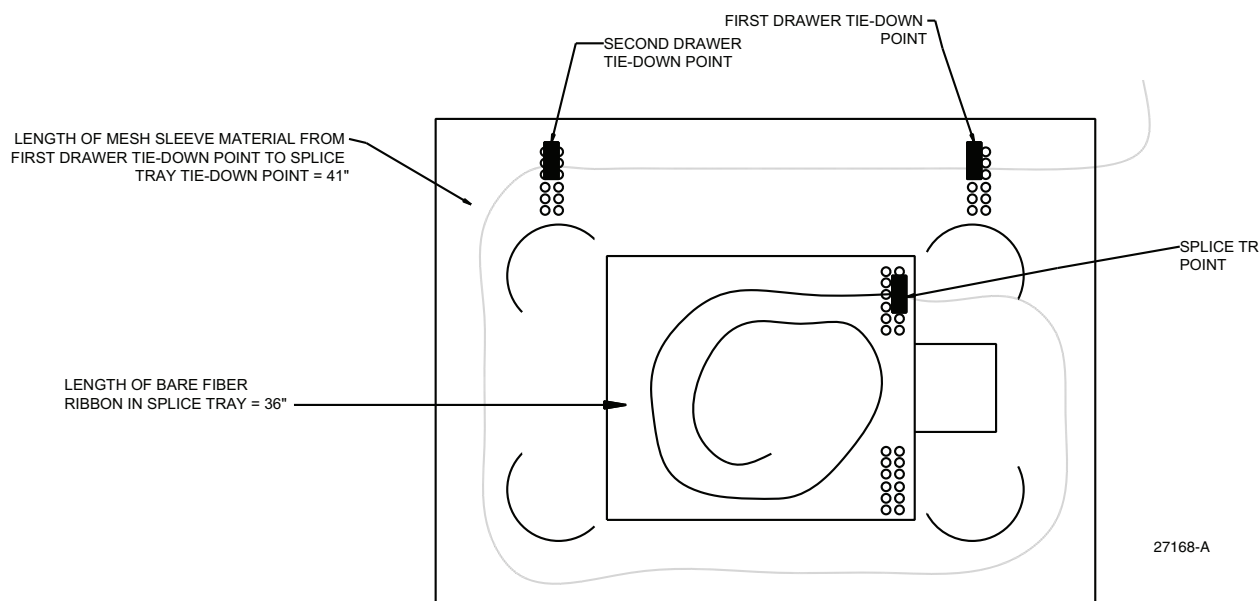

**SPLICE DRAWER BREAKOUT DIMENSIONS:
CABLE ENTRY RIGHT + SPLICE TRAY ENTRY RIGHT**

Figure 17. Cable Entry Right, Splice Tray Entry Right

The FEC can be loaded with different types of splice trays, listed in [Table 4](#).

Table 4: Splice Trays Used With FEC

CATALOG NUMBER (MID IF ANY)	TRAY TYPE	SPLICE SLEEVE PROTECTOR	SPLICE TRAY TYPE	DIMENSIONS
FST-HS	Single Tray (12-fiber)	FST-ACC001	Heat shrink (single fiber fusion)	0.3" x 11.75" x 5" (9 mm x 299 mm x 127 mm)
FST-D-HS	Dual Tray (24-fiber)	FST-ACC001	Heat shrink (single fiber fusion)	0.5" x 11.75" x 5" (14 mm x 299 mm x 127 mm)
FST-HS-48	Dual Tray (48-fiber)	FST-ACC001	Heat shrink (single fiber fusion)	0.3" x 11.75" x 5" (9 mm x 299 mm x 127 mm)
FST-MT	Single Tray (12-fiber)	FST-ACC006	Mass fusion ribbon	0.5" x 11.75" x 5" (14 mm x 299 mm x 127 mm)
FST-D-MT	Dual Tray (24-fiber)	FST-ACC006	Mass fusion ribbon	0.5" x 11.75" x 5" (9 mm x 299 mm x 127 mm)

Table 4: Splice Trays Used With FEC, continued

CATALOG NUMBER (MID IF ANY)	TRAY TYPE	SPLICE SLEEVE PROTECTOR	SPLICE TRAY TYPE	DIMENSIONS
FST-XD-MT	Dual Tray (288-fiber Flat or Rollable)	757849-000 (SMOUV-1120-R2/12-02)	Mass fusion ribbon	0.95" x 11.75" x 5" (24.13 mm x 299 mm x 127 mm)
FST-HD-RR	Dual Tray (432-fiber Rollable)	757849-000 (SMOUV-1120-R2/12-02)	Mass fusion ribbon	0.95" x 11.75" x 5" (24.13 mm x 299 mm x 127 mm)

Use the following procedure to load splice trays and set up for splicing.

1. Determine the type of splice tray to be used per [Table 4](#).
2. Determine whether the splice trays will be placed in the splice drawers with the splice tray opening on the left or right side (usually decided based on local practice.) [Figure 18](#) shows an FST-XD-MT splice tray placed on a table with opening on the right side.
3. Open the splice drawer

Note: The splice drawer is assumed to be already loaded with correctly routed and tied down fibers as directed.

4. Follow the directions provided with the splice tray to route the fibers within the splice tray.
5. Splice per local practice.
6. Place the splice tray in the splice drawer
7. Close the splice drawer.
8. Continue loading any additional splice drawers with splice trays.

Figure 18 shows a FST-HD-RR splice tray, which has six splice chips. Figure 19 shows the FST-XD-MT splice tray, which has four splice chips and is set up here for splicing 288 fibers.



Figure 18. FST-HD-RR Splice Tray



Figure 19. FST-XD-MT Splice Tray With 288 Fibers

8 OPERATION

Operation consists of opening and closing the door. The doors are secured with over-center draw latches. To release the latch, pull out from the cabinet. To secure the latch, push the latch forward over-center to catch the tab on the cabinet, then draw back and press in on latch to secure the door.

9 CONTACT INFORMATION

- To find out more about CommScope® products, visit us on the web at www.commscope.com
- For technical assistance, customer service, or to report any missing/damaged parts, visit us at <http://www.commscope.com/SupportCenter>