

4

3

2



1

NOTES:

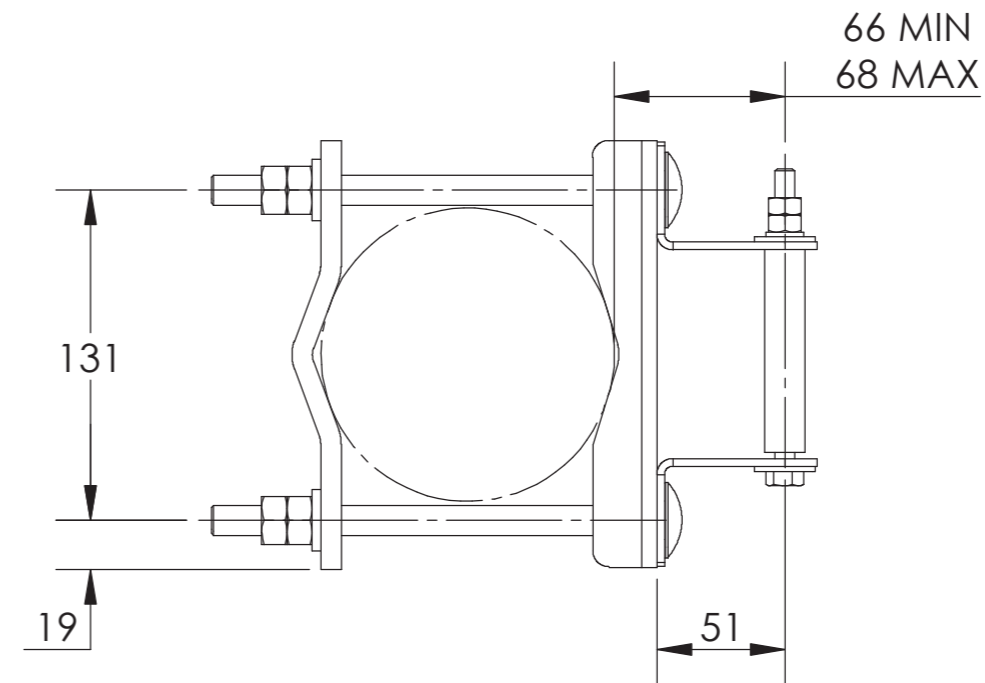
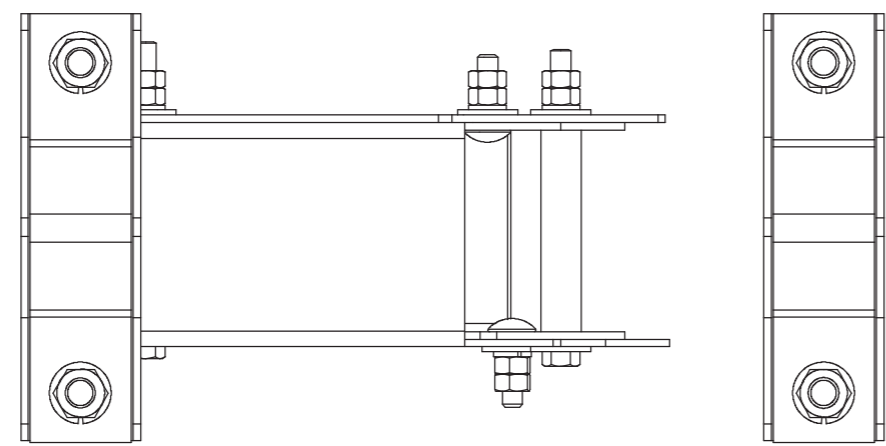
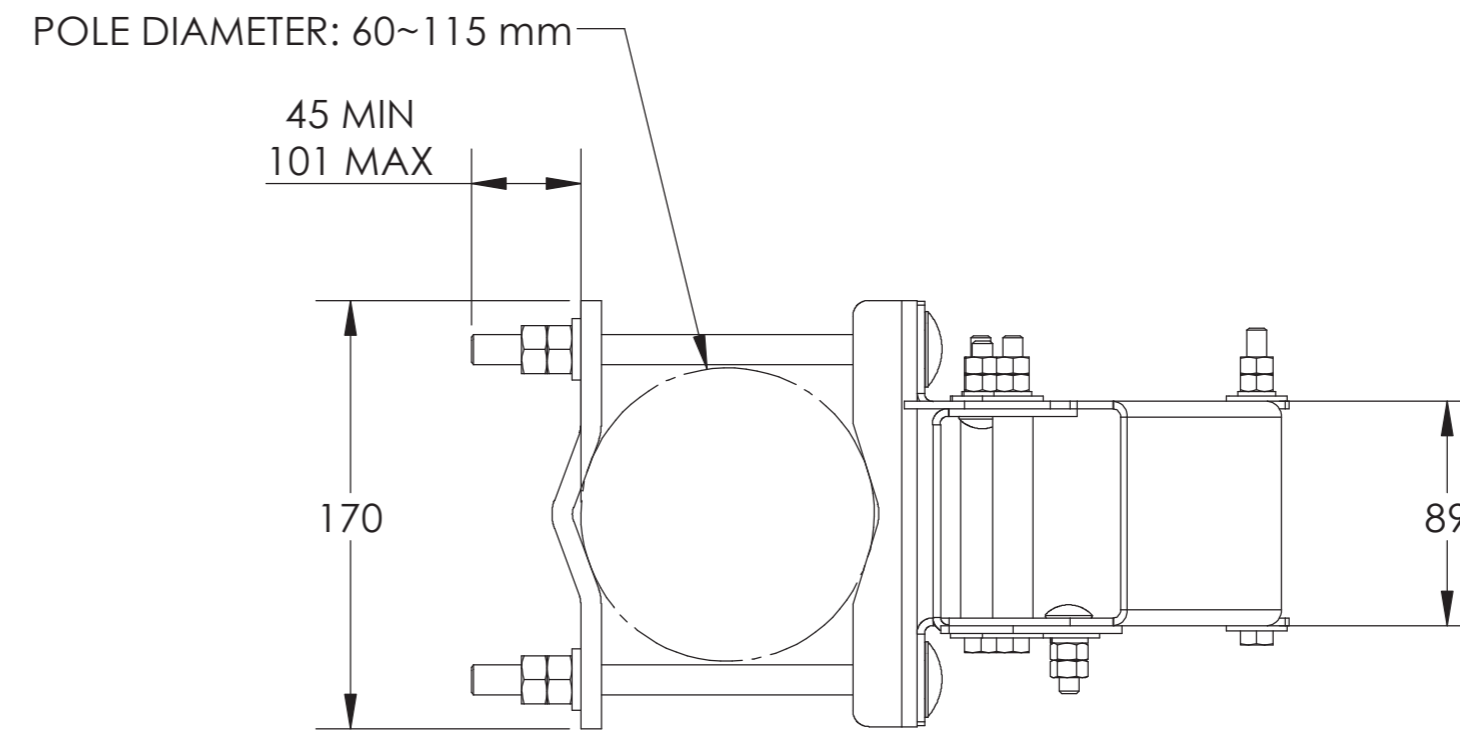
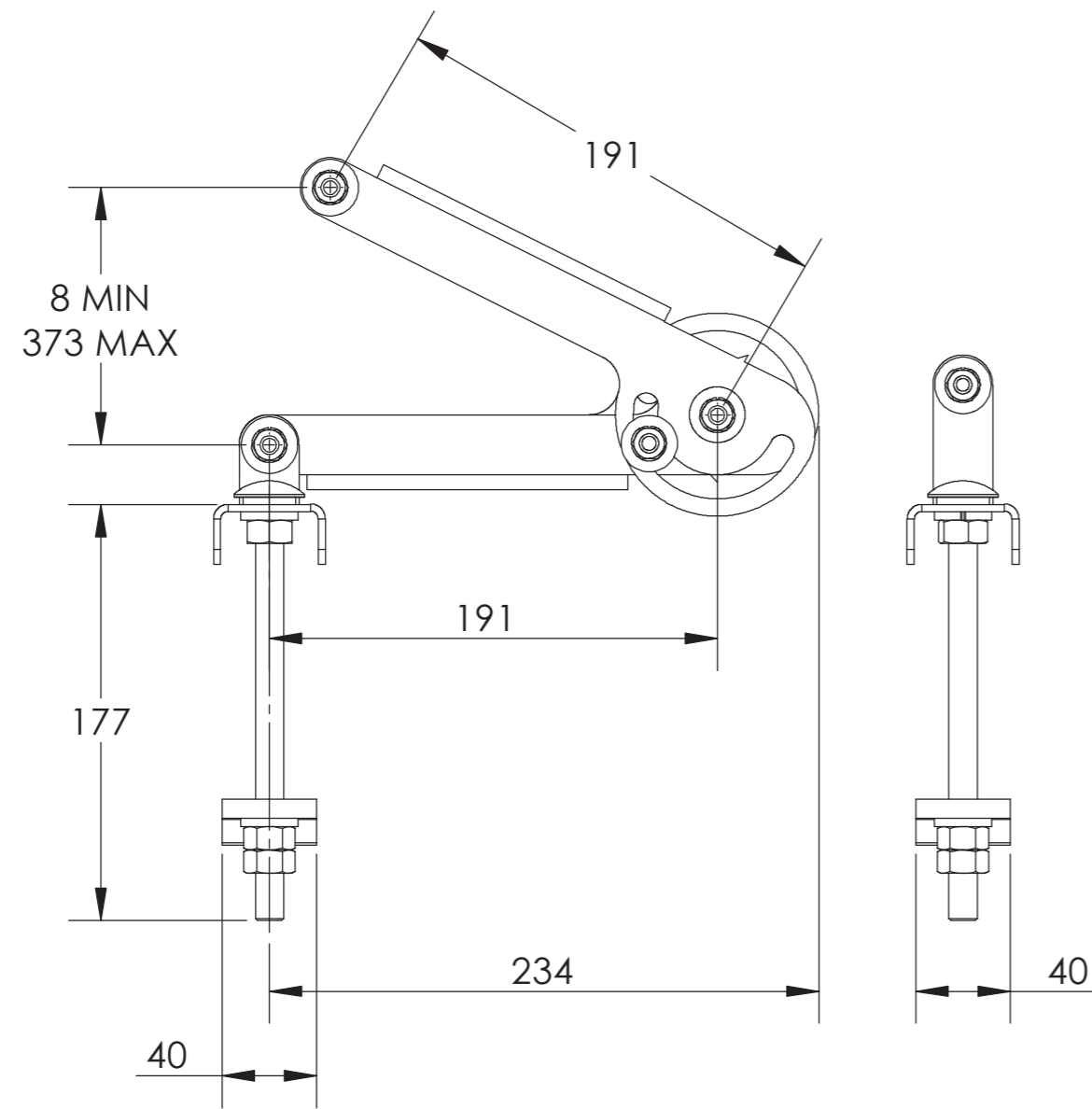
REVISIONS			
REV	DESCRIPTION	DATE	APPROVED
A	ECR 800003574: REL TO PRODUCTION PER EAO 601665	31JUL14 JJH	MB XA
C	ECR 8000010306: ADD DIMENSIONS.	10OCT15 QF	S.LIU/JIHE



600899A-2

MATERIAL N/A	DENSITY: N/A	UNLESS OTHERWISE SPECIFIED DIMENSIONS ARE IN MILLIMETERS INTERPRET PER ISO STANDARDS HANDBOOK TECHNICAL DRAWINGS VOLUMES 1 & 2, THIRD EDITION (2002)	 WESTCHESTER, IL. 60154 U.S.A.						
	MASS: 4.20 kg								
FINISH N/A	TOLERANCES		THIRD ANGLE PROJECTION						
	0 PLACE X ±								
	1 PLACE .X ±								
	2 PLACE .XX ±		DRAWN BY JJH 31JUL14	SIZE A2	CAGE CODE 84147				
ANGLES ±		ECN 8000010306-O	DOCUMENT NO. 600899A-2-L						
ALL SURFACES ✓		AUTH. GROUP 23	MODEL	DRAWING					
NOTICE: These drawings and specifications are the proprietary property of ANDREW CORPORATION and may be used only for the specific purpose authorized in writing by Andrew.			VERSION 01	STATUS RE	REVISION B	VERSION 02	STATUS RE	REVISION C	SHEET 1 OF 1

4

3

2

1