

REVISIONS			
REV.	DESCRIPTION	DATE	APPROVED
A	ECR 8000010073: REL TO PRODUCTION.	06SEP15 HWW	S.LIU/JIHE
B	ECR 8000034636: ADD DIM AND SHEET 2.	28MAR19 CMY	S.LIU/HANSEN.W

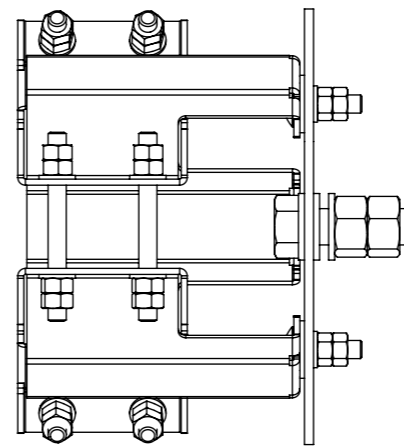
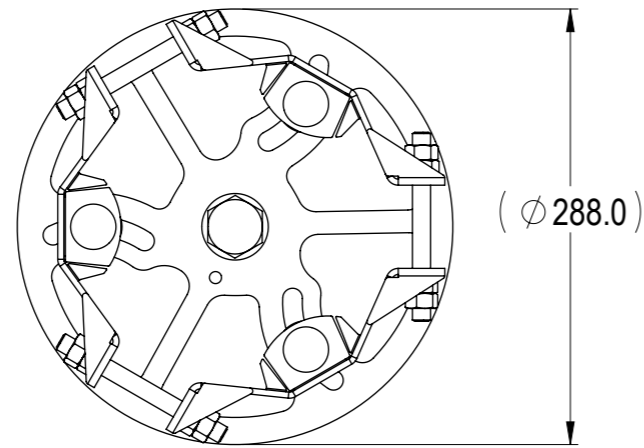
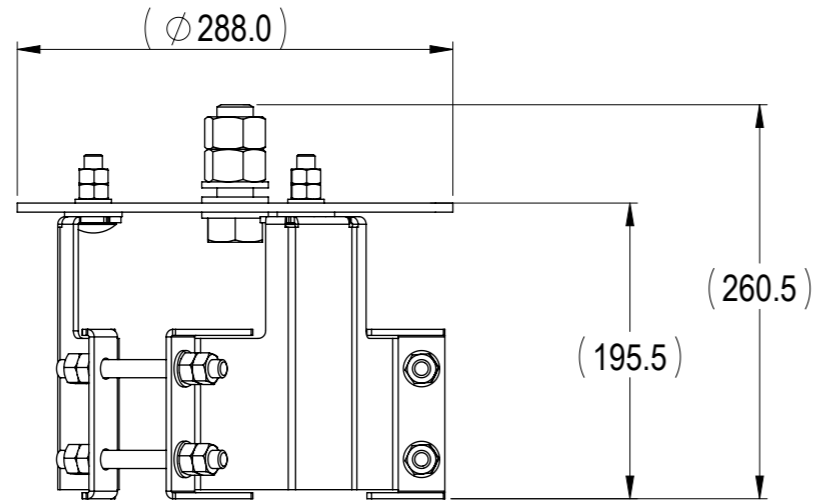

MC-MNT-TOP-2  
SCALE 1 : 5

COMMSCOPE, INC. OF NORTH CAROLINA

TOLERANCES		SAP MATERIAL MASTER
0 PLACE X ±	2 PLACE .XX ±	
1 PLACE .X ±	ANGLES ±	

FINISH N/A	MATERIAL N/A
---------------	-----------------

UNLESS OTHERWISE SPECIFIED DIMENSIONS ARE IN MILLIMETERS INTERPRET PER ISO STANDARDS HANDBOOK, TECHNICAL DRAWINGS, VOLUMES 1 & 2, THIRD EDITION (2002)	NAME	DATE	TITLE	
	CE HWW	06/09/2015	PRODUCT DRAWING	
	RW MC1105	03/28/2019		
	RV CHALIU	03/31/2019		
	AD HW8003	04/01/2019		
	RE ZHHCHEN	04/01/2019		
ECN 8000034636-O				
SCALE	DOCUMENT NO.	MC-MNT-TOP-2-L		
1:1				

DENSITY	g/mm <sup>3</sup>
MASS	grams
VOLUME	mm <sup>3</sup>
SURFACE AREA	mm <sup>2</sup>
HEIGHT	
LENGTH	
WIDTH	

SIZE	WORK AREA	23	MODEL			DRAWING			SHEET
A3			VERSION	STATUS	REVISION	VERSION	STATUS	REVISION	1 OF 2
			01	RE	B	01	RE	B	

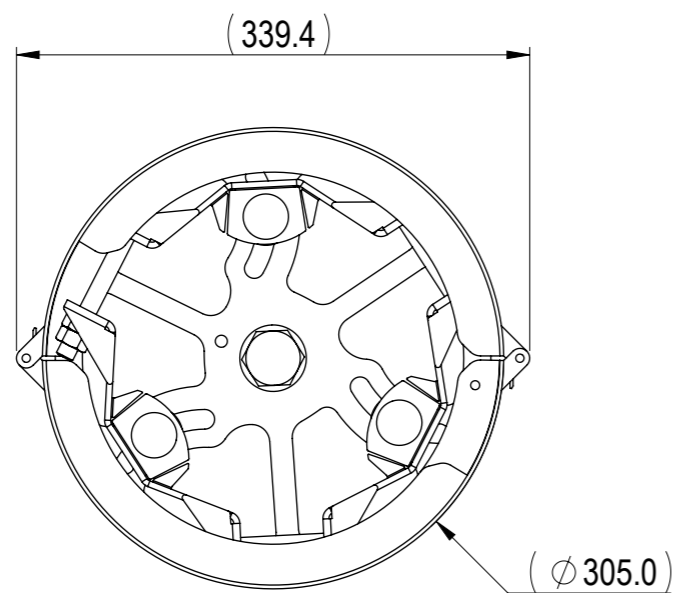
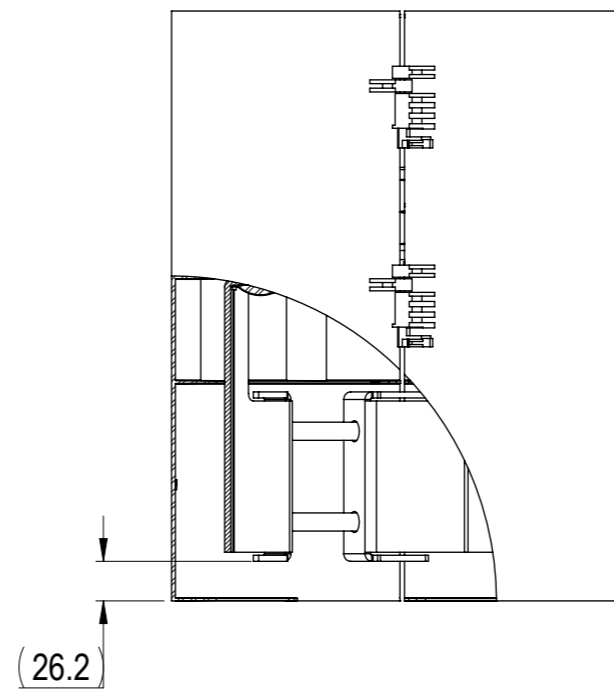
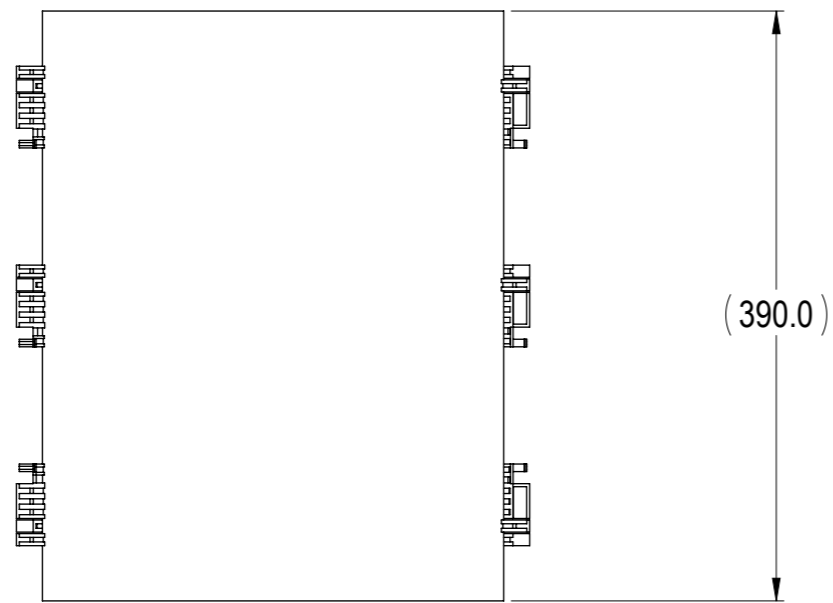

MC-MNT-TOP-2  
WITH SHROUD COVER  
SCALE 1 : 5

COMMSCOPE, INC. OF NORTH CAROLINA				
TITLE PRODUCT DRAWING				
SIZE <b>A3</b>	SCALE <b>1:5</b>	DOCUMENT NO. <b>MC-MNT-TOP-2-L</b>		
	DRAWING			SHEET 2 OF 2
	VERSION 01	STATUS RE	REVISION B	