

MT-216-NS

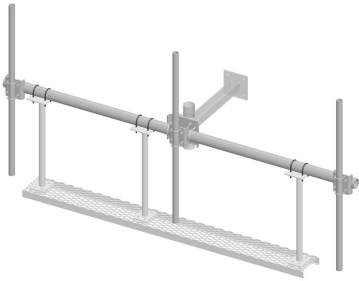

Cellular Pipe Frame, 12 ft face

Product Classification

Product Type Pipe mount

General Specifications

Mounting Pipe, 114.3 mm (4-1/2 in) OD

Dimensions

Height 254 mm | 10 in

Face Width 3.81 m | 12.5 ft

Width 3810 mm | 150 in

Length 88.9 mm | 3.5 in

MT-216-NS

Outline Drawing

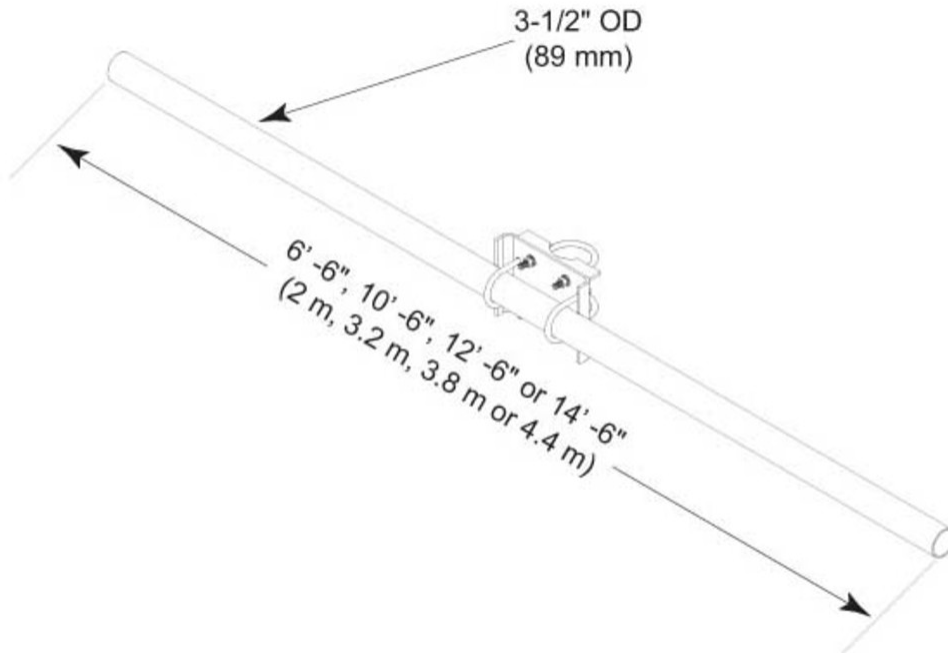

Material Specifications

Material Type Hot dip galvanized steel

Mechanical Specifications

Wind Rating 120 mph (BWS) at 150 ft AGL | 140 mph (3-second gust) at 150 ft AGL using Exposure D per FBC

Wind Rating Criteria Four 72 in x 8 in panel antennas per sector

Wind Rating Test Method TIA/EIA-222

Environmental Specifications

EPA with 1/2 in (12 mm) radial ice 1.347 m² | 14.5 ft²

EPA without ice 1.059 m² | 11.4 ft²

Packaging and Weights

MT-216-NS

Included	Cellular pipe frames
Packaging quantity	1
Weight, net	66.3 kg 146.166 lb

Regulatory Compliance/Certifications

Agency	Classification
ISO 9001:2015	Designed, manufactured and/or distributed under this quality management system

* Footnotes

Wind Rating	BWS—Base Wind Speed; FBC—Florida Building Code
EPA with 1/2 in (12 mm) radial ice	EPA—Effective Projected Area
EPA without ice	EPA—Effective Projected Area