

MT-F1607

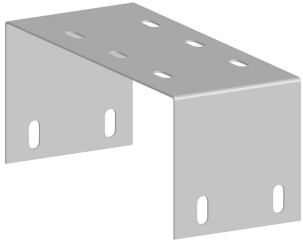

Splice for Wall Kit, for four coaxial cable runs

Product Classification

Product Type Splice kit

General Specifications

Cable Runs, quantity 4

Mounting Wall coaxial cable support kits

Dimensions

Height 127 mm | 5 in

Width 127 mm | 5 in

Length 304.8 mm | 12 in

MT-F1607

Outline Drawing

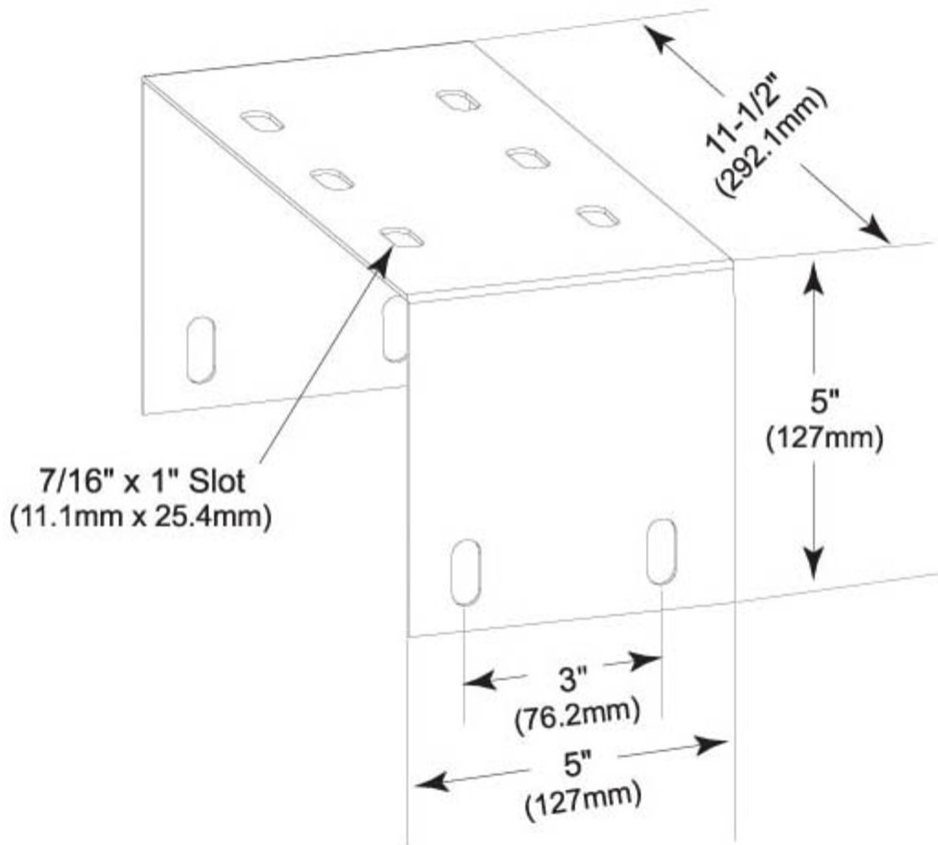

Material Specifications

Material Type Galvanized steel

Mechanical Specifications

Wind Rating For Specifications, please contact steelproducts@commscope.com or call 800-255-1479

Packaging and Weights

Included Hardware | Splices

Packaging quantity 1

Weight, net 1.1 kg | 2.425 lb

MT-F1607

Regulatory Compliance/Certifications

Agency

ISO 9001:2015

Classification

Designed, manufactured and/or distributed under this quality management system

* Footnotes

Wind Rating

BWS—Base Wind Speed; FBC—Florida Building Code