

# TP-100

---

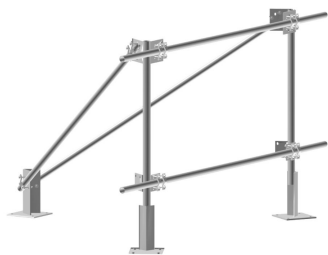

## Rooftop Mount

### Product Classification

**Product Type** Rooftop mount

### General Specifications

**Mounting** Penetrating

### Dimensions

**Height** 1905 mm | 75 in

**Face Width** 3.353 m | 11 ft

**Width** 3,352.8 mm | 132 in

**Length** 2.896 m | 9.5 ft

**Pipe Outer Diameter** 60.96 mm | 2.4 in | 73.66 mm | 2.9 in

# TP-100

## Outline Drawing

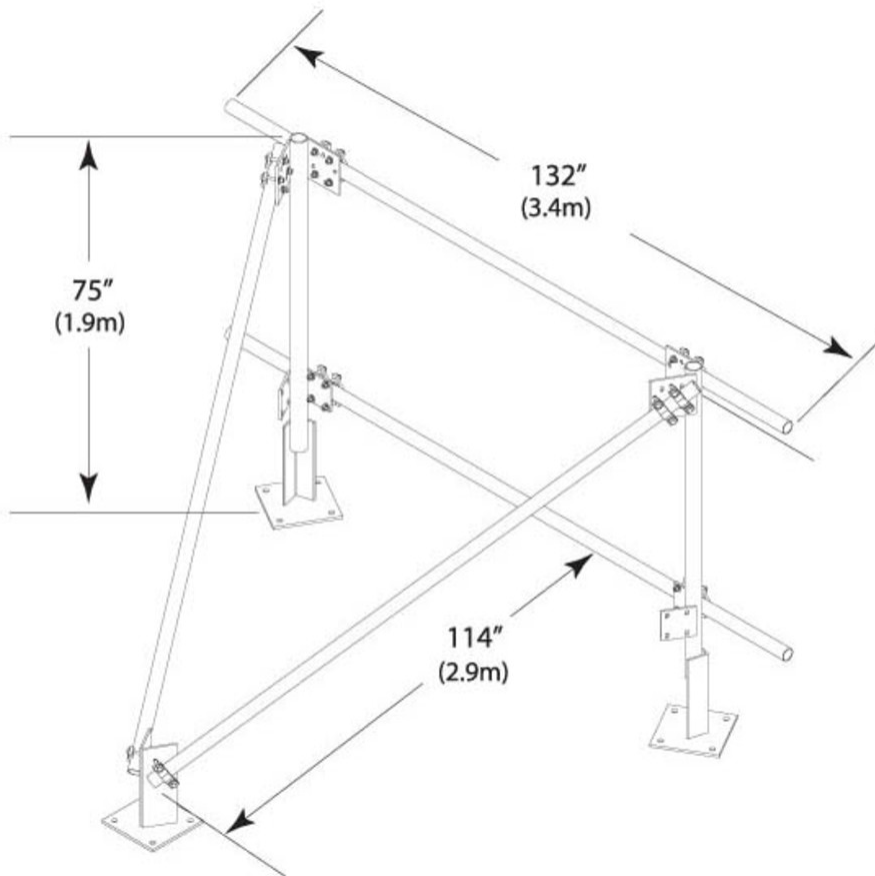

## Material Specifications

**Material Type** Hot dip galvanized steel

## Mechanical Specifications

**Wind Rating** For Specifications, please contact [steelproducts@commscope.com](mailto:steelproducts@commscope.com) or call 800-255-1479

## Packaging and Weights

**Included** Mount

**Packaging quantity** 1

**Weight, net** 173.7 kg | 382.942 lb

## Regulatory Compliance/Certifications

# TP-100

---

**Agency**

ISO 9001:2015

**Classification**

Designed, manufactured and/or distributed under this quality management system

**\* Footnotes****Wind Rating**

BWS—Base Wind Speed; FBC—Florida Building Code