

# APG-BNFNF-350

---



Arrestor Plus® Gas Tube Surge Arrester (350 V), 45–2170 MHz, with interface types N Female Bulkhead and N Female

## Product Classification

<b>Product Type</b>	Surge arrester
<b>Ordering Note</b>	CommScope® standard product in Asia Pacific

## General Specifications

<b>Device Type</b>	dc Pass
<b>Body Style</b>	Bulkhead
<b>Inner Contact Plating</b>	Gold
<b>Interface</b>	N Female Bulkhead
<b>Interface 2</b>	N Female
<b>Outer Contact Plating</b>	Silver
<b>Pressurizable</b>	No

## Dimensions

<b>Height</b>	30.99 mm   1.22 in
<b>Width</b>	30.99 mm   1.22 in
<b>Length</b>	68.07 mm   2.68 in

## Outline Drawing

# APG-BNFNF-350

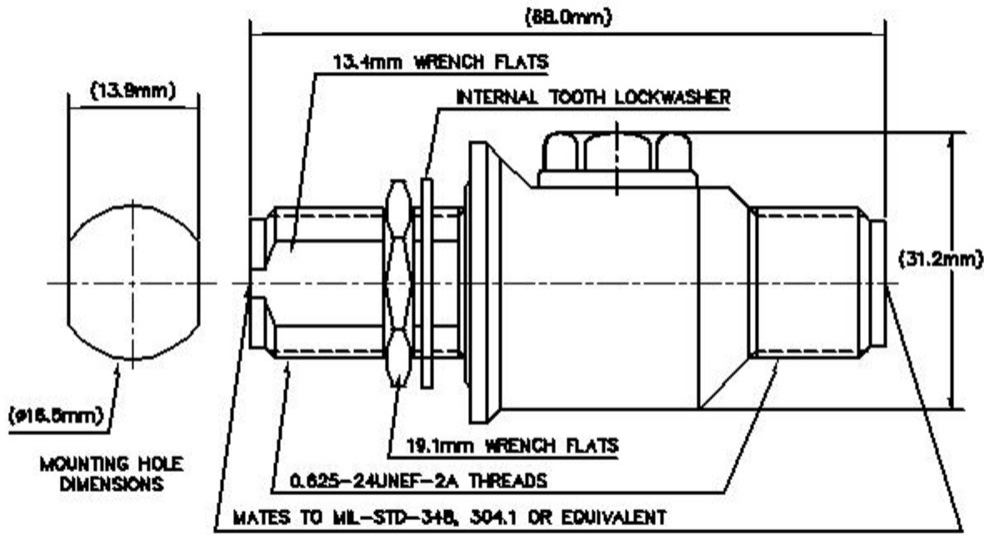

## Electrical Specifications

<b>Insertion Loss, typical</b>	0.1 dB
<b>Average Power</b>	400 W
<b>Connector Impedance</b>	50 ohm
<b>Gas Tube Voltage</b>	350 V
<b>Lightning Surge Current</b>	20 kA
<b>Lightning Surge Current Waveform</b>	8/20 waveform
<b>Operating Frequency Band</b>	1000 – 2000 MHz   2000 – 2170 MHz   45 – 1000 MHz

## VSWR/Return Loss

Frequency Band	VSWR	Return Loss (dB)
45–1000 MHz	1.106	25.96
1000–2000 MHz	1.173	21.98
2000–2170 MHz	1.33	17

## Mechanical Specifications

<b>Attachment Durability</b>	25 cycles
<b>Interface Durability</b>	500 cycles
<b>Interface Durability Method</b>	IEC 61169-16:9.5
<b>Mechanical Shock Test Method</b>	MIL-STD-202F, Method 213B, Test Condition C

# APG-BNFNF-350

---

## Environmental Specifications

<b>Operating Temperature</b>	-40 °C to +100 °C (-40 °F to +212 °F)
<b>Storage Temperature</b>	-40 °C to +100 °C (-40 °F to +212 °F)
<b>Attenuation, Ambient Temperature</b>	20 °C   68 °F
<b>Average Power, Ambient Temperature</b>	40 °C   104 °F
<b>Corrosion Test Method</b>	MIL-STD-202, Method 101, Test Condition B
<b>Immersion Depth</b>	1 m
<b>Immersion Test Mating</b>	Mated
<b>Immersion Test Method</b>	IEC 60529:2001, IP68
<b>Moisture Resistance Test Method</b>	MIL-STD-202, Method 106
<b>Thermal Shock Test Method</b>	MIL-STD-202, Method 107, Test Condition A-1, Low Temperature -55 °C
<b>Vibration Test Method</b>	GR 2846-CORE
<b>Water Jetting Test Mating</b>	Mated
<b>Water Jetting Test Method</b>	IEC 60529:2001, IP66

## Packaging and Weights

<b>Weight, net</b>	0.141 kg   0.31 lb
--------------------	--------------------

## Regulatory Compliance/Certifications

<b>Agency</b>	<b>Classification</b>
CHINA-ROHS	Below maximum concentration value
ISO 9001:2015	Designed, manufactured and/or distributed under this quality management system
REACH-SVHC	Compliant as per SVHC revision on <a href="http://www.commscope.com/ProductCompliance">www.commscope.com/ProductCompliance</a>
ROHS	Compliant
UK-ROHS	Compliant



## \* Footnotes

<b>Insertion Loss, typical</b>	0.05√freq (GHz) (not applicable for elliptical waveguide)
<b>Immersion Depth</b>	Immersion at specified depth for 24 hours