

PowerShift® Verizon Installation instructions

Controller Software Version: 4.8.42 & 4.8.43

The patent PowerShift system is designed to optimize electrical draw by adjusting voltage dynamically to match your exact RRU power requirements up to 650 feet using 6AWG Power Cable trunks.

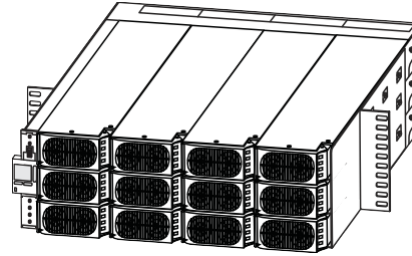

Section 1: PowerShift System Components / General Specifications 02

Section 2: Installation Check List 04

Section 3: General Wiring Diagram..... 05

Section 4: Configuration - Tower, Rooftop / Boost module Population Options..... 06

Section 5: RS485 Serial Connections / Input Power from DC Power Plant 07

Section 6: Redundant Boost module Population Options..... 08

Section 7: Power Cable Mapping 09

Section 8: Circuit Map Worksheet (Leave on-site)..... 10

Section 9: Rack Installation / Controller and RS485 Card Installation 10

Section 10: Wiring of the Rack / Lug Preparation / Wiring Sequence 12

Section 11: Power Up and Configuration Procedure..... 13

Section 12: Closeout Package 26

Section 13: Troubleshooting Raycap Issues 27

Section 14: PowerShift Alarms and Troubleshooting..... 29

Section 15: Alarm / GP / RS485 Connectors 33

Field Engineering Services (FES)

Support services, such as our Field Engineering Services (FES) Group gives CommScope customers access to technical support where and when it is needed the most — in the field. The FES team is staffed by an expert team of technicians who, in turn, are supported by some of the brightest and most experienced product line managers.

Customer Service Center

United States and Mexico 1-888-297-6433 (technical support) or 1-888-235-5732 (main number)
International: +1-779-435-8579

For the most current, up-to-date information on all our products and product information please visit our eCatalog section at www.commscope.com.

Section 1: PowerShift System Components

The PowerShift System Consists of the following components: One shelf, one controller card, one RS485 card, one or more pair of boost module and bypass module, and Raycap OVP equipment.

The PowerShift system is used in conjunction with the existing DC power plant at the installation site.

1. The shelf has capacity for twelve modules; 6 power boost modules and 6 bypass modules (the power and bypass modules are installed in pairs)
2. The modules are plug-and-play for easy installation and site maintenance.
3. Each module has DC input and DC output for two Remote Radio Units (RRU), for a total capacity of 12 RRU sectors per PowerShift shelf.
4. Each module unit is also provided with LED diagnostic indicators, explained in section 12.
5. The shelf adjusts voltage levels based on RS485 feedback from the Raycap equipment.

Rack Part Number:

PS-R-1600

Boost Module Part Number:

PS-1600-73 (white front grill)

Bypass Module Part Number:

PS-Bypass-1 (grey front grill)

Pulsar Edge Controller:

PULSAR-EDGE-CNTRL

RS485 Communications Card:

RS485-CARD

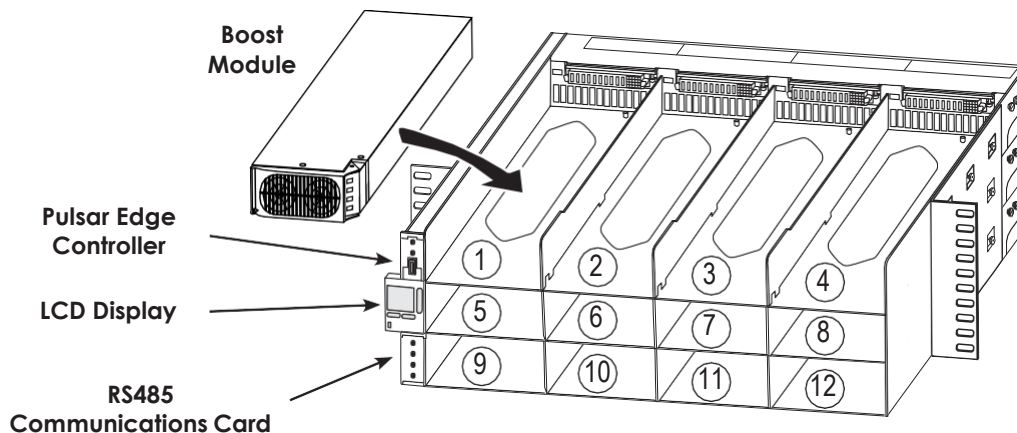

General Specifications (Boost and Bypass Module)

| Electrical ¹ | Typical | Range |
|---------------------------------------|--|--|
| Input Voltage ² | -54VDC | Cut-off: -38VDC Turn-on: -43VDC ³ Maximum: -58VDC |
| Input Current ² | 10A | 0-57 A @ -38 VDC |
| Efficiency | > 97% | > 93% |
| PS Output Voltage ² | -60 VDC | -48 to -73 VDC |
| PS Output Current ² | 15 A | 0-30 A (boost module) 0-40 A (bypass module) |
| Output Voltage Ripple | 400 mV rms | |
| Total Power output ⁴ | 2000 W (boost module) 1600 W (bypass module) | |
| Programmable RRU Voltage ⁵ | -53.5V +/- 3V | |
| Gauge Range | 0-6 AWG | |
| Length Range | 150-650 ft (using 6AWG power cable) ⁶ | |

- ¹ Per circuit; 2 circuits per module
- ² Input/output voltage and current range are guaranteed values, actual operating values will typically exceed these up to 10%
- ³ Turn-on voltage is higher than cut-off voltage in order to provide hysteresis protection
- ⁴ Total power = power consumed by radio + power loss in trunk cable
- ⁵ RRU input voltage set-point is factory programmed (not user settable). Other voltage set-point are possible, contact CommScope
- ⁶ 650ft of 6AWG ≈ 0.54 Ohms loop resistance. Longer cable lengths are possible, contact CommScope for more information

Section 2: Installation Check List

- Install OVP base and top hardware using appropriate Raycap OVP documentation (e.g. Install Instructions RCMDC-6627-PF-48)
- Set OVP configuration switch as appropriate for base and top hardware (multiple base units must have unique address ID)
- Important: Ensure OVP rackmount configuration switch is set prior to rack installation (the switch may be inaccessible after rack installation)
- Install PowerShift Shelf
- Install cable (power, fiber and twisted pair) from base up to the tower/roof top (e.g., using CommScope hybrid trunk cable)
- Install cables between OVP tower/roof top hardware and remote radio units (power, fiber)
- Install power cables between DC plant circuit breakers and PowerShift Shelf input terminals
- Install power cables between PowerShift Shelf output terminals and OVP base input terminals
- Install RS485 data cable between PowerShift Shelf and OVP base hardware
- If multiple OVP base units are installed, install RS485 data cables between them (daisy chain)
- Connect trunk cables to OVP base hardware and connect to OVP tower/roof top hardware (power, twisted-pair, fiber)
- Set hardware jumper on PowerShift Controller card and install card into PowerShift Shelf
- Install RS485 Protocol Converter card into PowerShift Shelf
- Complete all the steps in Section 11: Power Up and Configuration Procedure
- Confirm the site information and all radio circuit information has been entered in the GUI
- Confirm all the required files have been captured to your PC for inclusion in the installation closeout package
- Confirm there are no active alarms on the GUI or on the Raycap hardware
- Confirm the Circuit Map Worksheet is filled out and is left at the site
- If possible, bring the radios to full operational state (user traffic) and confirm proper operation

Section 3: General Wiring Diagram

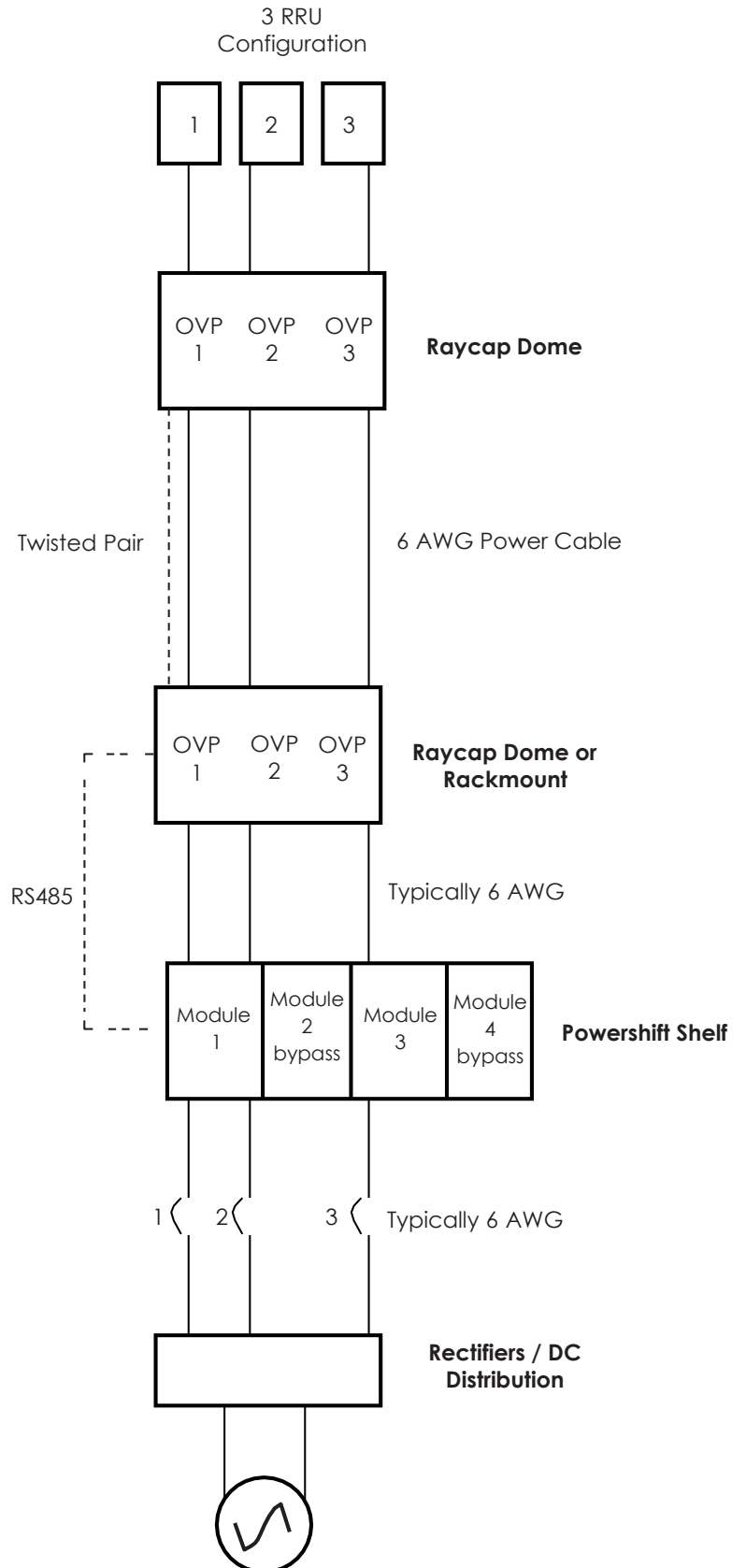
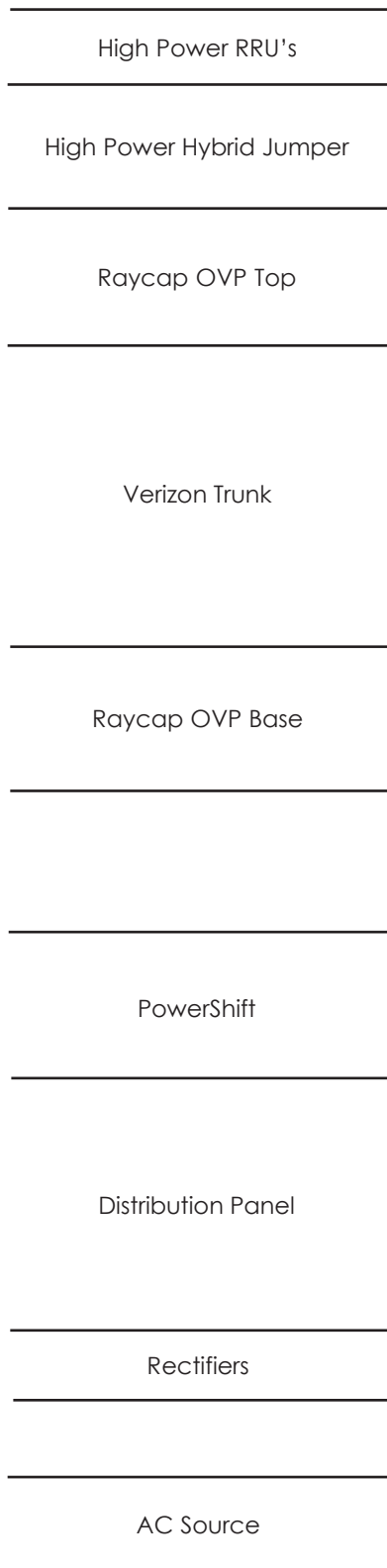

Section 4: Configurations

*Use standard Ethernet patch cable for RS485 connection

12 RRU Tower Top

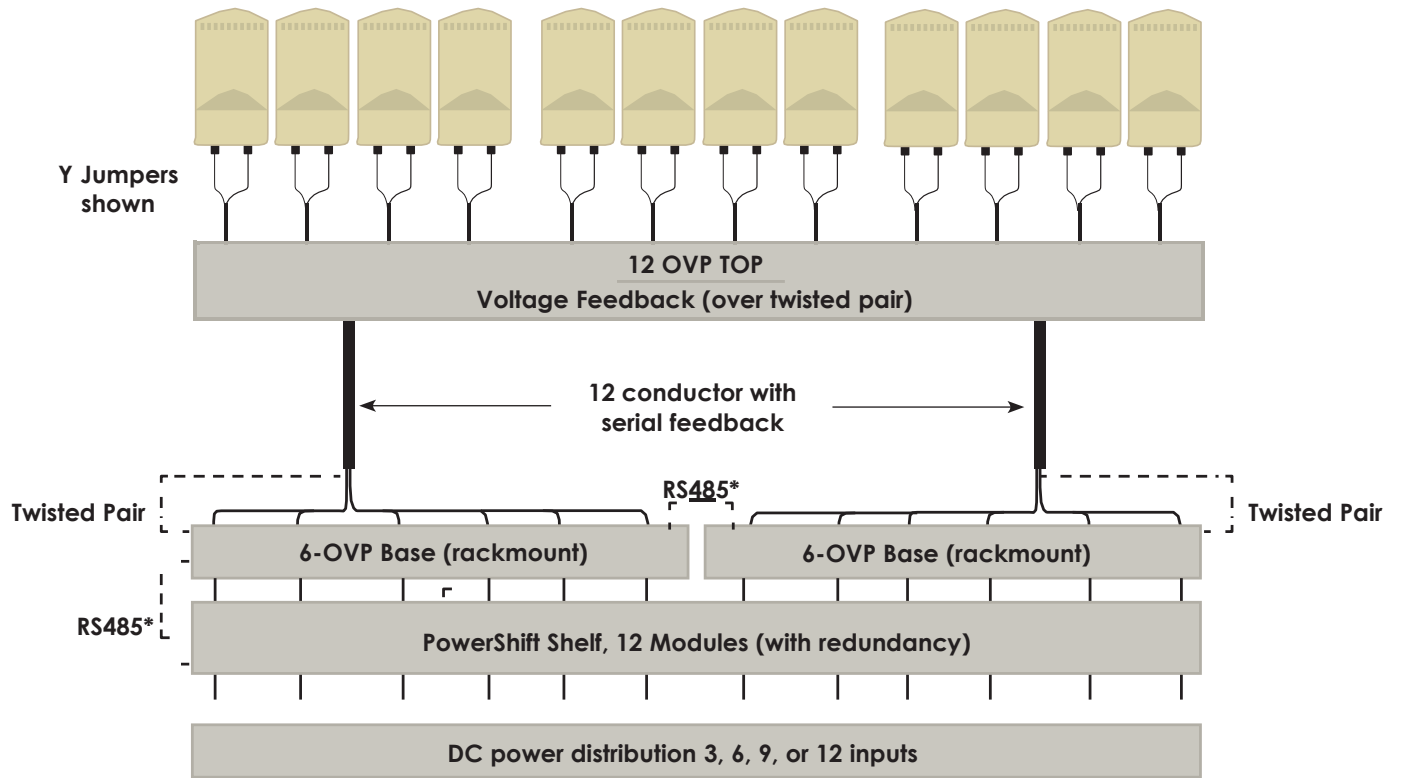

6 RRU Tower Top

*Use standard Ethernet patch cable for RS485 connection

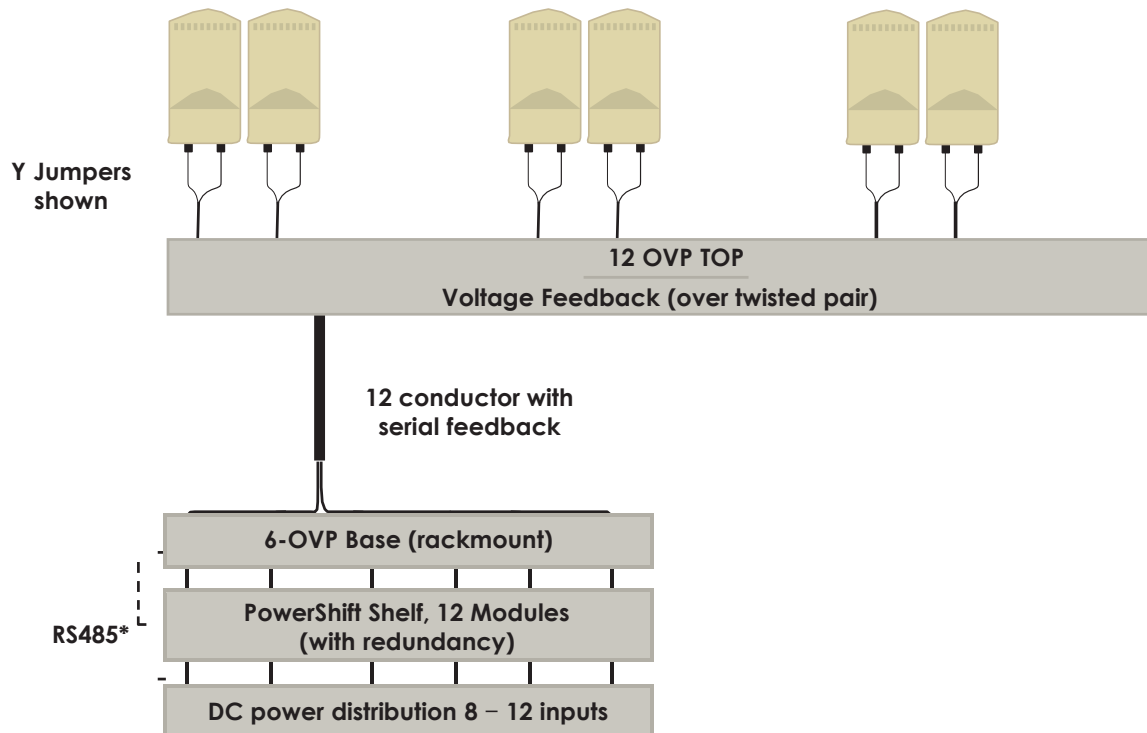

6 or 12 RRU Roof Top

*Use standard Ethernet patch cable for RS485 connection

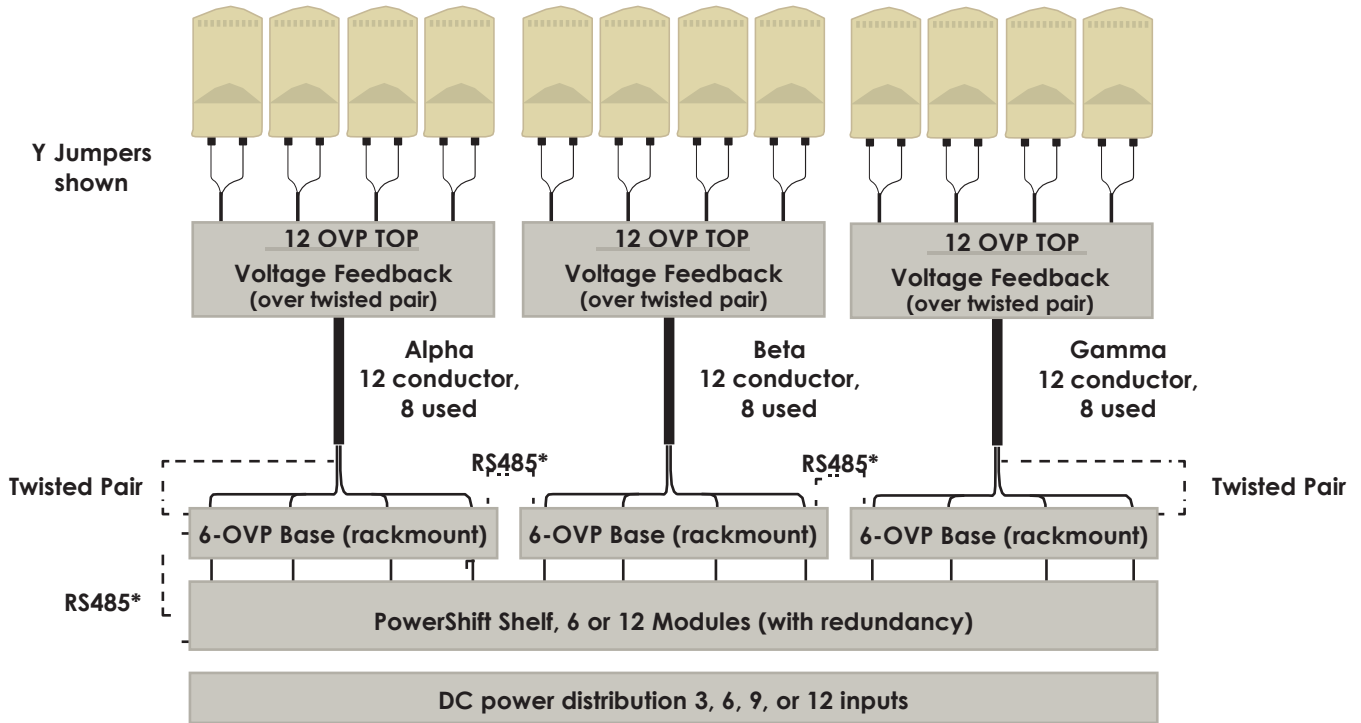

Section 5: RS485 Serial Connections / Input Power from DC Power Plant (Refer to Raycap for ID settings)

Tower Top

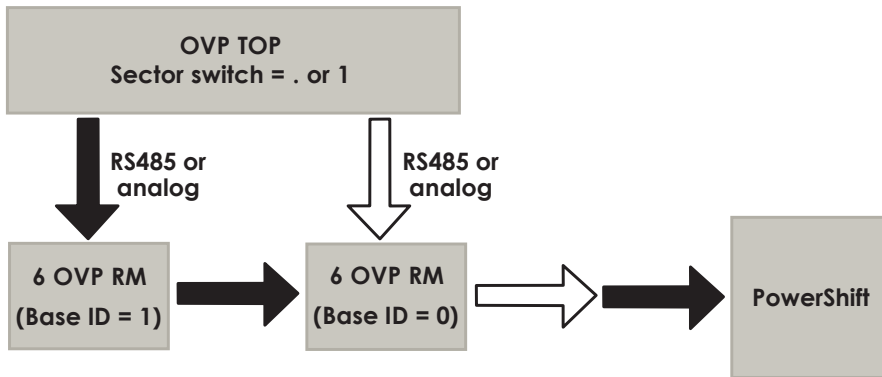

Roof Top

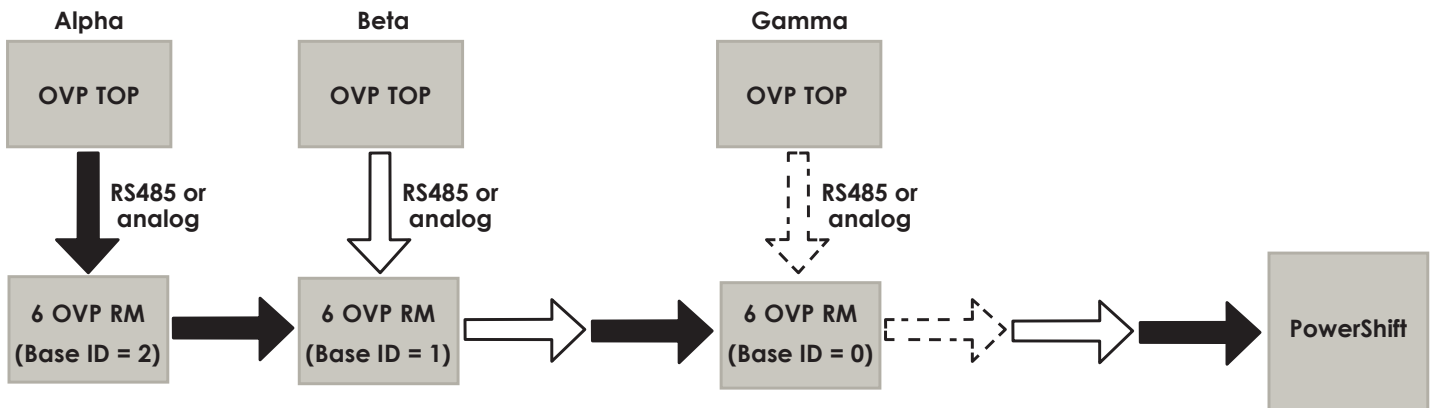

Section 6: Redundant Boost Module Population Options

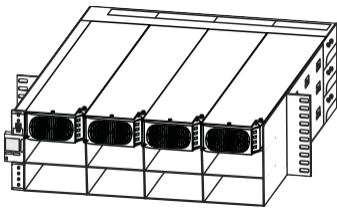

3 RRU

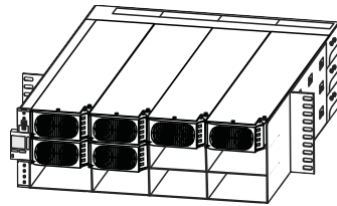

6 RRU

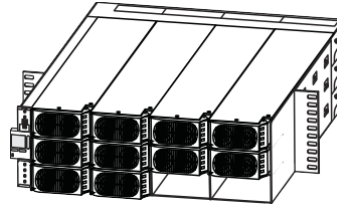

9 RRU

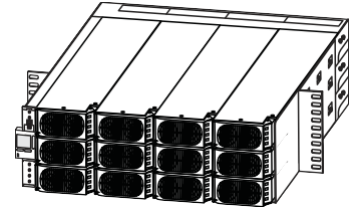

12 RRU

Boost modules are populated in the odd-number shelf slots and bypass modules are populated in the adjacent even-numbered slot. The bypass module provides redundant functionality in the event of a boost module failure. This example shows the module population for a 9 RRU solution.

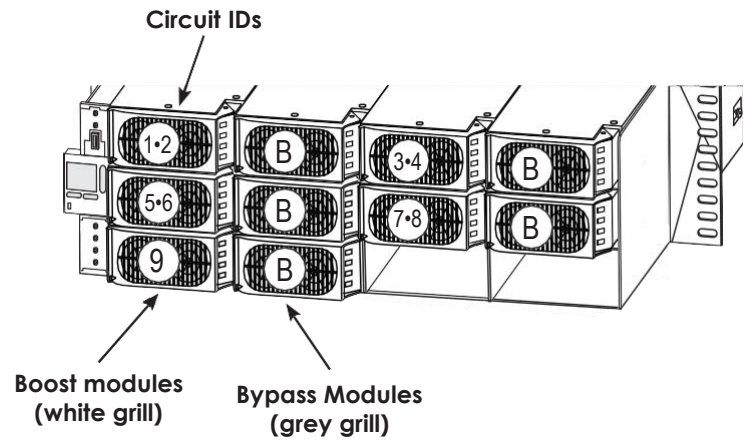

Redundant Power Function

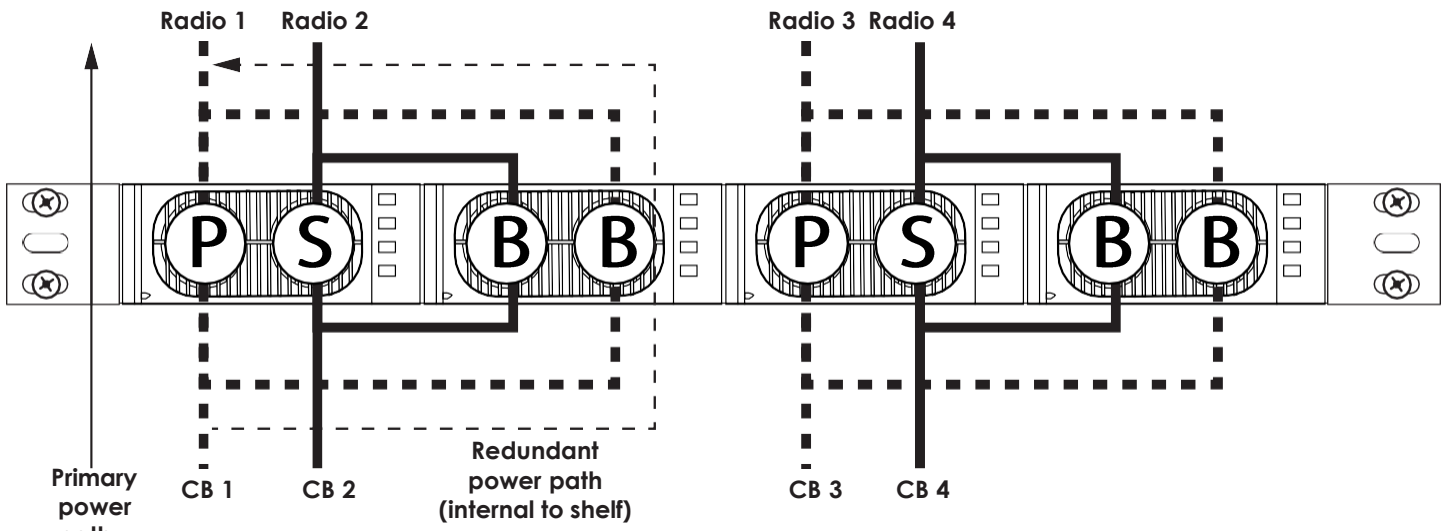

P = First Circuit
 S = Second Circuit
 B = Bypass
 CB = Circuit Breaker

Section 7: Power Cable Mapping

12 RRU Top Dome / 6 RRU Base Rackmount (x2)

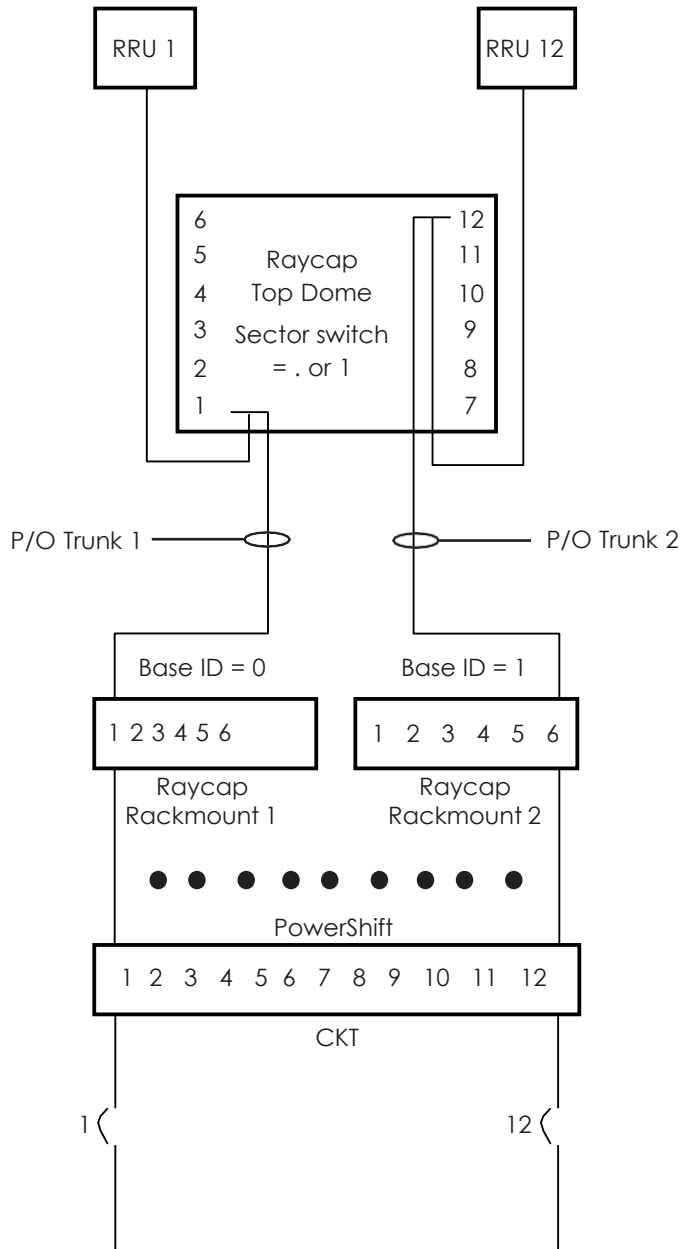

12 RRU Top Dome / 12 RRU Base Dome

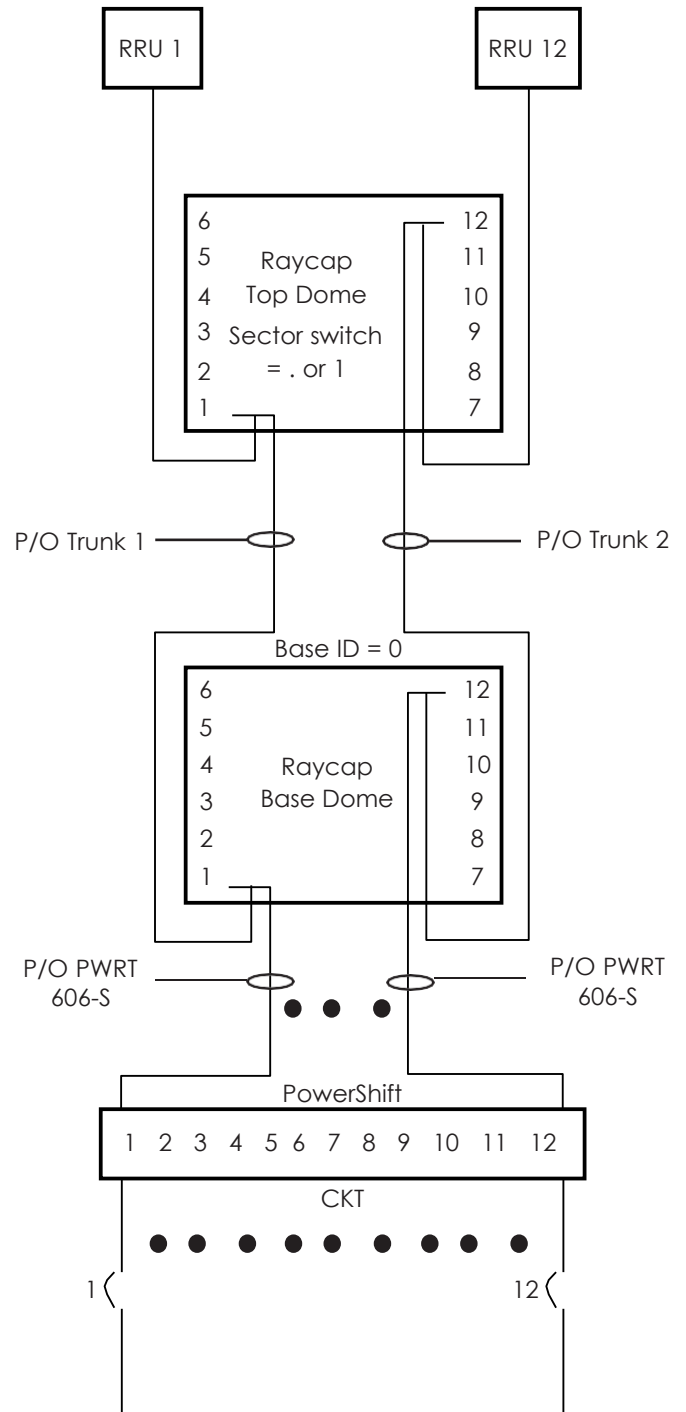

Section 8: Circuit Map Worksheet (leave on-site)

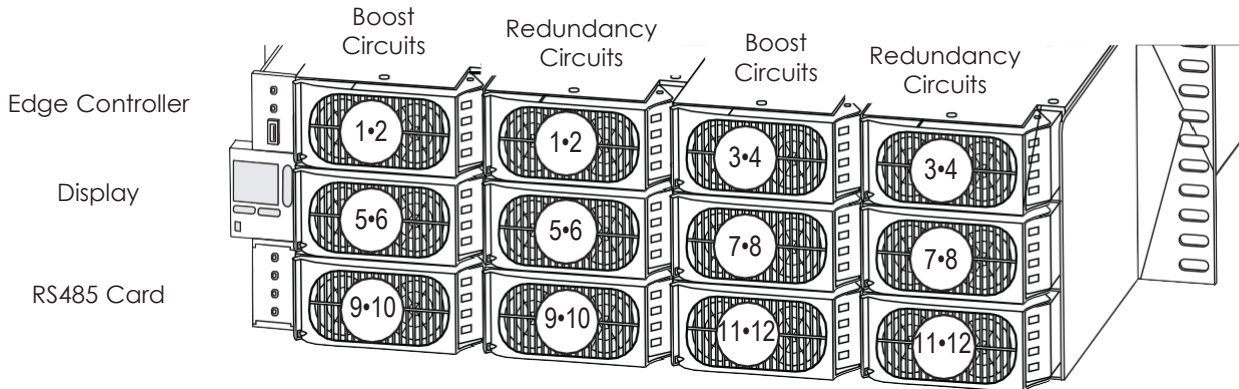

| PowerShift Circuit # | RRU # | RRU Sector | RRU Technology | Circuit Breaker # | OVP Base ID # | OVP Base Port # |
|----------------------|-------|------------|----------------|-------------------|---------------|-----------------|
| 1 | | | | | | |
| 2 | | | | | | |
| 3 | | | | | | |
| 4 | | | | | | |
| 5 | | | | | | |
| 6 | | | | | | |
| 7 | | | | | | |
| 8 | | | | | | |
| 9 | | | | | | |
| 10 | | | | | | |
| 11 | | | | | | |
| 12 | | | | | | |

Date: _____

Contractor: _____

Section 9: Rack Installation

- 1) Determine the installation depth required for the base unit, attach the side flanges in the appropriate location. 9 screws are required per side.
- 2) Mount the unit in a standard 19" rack near the current DC power output breaker box.
- 3) Ground the unit by installing a 6AWG ground wire at the back of the unit.
- 4) Based on the Raycap model numbers, use the applicable Raycap installation instructions to install the Raycap top and bottom OVP hardware, and the associated power and data cabling.

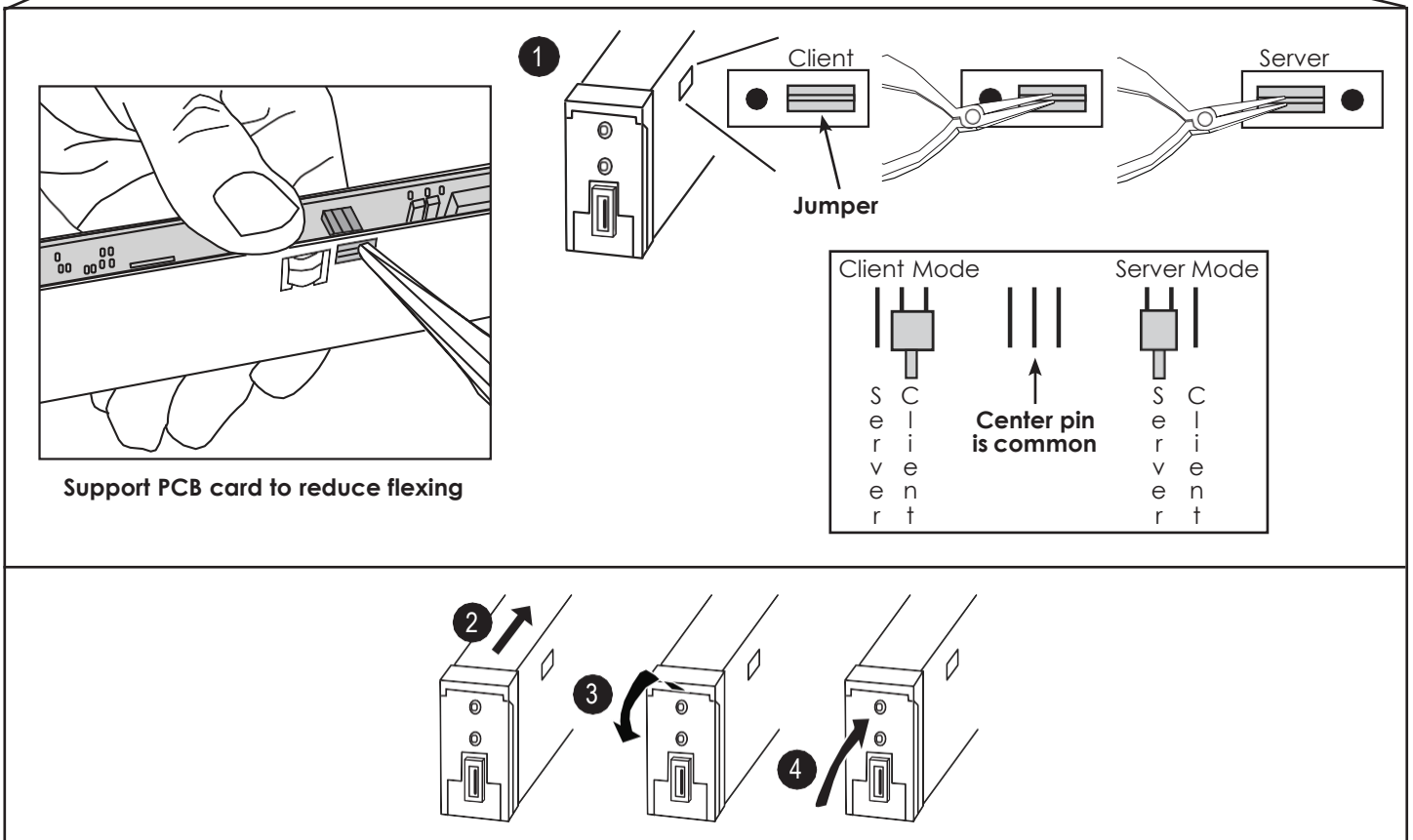
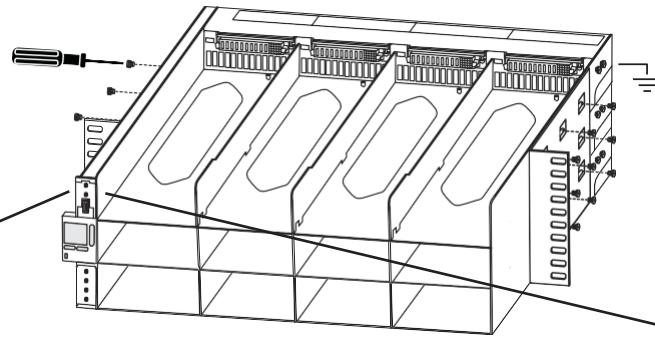

Controller and RS485 card Installation

Install the Controller and RS485 cards into the shelf as follows

- 1) Unbox the Controller but do not remove it from the anti-static bag
- 2) Using an ESD protective wrist strap, ground yourself to the PowerShift chassis
- 3) Remove the Controller from the anti-static bag, locate the jumper on the side of card. Span thumb across the PCB and the metal frame, thereby keeping the PCB from flexing when you change the jumper. Change the jumper from Client (factory default) to Server **1** by using needle nose pliers to pull and re-insert the jumper.
- 4) Slide the controller card halfway into the slot, **2** open the front latch, **3** then slide the controller all the way in until you feel the backplane connector fully seat; close the latch. **4**
- 5) Unbox the RS485 protocol converter card, again using the ESD strap, install the card halfway, **2** open the latch, **3** then fully seat the card and close the latch **4** (there is no jumper to set on this card).

Note: The Controller card and RS485 card have similar form factors and therefore can be inserted into either the top or bottom shelf slot. However, the shelf interface will only allow them to be fully seated and latched when they are inserted into the correct slot (Controller on top, RS485 on bottom)

Section 10: Wiring of the Rack

Note: For ease of access, install alarm cables (if required) and RS485 data cable before installing power cables:

- 1) If required, install dry-contact alarm relay wiring from back of shelf to site alarm block.

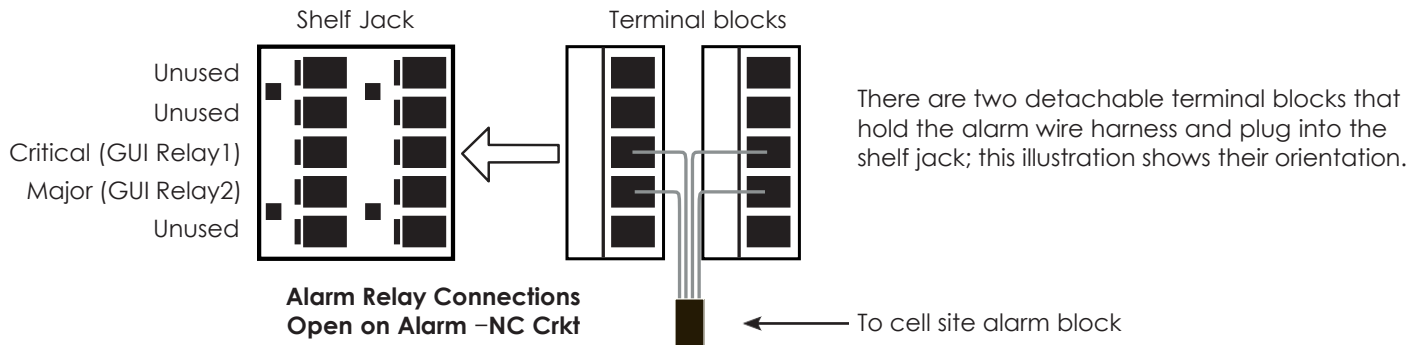

- 2) Install RS485 data cable between the Raycap base unit (VBOOST OUTPUT port) and the PowerShift shelf (R1 port); use a standard Ethernet patch cable (the cable included with Raycap RCMDC-6627-PF-48 can be used)

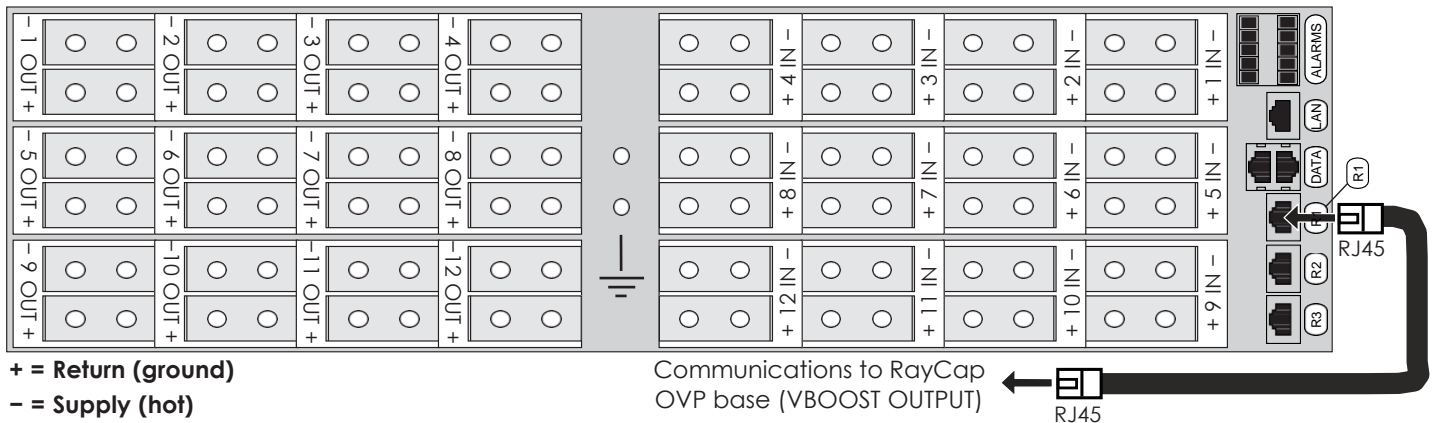

RS485 data cable; use standard Ethernet cable or use the cable included with Raycap RCMDC=627-PF-48

- 3) As shown above, the rear of the shelf is divided into 24 individual circuits, each containing a two wire DC input and a two wire DC output. There is a positive and negative terminal strip connection for each DC input and out. Terminate the power cables with a dual-hole lug as shown below.

Lug Preparation

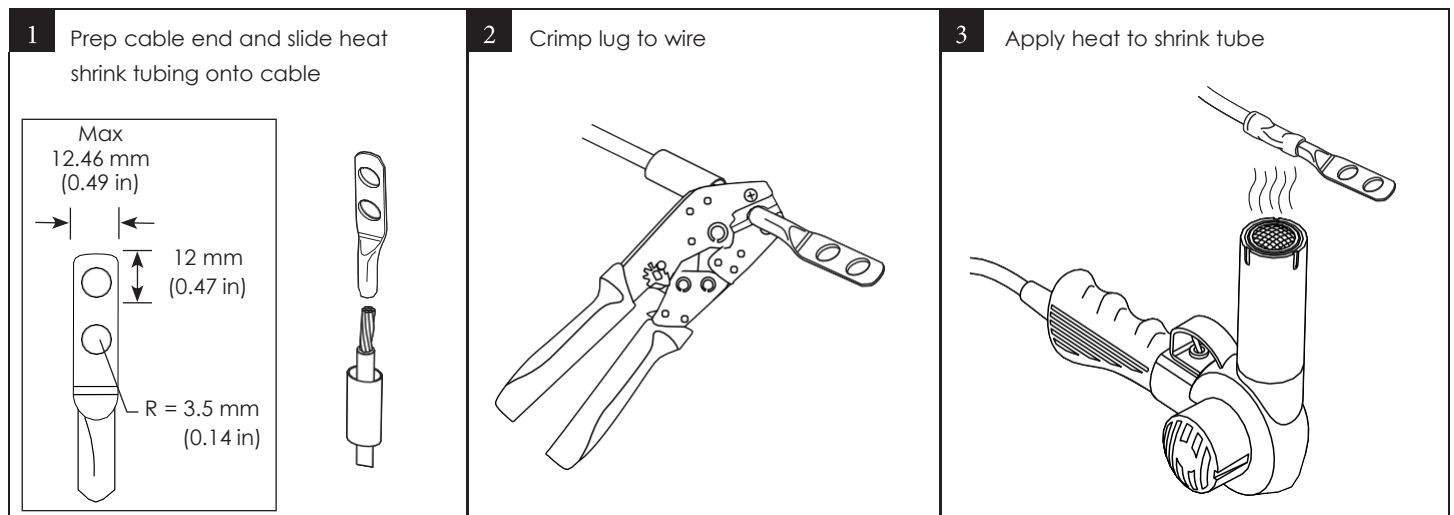

Wiring Sequence

Note: Connect PowerShift input and output power cables using the wiring sequence shown below (outside to inside, bottom to top); this is recommended based on the typical route of input and output cable into a rack (i.e., cables usually run from top of rack downward to PowerShift shelf).

- 1) Attach site DC power supply lines from the distribution panel to the input terminals on PowerShift rack
- 2) Attach power output cables from the PowerShift rack to the OVP base panel/box.
- 3) Repeat for each circuit. Recommend completely wiring all input and output cable pairs into the shelf during installation, even if 12 modules are not being installed; this will ease future installation of additional radios.

**Wiring Sequence A-L
(outside to inside, bottom to top)**

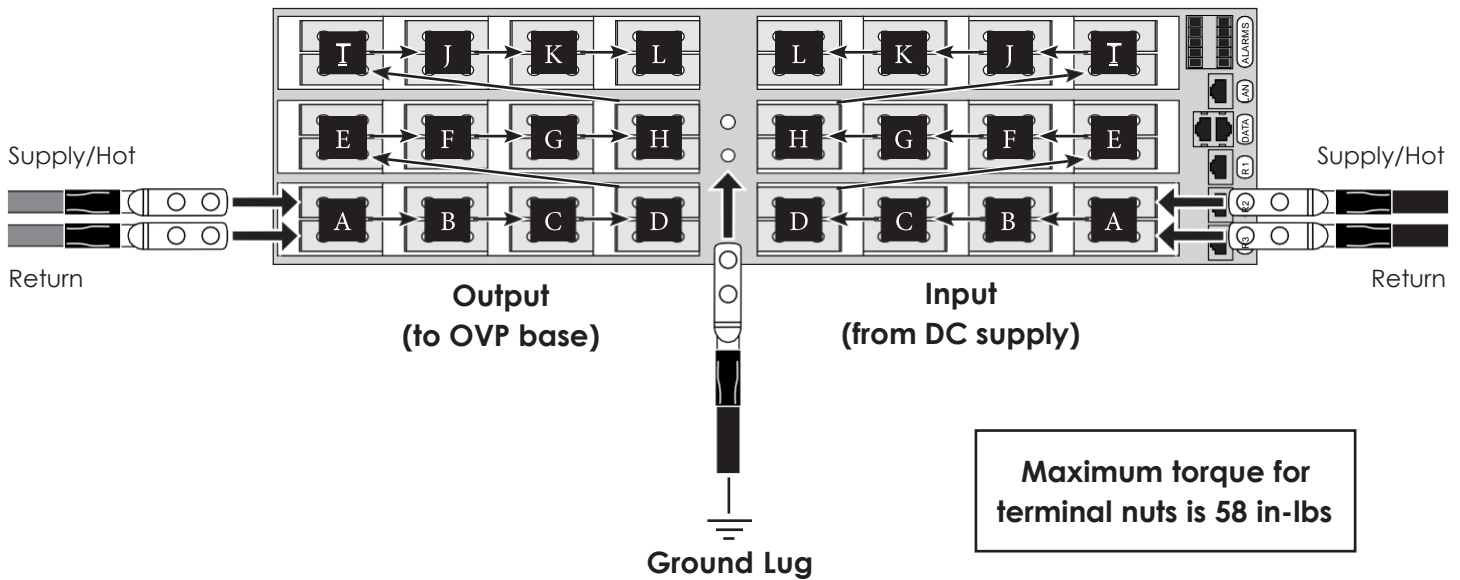

Section 11: Power Up and Configuration Procedure

Note: Module Hot Swap

If a boost module is installed and operating normally (input and output LEDs are green) then the associated bypass module can be removed and power to the radio will be maintained for both circuits

If a bypass module is installed and operating normally (all its LEDs are green) then the associated boost module can be removed; both circuits will switch to the bypass module and power to the radio will be maintained

The controller card and the RS485 card can both be hot swapped while the system is operational, power to the radios will not be interrupted. However note the following:

- The boost modules will continue to adjust their boosted voltage output based on the load current demanded by the radio
- However, if there are other large changes to circuit conditions, such as a significant change in cable resistance, operational adjustments will not be made until both the controller and RS485 are installed

Apply Input Power

- 1) Turn on DC plant circuit breaker for PowerShift Circuit 01, confirm activation of the Controller, LCD Display and RS485 Protocol Converter card

Note: The Controller, Display and RS485 card obtain power from the Shelf input terminals for circuits 1, 2, 5, 6, 9 or 10; at least one of these circuits must have input power applied. A module does not need to be installed in the Shelf slot (the power is obtained from the input terminals, not from the boost module or bypass module)

- 2) The Controller and RS485 LEDs should cycle off and on, the LCD display backlight should illuminate
- 3) After 10-30 seconds:
 - a) The Controller card SYS LED should illuminate solid green or red
 - b) The Display should show the text "U" in the center/left of the screen (the backlight may be either green, yellow or red)



- c) The RS485 card ALM LED should illuminate solid green
- d) The RS485 card R1 LED will not illuminate until output power from the Shelf is applied to at least one circuit on the OVP base
- 4) Use a Windows PC and web browser (Chrome is preferred) to connect to the LAN port on the back of the PowerShift Shelf
 - a) Connect a standard Ethernet patch cable between the PC and the Shelf LAN port; the PC Ethernet port LED should illuminate
 - b) The PC must be configured for DHCP operation on its Ethernet port
 - c) In a prior step the Controller hardware jumper should have been set for "Server" operation
- 5) Open web browser on the PC and enter URL: 192.168.2.1, the GUI login page appears:

Note: When the Controller is powered up it may take 1-2 minutes before the web browser can connect, and then it may take 30 seconds or longer for the login page to appear

Troubleshooting: If the login page does not appear, open a command prompt (cmd) in Windows and use the following ping command to confirm a good connection to the controller: ping http://192.168.2.1



- 6) Enter the password: super-user (lower case, no spaces)
 - a) The default login does not require a user name, only a password
 - b) Click Submit, the GUI Home page appears:
 - c) Confirm the controller software version is 4.5.11 or higher
 - d) Click on the Installation tab, adjust the time and date, enter the site ID and description (e.g., site name or street address); click the Submit button

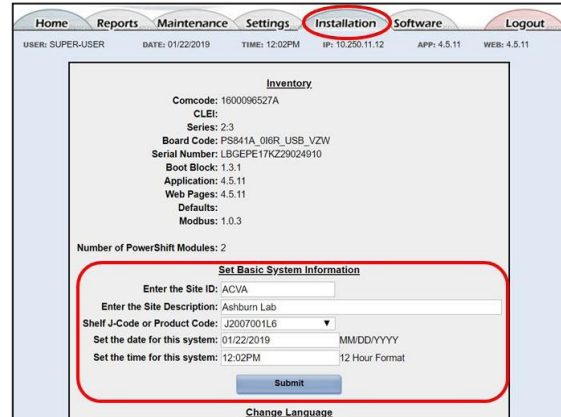
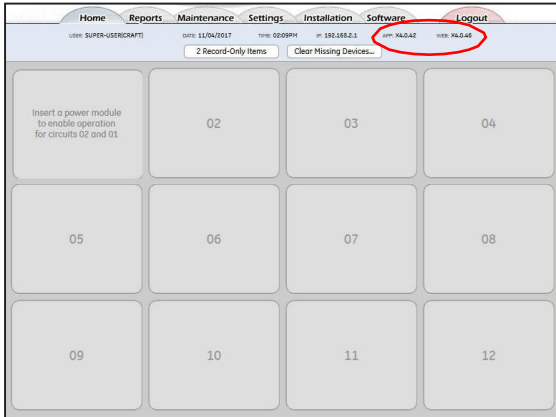

- 7) If it is required to disable a Controller communication port for security purposes (such as HTTP), then use the following steps:
 - a) In the GUI, click on the Settings tab, then click on the Security hotlink
 - b) Under Enabled Network Ports, uncheck ports to disable them

Warning: If you uncheck “Enable HTTP” and submit the change, the port will be disabled and you will lose the GUI connection; you will then need to use HTTPS to connect (//https:192.168.2.1)

- c) Click the Submit button

Inserting Modules

- 1 Slide module partially into rack slot.
 - 2 press metal release tab to open front cover, slide module into rack until it stops.
 - 3 Close the front cover on the module to make connection and lock into place. Repeat with any remaining modules.
- The modules operate individually so slots may be left open for future expansion.

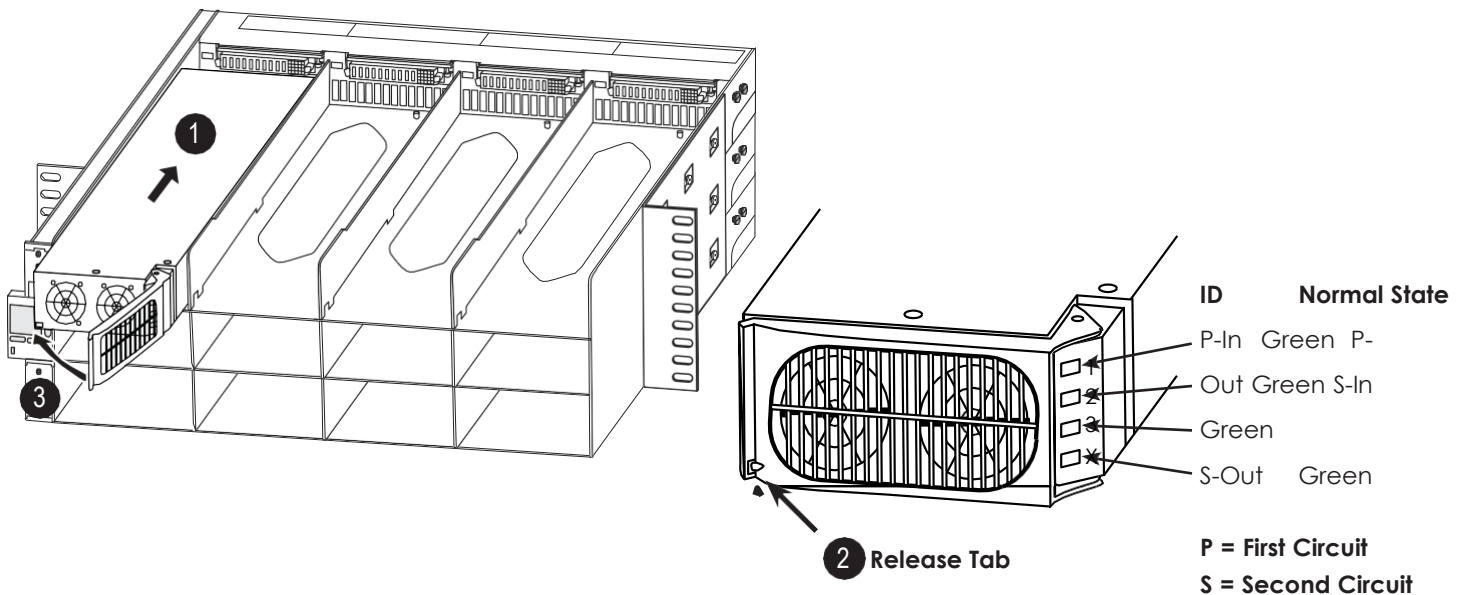

- 8) Insert a Boost module into Shelf slot 01, the following Shelf LED behavior should occur:
 - a) Module input LED (P-In) blinks yellow and output LED (P-Out) blinks red
 - b) After 10-30 seconds both LEDs change to solid green; this is the normal state and indicates output power is now active to the OVP base



Troubleshooting Note: If the R1 LED on the RS485 card is dark then troubleshoot as follows:

- Confirm RS485 data cable is connected between PowerShift Shelf R1 port and the OVP base VBOOST OUTPUT port
- Confirm the OVP base selector switch is set to a Base Mode position 2-6

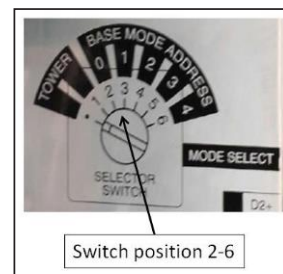

- 9) If a remote radio is connected, the radio should power on
- 10) Confirm the OVP base LED voltage display shows the lower and upper voltage measurements
 - a) On the base OVP, press the Wake/Adv button one time and release (above image is for a dome OVP, a rackmount OVP will have a different button configuration)

- b) The display should toggle between L1 (lower voltage) and U1 (upper voltage) values
- L1 should be 56V or higher
 - U1 will typically be 54-56V, but may be lower until the remaining steps are completed
 - Examples:

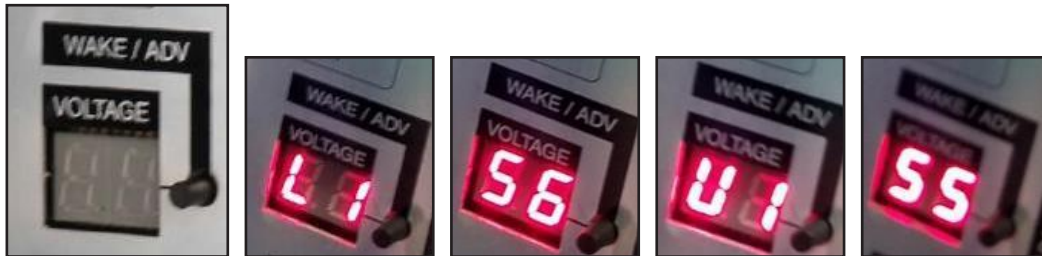

Note: See Section 13 for detailed guidance on troubleshooting Raycap OVP issues

- 11) In the PowerShift GUI Home page, confirm the circuit 01 inset box is green, indicating it has input power applied; if a radio is connected and powered on then the GUI will show the load current:

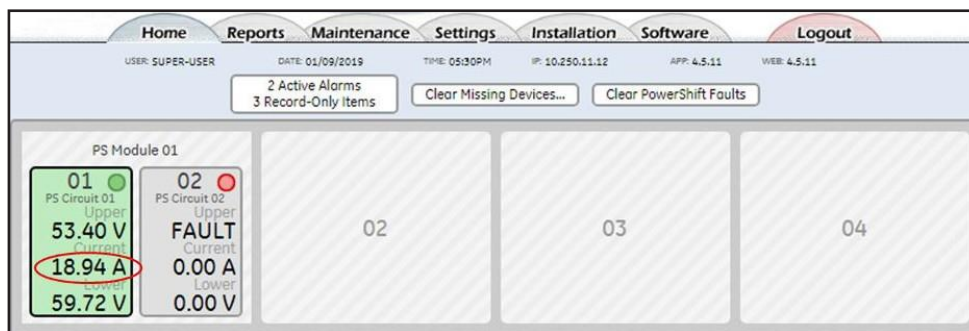

Perform OVP Circuit Assignment

- 12) The following steps describe an OVP circuit assignment using the PowerShift GUI; explanation:
- The PowerShift Shelf is receiving the upper voltage measurement from the OVP base
 - This next step assigns that measurement to the applicable Shelf circuit (Circuit 01 in this case)
 - Once the assignment is made, PowerShift will adjust its output voltage based on the upper measurement voltage reported by the OVP

Note:

The GUI is pre-configured with an OVP circuit assignment for a 12 RRU Tower Top configuration (see Section 4) –i.e. two OVP base units and one OVP top unit. If this matches your site configuration then it should not be necessary to make any circuit assignment changes, however it is still best to use the following steps to confirm the configuration.

13) In the GUI Home page, the OVP circuit assignments are made by clicking anywhere inside the circuit box



14) The circuit information pop-up box is displayed; the annotated labels describe the circuit information provided

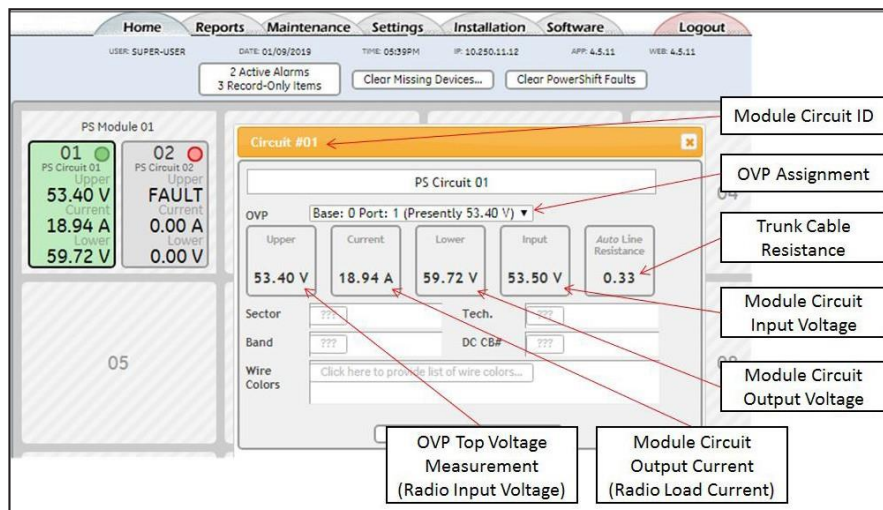

15) Click on the OVP Assignment box to display the list of available OVP upper voltage measurements; note the following using the example below:

- “Base: 0” is the address of the OVP base unit that receives the upper voltage measurement and sends it to the PowerShift shelf
- “Port: 1” identifies the port number of the OVP top unit that sends the upper voltage measurement to the OVP base unit

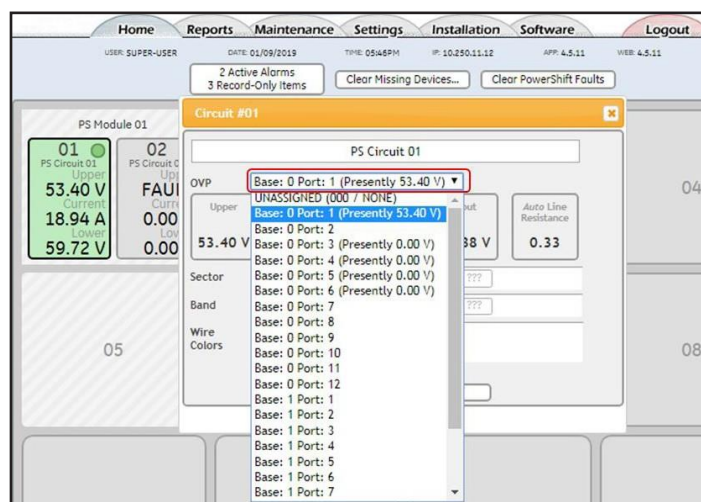

- 16) Select the applicable OVP assignment from the list
 - a) Scroll down the list as needed to find and click on the desired OVP base ID and port number
 - b) Click the "X" in the upper right corner to close the OVP assignment box and return to the Home page

- 17) Check LCD Display to confirm the Upper Voltage measurement is displayed; following is an example after assignments are made for Circuit 01 and 02



Note: The LCD main screen displays the upper voltage measurements for each circuit (01-12) after the upper voltage has been assigned to a Shelf circuit. The voltages are displayed in a 4x3 grid; example:

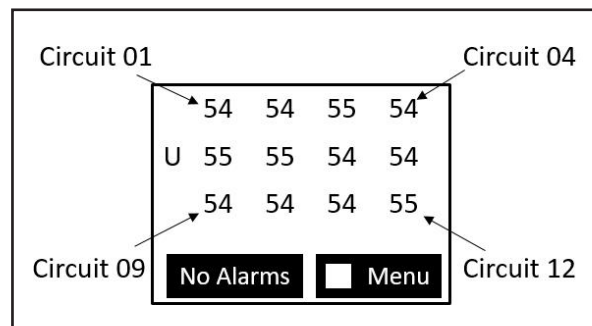

Perform Measurement Sanity Check

- 18) Using the GUI, perform a sanity check on the detailed circuit measurements using the following guidelines:
 - a) Input Voltage: Roughly equal to DC plant rectifier float voltage; typically about 54.0V to 54.5V
 - b) Lower Voltage: Around 56V or higher; the longer the trunk cable and greater the radio power demand, the greater the voltage (e.g. ~65V for 1500W RRU load and 500ft of 6-AWG)
 - c) Upper Voltage: 53.5 +/- 3V
 - d) Output Current: Greater than 0; exact value will vary significantly depending on radio model and user traffic demand
 - e) Auto Line Resistance: Varies depending on cable length and gauge; very general guideline is between 0.10 and 0.20 (may be higher for very long cable lengths and/or lighter cable gauge)

Insert Bypass Module and Test

19) Insert a Bypass Module into Shelf slot 02; the following LED behavior should occur:

- Bypass module input LED (P-In) blinks yellow and output LED (P-Out) blinks red
- After 10-30 seconds both LEDs change to solid green; this the normal state and indicates the bypass circuit is functional and available to provide bypass, but is not currently engaged
- Confirm the Boost module input LED (P-In) and output LED (P-Out) remain solid green



The GUI displays the following:

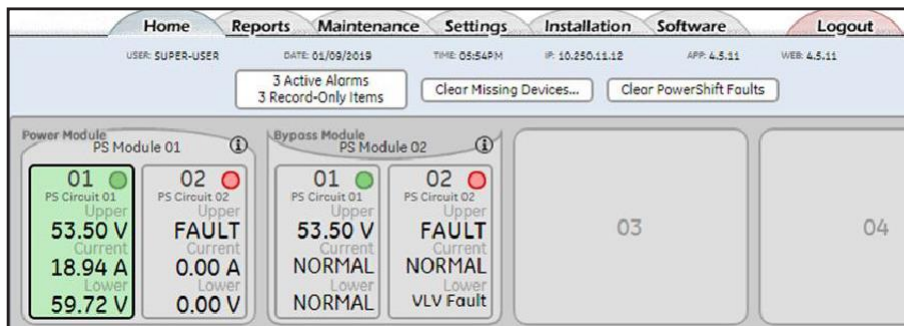

20) Test the bypass function is working properly by unseating the Boost module in shelf slot 01 as follows:

- Press the metal tab on lower left of Boost module front bezel, the latch will flip outward
- Lever the latch outward until the Boost module unseats and its LEDs go dark
- On the Bypass Module, confirm the input LED (P-In) remains solid green, and confirm the output LED (P-Out) changes to solid yellow; this indicates the circuit is now in bypass
- Confirm the OVP voltage display continues to show a non-zero voltage for L1 and U1
- The GUI will show the Boost module is removed from Slot 01; any load current on the circuit it is now supplied by the Bypass Module in Slot 02

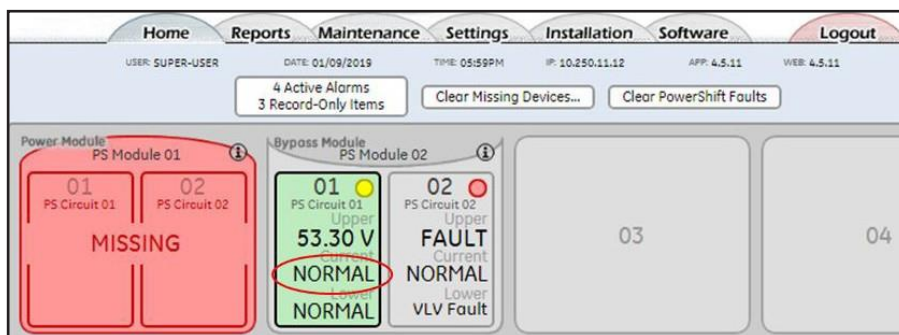

21) Insert the Boost module back into its slot, the following behavior should occur:

- The Boost module and Bypass module input and output LEDs return to the previous normal state, solid green
- Confirm the OVP L1 voltage display continues to show minimum 56V, and confirm the U1 voltage is showing 54V-56V
- In the GUI, confirm any load current has transitioned from the Bypass Module (Slot 02) back to the Boost module (Slot 01)

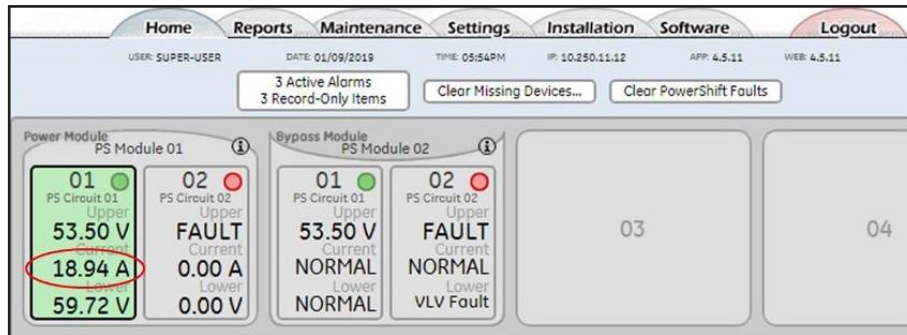

Enter Radio Information

22) In the GUI circuit pop-up box, enter the radio information (sector, technology, band) and enter the ID for the DC plant circuit breaker that provides input power to the shelf. A color code for the trunk cable can also be entered.

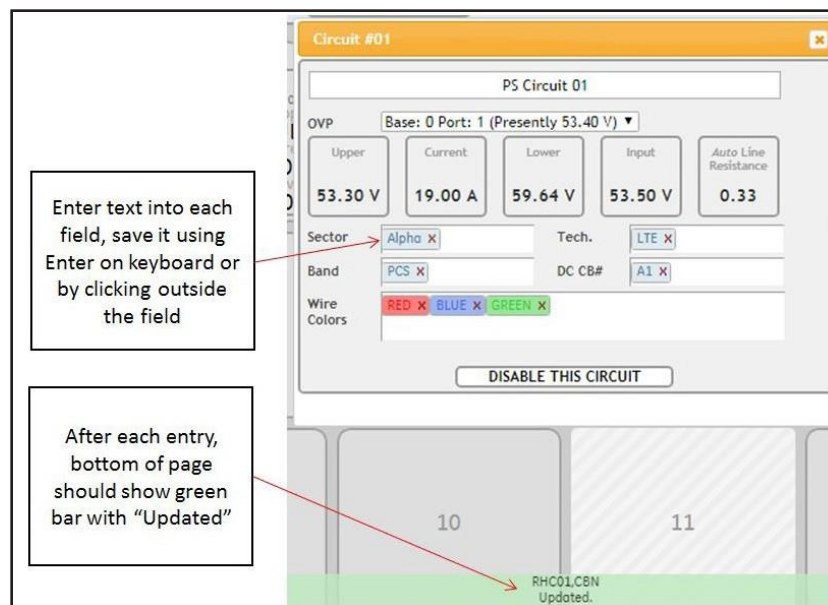

Power Up Remaining Circuits

23) Repeat the previous steps for each circuit, one circuit at a time:

- Turn on the circuit breaker
- Insert additional Boost module as needed
- Confirm the OVP base displays lower and upper voltage measurements
- Perform the OVPRM circuit assignment
- Confirm the LCD Display shows the circuit measurements
- Perform sanity check on circuit measurements
- Insert additional Bypass Module as needed and test bypass circuit
- Enter the radio information for the circuit into the GUI

Disabling a Circuit

- 24) In some cases there will be one circuit in a PowerShift module that is powered, but the second circuit is unpowered (no radio is installed on the circuit)
- 25) In this case it is necessary to disable the unpowered circuit using the GUI
- 26) In the GUI, click inside the Boost module box of the circuit that is to be disabled (Slot 01, Circuit 02, in this example), then click on the button "Disable this Circuit"; confirm the prompt to disable the circuit

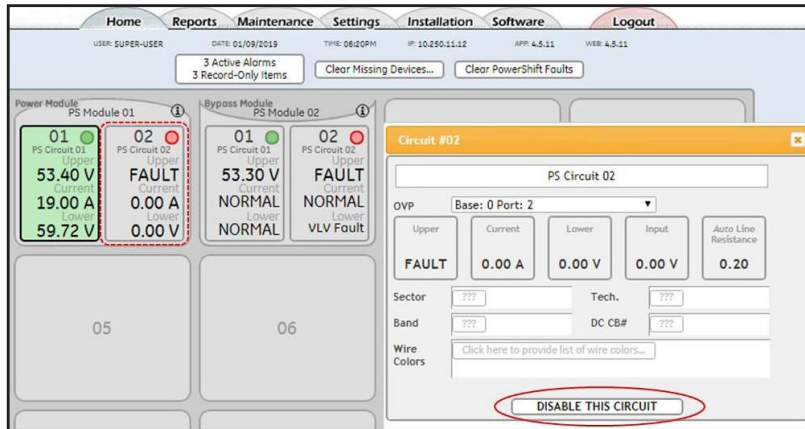

- 27) The GUI will show the circuit as disabled; the Boost module and Bypass Module input and output LEDs for the circuit will turn off.

Note: If input power is subsequently applied to this circuit, the Power and Bypass modules will activate (they will override the disabled state in the GUI)

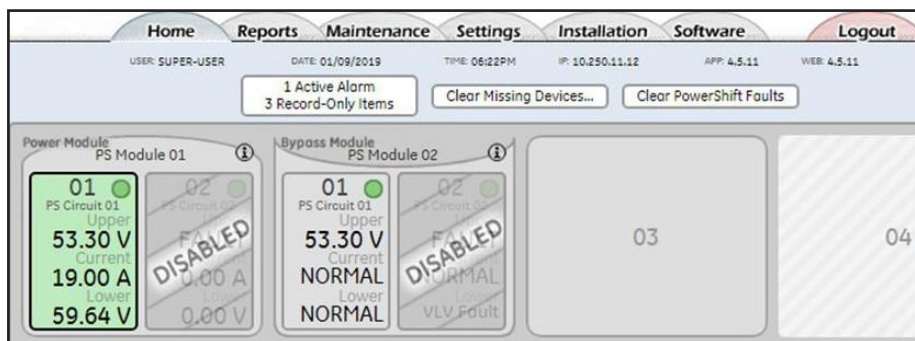

Uninstall A Bypass Module

- 28) Once a bypass module has been installed into a shelf slot and at least one circuit has input power applied, if the module is then removed from the shelf or if it is powered off then the controller will flag it as "MISSING".

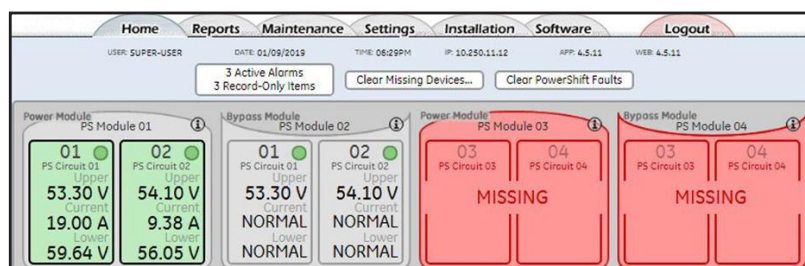

29) In order to clear the "MISSING" flag, click on the button "Clear Missing Devices"

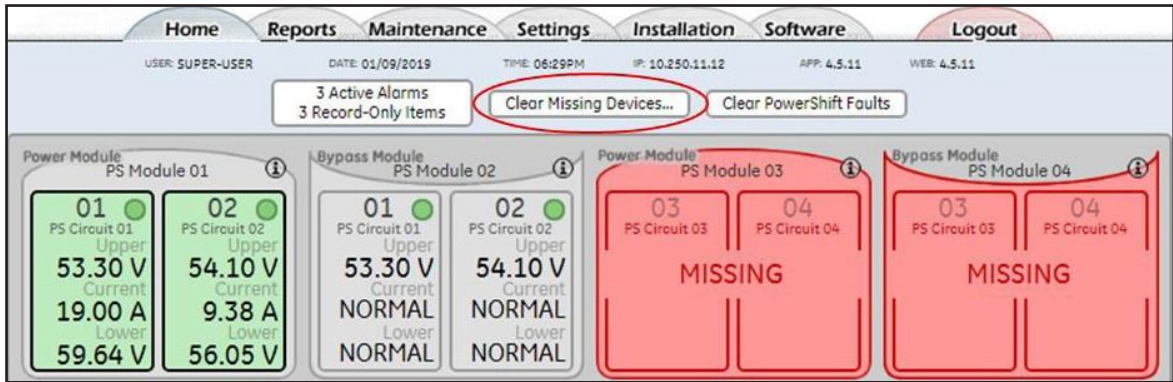

Configure Alarm Notification

30) In the GUI, click on the Settings tab, then click on the Alarm Notification link

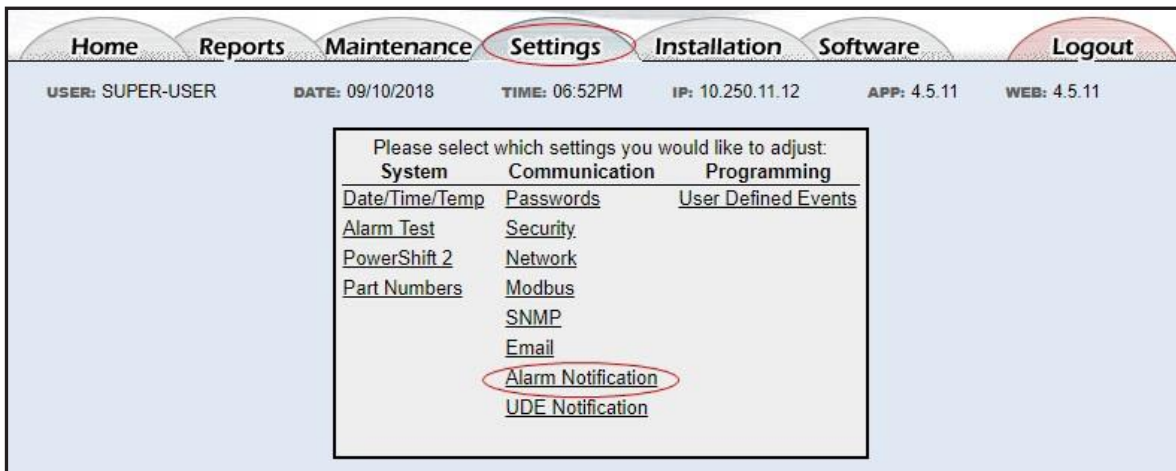

31) In the Alarm Notification page, ensure the severity ("Sev.") and Relay columns are configured for each alarm section as shown in the screen captures below:

32) System Alarms

| Notify Settings | | | | | | | | | | | | | | | | | | | |
|---|-------|-------|-----|--------------------------|--------------------------|--------------------------|--------------------------|--------------------------|--------------------------|--------------------------|--------------------------|--------------------------|--------------------------|--------------------------|--------------------------|--------------------------|--------------------------|--------------------------|----|
| USER: SUPER-USER DATE: 09/10/2018 TIME: 04:08PM IP: 10.250.11.12 APP: 4.5.11 WEB: 4.5.11 | | | | | | | | | | | | | | | | | | | |
| System Alarms | | | | | | | | | | | | | | | | | | | |
| ID | Sev. | Relay | LED | EMAIL | | | | SNMP | | | | PHONE | | | | Delay | | | |
| | | | | 1 | 2 | 3 | 4 | 1 | 2 | 3 | 4 | 1 | 2 | 3 | 4 | O | R | N | |
| High Ambient Temperature | AMTH1 | MAJ | R2 | <input type="checkbox"/> | <input type="checkbox"/> | <input type="checkbox"/> | <input type="checkbox"/> | <input type="checkbox"/> | <input type="checkbox"/> | <input type="checkbox"/> | <input type="checkbox"/> | <input type="checkbox"/> | <input type="checkbox"/> | <input type="checkbox"/> | <input type="checkbox"/> | <input type="checkbox"/> | <input type="checkbox"/> | <input type="checkbox"/> | 0s |
| Low Ambient Temperature | AMTL1 | MAJ | R2 | <input type="checkbox"/> | <input type="checkbox"/> | <input type="checkbox"/> | <input type="checkbox"/> | <input type="checkbox"/> | <input type="checkbox"/> | <input type="checkbox"/> | <input type="checkbox"/> | <input type="checkbox"/> | <input type="checkbox"/> | <input type="checkbox"/> | <input type="checkbox"/> | <input type="checkbox"/> | <input type="checkbox"/> | <input type="checkbox"/> | 0s |
| Config Reboot Required | CRT1 | CRIT | R1 | <input type="checkbox"/> | <input type="checkbox"/> | <input type="checkbox"/> | <input type="checkbox"/> | <input type="checkbox"/> | <input type="checkbox"/> | <input type="checkbox"/> | <input type="checkbox"/> | <input type="checkbox"/> | <input type="checkbox"/> | <input type="checkbox"/> | <input type="checkbox"/> | <input type="checkbox"/> | <input type="checkbox"/> | <input type="checkbox"/> | 0s |
| Auxiliary Major | AMJ1 | CRIT | R1 | <input type="checkbox"/> | <input type="checkbox"/> | <input type="checkbox"/> | <input type="checkbox"/> | <input type="checkbox"/> | <input type="checkbox"/> | <input type="checkbox"/> | <input type="checkbox"/> | <input type="checkbox"/> | <input type="checkbox"/> | <input type="checkbox"/> | <input type="checkbox"/> | <input type="checkbox"/> | <input type="checkbox"/> | <input type="checkbox"/> | 0s |
| Alarm Test Active | ATA1 | RO | | <input type="checkbox"/> | <input type="checkbox"/> | <input type="checkbox"/> | <input type="checkbox"/> | <input type="checkbox"/> | <input type="checkbox"/> | <input type="checkbox"/> | <input type="checkbox"/> | <input type="checkbox"/> | <input type="checkbox"/> | <input type="checkbox"/> | <input type="checkbox"/> | <input type="checkbox"/> | <input type="checkbox"/> | <input type="checkbox"/> | 0s |
| Alarm Test Aborted | ATB1 | RO | | <input type="checkbox"/> | <input type="checkbox"/> | <input type="checkbox"/> | <input type="checkbox"/> | <input type="checkbox"/> | <input type="checkbox"/> | <input type="checkbox"/> | <input type="checkbox"/> | <input type="checkbox"/> | <input type="checkbox"/> | <input type="checkbox"/> | <input type="checkbox"/> | <input type="checkbox"/> | <input type="checkbox"/> | <input type="checkbox"/> | 0s |
| Real Time Clock Battery Low | BBL1 | WRN | | <input type="checkbox"/> | <input type="checkbox"/> | <input type="checkbox"/> | <input type="checkbox"/> | <input type="checkbox"/> | <input type="checkbox"/> | <input type="checkbox"/> | <input type="checkbox"/> | <input type="checkbox"/> | <input type="checkbox"/> | <input type="checkbox"/> | <input type="checkbox"/> | <input type="checkbox"/> | <input type="checkbox"/> | <input type="checkbox"/> | 0s |
| Configuration Changed | CCH1 | RO | | <input type="checkbox"/> | <input type="checkbox"/> | <input type="checkbox"/> | <input type="checkbox"/> | <input type="checkbox"/> | <input type="checkbox"/> | <input type="checkbox"/> | <input type="checkbox"/> | <input type="checkbox"/> | <input type="checkbox"/> | <input type="checkbox"/> | <input type="checkbox"/> | <input type="checkbox"/> | <input type="checkbox"/> | <input type="checkbox"/> | 0s |
| Clock Changed | CLC1 | RO | | <input type="checkbox"/> | <input type="checkbox"/> | <input type="checkbox"/> | <input type="checkbox"/> | <input type="checkbox"/> | <input type="checkbox"/> | <input type="checkbox"/> | <input type="checkbox"/> | <input type="checkbox"/> | <input type="checkbox"/> | <input type="checkbox"/> | <input type="checkbox"/> | <input type="checkbox"/> | <input type="checkbox"/> | <input type="checkbox"/> | 0s |
| ID Conflict | DID1 | CRIT | R1 | <input type="checkbox"/> | <input type="checkbox"/> | <input type="checkbox"/> | <input type="checkbox"/> | <input type="checkbox"/> | <input type="checkbox"/> | <input type="checkbox"/> | <input type="checkbox"/> | <input type="checkbox"/> | <input type="checkbox"/> | <input type="checkbox"/> | <input type="checkbox"/> | <input type="checkbox"/> | <input type="checkbox"/> | <input type="checkbox"/> | 0s |
| Excessive Login Attempts | EXL1 | WRN | | <input type="checkbox"/> | <input type="checkbox"/> | <input type="checkbox"/> | <input type="checkbox"/> | <input type="checkbox"/> | <input type="checkbox"/> | <input type="checkbox"/> | <input type="checkbox"/> | <input type="checkbox"/> | <input type="checkbox"/> | <input type="checkbox"/> | <input type="checkbox"/> | <input type="checkbox"/> | <input type="checkbox"/> | <input type="checkbox"/> | 0s |
| History Cleared | HCL1 | RO | | <input type="checkbox"/> | <input type="checkbox"/> | <input type="checkbox"/> | <input type="checkbox"/> | <input type="checkbox"/> | <input type="checkbox"/> | <input type="checkbox"/> | <input type="checkbox"/> | <input type="checkbox"/> | <input type="checkbox"/> | <input type="checkbox"/> | <input type="checkbox"/> | <input type="checkbox"/> | <input type="checkbox"/> | <input type="checkbox"/> | 0s |
| Password At Default | PFD1 | RO | | <input type="checkbox"/> | <input type="checkbox"/> | <input type="checkbox"/> | <input type="checkbox"/> | <input type="checkbox"/> | <input type="checkbox"/> | <input type="checkbox"/> | <input type="checkbox"/> | <input type="checkbox"/> | <input type="checkbox"/> | <input type="checkbox"/> | <input type="checkbox"/> | <input type="checkbox"/> | <input type="checkbox"/> | <input type="checkbox"/> | 0s |
| Processor Halt | PHT1 | RO | | <input type="checkbox"/> | <input type="checkbox"/> | <input type="checkbox"/> | <input type="checkbox"/> | <input type="checkbox"/> | <input type="checkbox"/> | <input type="checkbox"/> | <input type="checkbox"/> | <input type="checkbox"/> | <input type="checkbox"/> | <input type="checkbox"/> | <input type="checkbox"/> | <input type="checkbox"/> | <input type="checkbox"/> | <input type="checkbox"/> | 0s |
| Self Test Failed | STF1 | MAJ | R2 | <input type="checkbox"/> | <input type="checkbox"/> | <input type="checkbox"/> | <input type="checkbox"/> | <input type="checkbox"/> | <input type="checkbox"/> | <input type="checkbox"/> | <input type="checkbox"/> | <input type="checkbox"/> | <input type="checkbox"/> | <input type="checkbox"/> | <input type="checkbox"/> | <input type="checkbox"/> | <input type="checkbox"/> | <input type="checkbox"/> | 0s |
| ID Not Configured | ZID1 | CRIT | R1 | <input type="checkbox"/> | <input type="checkbox"/> | <input type="checkbox"/> | <input type="checkbox"/> | <input type="checkbox"/> | <input type="checkbox"/> | <input type="checkbox"/> | <input type="checkbox"/> | <input type="checkbox"/> | <input type="checkbox"/> | <input type="checkbox"/> | <input type="checkbox"/> | <input type="checkbox"/> | <input type="checkbox"/> | <input type="checkbox"/> | 0s |

Click buttons to change

33) Power Express

Note: The Power Express section can be left as is (it is not applicable for PowerShift)

| Power Express | | | | | | | | | | | | | | | | | | | |
|--|-------|-------|-----|--------------------------|--------------------------|--------------------------|--------------------------|--------------------------|--------------------------|--------------------------|--------------------------|--------------------------|--------------------------|--------------------------|--------------------------|--------------------------|--------------------------|--------------------------|----|
| ID | Sev. | Relay | LED | EMAIL | | | | SNMP | | | | PHONE | | | | Delay | | | |
| | | | | 1 | 2 | 3 | 4 | 1 | 2 | 3 | 4 | 1 | 2 | 3 | 4 | O | R | N | |
| PE ID Conflict | PEID1 | MIN | | <input type="checkbox"/> | <input type="checkbox"/> | <input type="checkbox"/> | <input type="checkbox"/> | <input type="checkbox"/> | <input type="checkbox"/> | <input type="checkbox"/> | <input type="checkbox"/> | <input type="checkbox"/> | <input type="checkbox"/> | <input type="checkbox"/> | <input type="checkbox"/> | <input type="checkbox"/> | <input type="checkbox"/> | <input type="checkbox"/> | 0s |
| PE Internal Circuit Fail | DIF1 | MAJ | | <input type="checkbox"/> | <input type="checkbox"/> | <input type="checkbox"/> | <input type="checkbox"/> | <input type="checkbox"/> | <input type="checkbox"/> | <input type="checkbox"/> | <input type="checkbox"/> | <input type="checkbox"/> | <input type="checkbox"/> | <input type="checkbox"/> | <input type="checkbox"/> | <input type="checkbox"/> | <input type="checkbox"/> | <input type="checkbox"/> | 0s |
| PE Over Power Shutdown | OPS1 | MAJ | | <input type="checkbox"/> | <input type="checkbox"/> | <input type="checkbox"/> | <input type="checkbox"/> | <input type="checkbox"/> | <input type="checkbox"/> | <input type="checkbox"/> | <input type="checkbox"/> | <input type="checkbox"/> | <input type="checkbox"/> | <input type="checkbox"/> | <input type="checkbox"/> | <input type="checkbox"/> | <input type="checkbox"/> | <input type="checkbox"/> | 0s |
| PE Over Current Shutdown | OCS1 | MAJ | | <input type="checkbox"/> | <input type="checkbox"/> | <input type="checkbox"/> | <input type="checkbox"/> | <input type="checkbox"/> | <input type="checkbox"/> | <input type="checkbox"/> | <input type="checkbox"/> | <input type="checkbox"/> | <input type="checkbox"/> | <input type="checkbox"/> | <input type="checkbox"/> | <input type="checkbox"/> | <input type="checkbox"/> | <input type="checkbox"/> | 0s |
| PE Short Circuit Shutdown | SCS1 | MAJ | | <input type="checkbox"/> | <input type="checkbox"/> | <input type="checkbox"/> | <input type="checkbox"/> | <input type="checkbox"/> | <input type="checkbox"/> | <input type="checkbox"/> | <input type="checkbox"/> | <input type="checkbox"/> | <input type="checkbox"/> | <input type="checkbox"/> | <input type="checkbox"/> | <input type="checkbox"/> | <input type="checkbox"/> | <input type="checkbox"/> | 0s |
| PE Input Out of Range | IOR1 | MAJ | | <input type="checkbox"/> | <input type="checkbox"/> | <input type="checkbox"/> | <input type="checkbox"/> | <input type="checkbox"/> | <input type="checkbox"/> | <input type="checkbox"/> | <input type="checkbox"/> | <input type="checkbox"/> | <input type="checkbox"/> | <input type="checkbox"/> | <input type="checkbox"/> | <input type="checkbox"/> | <input type="checkbox"/> | <input type="checkbox"/> | 0s |
| PE Over Temperature Shutdown | OTS1 | MAJ | | <input type="checkbox"/> | <input type="checkbox"/> | <input type="checkbox"/> | <input type="checkbox"/> | <input type="checkbox"/> | <input type="checkbox"/> | <input type="checkbox"/> | <input type="checkbox"/> | <input type="checkbox"/> | <input type="checkbox"/> | <input type="checkbox"/> | <input type="checkbox"/> | <input type="checkbox"/> | <input type="checkbox"/> | <input type="checkbox"/> | 0s |
| PE Load Dropped | LDR1 | MAJ | | <input type="checkbox"/> | <input type="checkbox"/> | <input type="checkbox"/> | <input type="checkbox"/> | <input type="checkbox"/> | <input type="checkbox"/> | <input type="checkbox"/> | <input type="checkbox"/> | <input type="checkbox"/> | <input type="checkbox"/> | <input type="checkbox"/> | <input type="checkbox"/> | <input type="checkbox"/> | <input type="checkbox"/> | <input type="checkbox"/> | 0s |
| PE Fan Fail | DFAN1 | MAJ | | <input type="checkbox"/> | <input type="checkbox"/> | <input type="checkbox"/> | <input type="checkbox"/> | <input type="checkbox"/> | <input type="checkbox"/> | <input type="checkbox"/> | <input type="checkbox"/> | <input type="checkbox"/> | <input type="checkbox"/> | <input type="checkbox"/> | <input type="checkbox"/> | <input type="checkbox"/> | <input type="checkbox"/> | <input type="checkbox"/> | 0s |
| Input Voltage 1 Reversed | REV1 | MAJ | | <input type="checkbox"/> | <input type="checkbox"/> | <input type="checkbox"/> | <input type="checkbox"/> | <input type="checkbox"/> | <input type="checkbox"/> | <input type="checkbox"/> | <input type="checkbox"/> | <input type="checkbox"/> | <input type="checkbox"/> | <input type="checkbox"/> | <input type="checkbox"/> | <input type="checkbox"/> | <input type="checkbox"/> | <input type="checkbox"/> | 0s |
| Input Voltage 2 Reversed | REV2 | MAJ | | <input type="checkbox"/> | <input type="checkbox"/> | <input type="checkbox"/> | <input type="checkbox"/> | <input type="checkbox"/> | <input type="checkbox"/> | <input type="checkbox"/> | <input type="checkbox"/> | <input type="checkbox"/> | <input type="checkbox"/> | <input type="checkbox"/> | <input type="checkbox"/> | <input type="checkbox"/> | <input type="checkbox"/> | <input type="checkbox"/> | 0s |
| Input Voltage 1 Out of Range | IVOR1 | MAJ | | <input type="checkbox"/> | <input type="checkbox"/> | <input type="checkbox"/> | <input type="checkbox"/> | <input type="checkbox"/> | <input type="checkbox"/> | <input type="checkbox"/> | <input type="checkbox"/> | <input type="checkbox"/> | <input type="checkbox"/> | <input type="checkbox"/> | <input type="checkbox"/> | <input type="checkbox"/> | <input type="checkbox"/> | <input type="checkbox"/> | 0s |
| Input Voltage 2 Out of Range | IVOR2 | MAJ | | <input type="checkbox"/> | <input type="checkbox"/> | <input type="checkbox"/> | <input type="checkbox"/> | <input type="checkbox"/> | <input type="checkbox"/> | <input type="checkbox"/> | <input type="checkbox"/> | <input type="checkbox"/> | <input type="checkbox"/> | <input type="checkbox"/> | <input type="checkbox"/> | <input type="checkbox"/> | <input type="checkbox"/> | <input type="checkbox"/> | 0s |

34) Communication Alarms

| Communication Alarms | ID | Sev. | Relay | LED | EMAIL | | | | SNMP | | | | PHONE | | | | Delay | | |
|--|------|------|-------|--------------------------|--------------------------|--------------------------|--------------------------|--------------------------|--------------------------|--------------------------|--------------------------|--------------------------|--------------------------|--------------------------|--------------------------|--------------------------|--------------------------|--------------------------|----|
| | | | | | 1 | 2 | 3 | 4 | 1 | 2 | 3 | 4 | 1 | 2 | 3 | 4 | | O | R |
| Minor Communication Fail Alarm | CMA1 | MAJ | R2 | <input type="checkbox"/> | <input type="checkbox"/> | <input type="checkbox"/> | <input type="checkbox"/> | <input type="checkbox"/> | <input type="checkbox"/> | <input type="checkbox"/> | <input type="checkbox"/> | <input type="checkbox"/> | <input type="checkbox"/> | <input type="checkbox"/> | <input type="checkbox"/> | <input type="checkbox"/> | <input type="checkbox"/> | <input type="checkbox"/> | 0s |
| Queue Overflow | COF1 | WRN | | <input type="checkbox"/> | <input type="checkbox"/> | <input type="checkbox"/> | <input type="checkbox"/> | <input type="checkbox"/> | <input type="checkbox"/> | <input type="checkbox"/> | <input type="checkbox"/> | <input type="checkbox"/> | <input type="checkbox"/> | <input type="checkbox"/> | <input type="checkbox"/> | <input type="checkbox"/> | <input type="checkbox"/> | <input type="checkbox"/> | 0s |
| No Call-Out Response | COR1 | WRN | | <input type="checkbox"/> | <input type="checkbox"/> | <input type="checkbox"/> | <input type="checkbox"/> | <input type="checkbox"/> | <input type="checkbox"/> | <input type="checkbox"/> | <input type="checkbox"/> | <input type="checkbox"/> | <input type="checkbox"/> | <input type="checkbox"/> | <input type="checkbox"/> | <input type="checkbox"/> | <input type="checkbox"/> | <input type="checkbox"/> | 0s |
| Major Communication Fail Alarm | MCM1 | CRIT | R1 | <input type="checkbox"/> | <input type="checkbox"/> | <input type="checkbox"/> | <input type="checkbox"/> | <input type="checkbox"/> | <input type="checkbox"/> | <input type="checkbox"/> | <input type="checkbox"/> | <input type="checkbox"/> | <input type="checkbox"/> | <input type="checkbox"/> | <input type="checkbox"/> | <input type="checkbox"/> | <input type="checkbox"/> | <input type="checkbox"/> | 0s |
| Unconfigured Alarm Destination | NNC1 | WRN | | <input type="checkbox"/> | <input type="checkbox"/> | <input type="checkbox"/> | <input type="checkbox"/> | <input type="checkbox"/> | <input type="checkbox"/> | <input type="checkbox"/> | <input type="checkbox"/> | <input type="checkbox"/> | <input type="checkbox"/> | <input type="checkbox"/> | <input type="checkbox"/> | <input type="checkbox"/> | <input type="checkbox"/> | <input type="checkbox"/> | 0s |
| No Dial-Out Response | POR1 | WRN | | <input type="checkbox"/> | <input type="checkbox"/> | <input type="checkbox"/> | <input type="checkbox"/> | <input type="checkbox"/> | <input type="checkbox"/> | <input type="checkbox"/> | <input type="checkbox"/> | <input type="checkbox"/> | <input type="checkbox"/> | <input type="checkbox"/> | <input type="checkbox"/> | <input type="checkbox"/> | <input type="checkbox"/> | <input type="checkbox"/> | 0s |
| External Password Reset | EPR1 | WRN | | <input type="checkbox"/> | <input type="checkbox"/> | <input type="checkbox"/> | <input type="checkbox"/> | <input type="checkbox"/> | <input type="checkbox"/> | <input type="checkbox"/> | <input type="checkbox"/> | <input type="checkbox"/> | <input type="checkbox"/> | <input type="checkbox"/> | <input type="checkbox"/> | <input type="checkbox"/> | <input type="checkbox"/> | <input type="checkbox"/> | 0s |

35) PowerShift Alarms

Note: Changes can be made quickly by clicking on Sev button and Relay button; for example:

Click on the "Relay" column header and select "R1"; this will change all alarms to R1

For alarms with MAJ severity, change the relay to "R2"

| Power Shift Alarms | ID | Sev. | Relay | LED | EMAIL | | | | SNMP | | | | PHONE | | | | Delay | | |
|--|-------|------|-------|--------------------------|--------------------------|--------------------------|--------------------------|--------------------------|--------------------------|--------------------------|--------------------------|--------------------------|--------------------------|--------------------------|--------------------------|--------------------------|--------------------------|--------------------------|----|
| | | | | | 1 | 2 | 3 | 4 | 1 | 2 | 3 | 4 | 1 | 2 | 3 | 4 | | O | R |
| Incompatible PowerShift | ICLD1 | CRIT | R1 | <input type="checkbox"/> | <input type="checkbox"/> | <input type="checkbox"/> | <input type="checkbox"/> | <input type="checkbox"/> | <input type="checkbox"/> | <input type="checkbox"/> | <input type="checkbox"/> | <input type="checkbox"/> | <input type="checkbox"/> | <input type="checkbox"/> | <input type="checkbox"/> | <input type="checkbox"/> | <input type="checkbox"/> | <input type="checkbox"/> | 0s |
| OVP System H2O | TH2O1 | CRIT | R1 | <input type="checkbox"/> | <input type="checkbox"/> | <input type="checkbox"/> | <input type="checkbox"/> | <input type="checkbox"/> | <input type="checkbox"/> | <input type="checkbox"/> | <input type="checkbox"/> | <input type="checkbox"/> | <input type="checkbox"/> | <input type="checkbox"/> | <input type="checkbox"/> | <input type="checkbox"/> | <input type="checkbox"/> | <input type="checkbox"/> | 0s |
| OVP System Intrusion | TINT1 | CRIT | R1 | <input type="checkbox"/> | <input type="checkbox"/> | <input type="checkbox"/> | <input type="checkbox"/> | <input type="checkbox"/> | <input type="checkbox"/> | <input type="checkbox"/> | <input type="checkbox"/> | <input type="checkbox"/> | <input type="checkbox"/> | <input type="checkbox"/> | <input type="checkbox"/> | <input type="checkbox"/> | <input type="checkbox"/> | <input type="checkbox"/> | 0s |
| OVP System Power | LTP1 | CRIT | R1 | <input type="checkbox"/> | <input type="checkbox"/> | <input type="checkbox"/> | <input type="checkbox"/> | <input type="checkbox"/> | <input type="checkbox"/> | <input type="checkbox"/> | <input type="checkbox"/> | <input type="checkbox"/> | <input type="checkbox"/> | <input type="checkbox"/> | <input type="checkbox"/> | <input type="checkbox"/> | <input type="checkbox"/> | <input type="checkbox"/> | 0s |
| OVP Upper Voltage Out of Range | LUV1 | CRIT | R1 | <input type="checkbox"/> | <input type="checkbox"/> | <input type="checkbox"/> | <input type="checkbox"/> | <input type="checkbox"/> | <input type="checkbox"/> | <input type="checkbox"/> | <input type="checkbox"/> | <input type="checkbox"/> | <input type="checkbox"/> | <input type="checkbox"/> | <input type="checkbox"/> | <input type="checkbox"/> | <input type="checkbox"/> | <input type="checkbox"/> | 0s |
| OVP Upper to Lower Comm | TBC1 | CRIT | R1 | <input type="checkbox"/> | <input type="checkbox"/> | <input type="checkbox"/> | <input type="checkbox"/> | <input type="checkbox"/> | <input type="checkbox"/> | <input type="checkbox"/> | <input type="checkbox"/> | <input type="checkbox"/> | <input type="checkbox"/> | <input type="checkbox"/> | <input type="checkbox"/> | <input type="checkbox"/> | <input type="checkbox"/> | <input type="checkbox"/> | 0s |
| PowerShift AutoResistance Fail | ARF1 | MAJ | R2 | <input type="checkbox"/> | <input type="checkbox"/> | <input type="checkbox"/> | <input type="checkbox"/> | <input type="checkbox"/> | <input type="checkbox"/> | <input type="checkbox"/> | <input type="checkbox"/> | <input type="checkbox"/> | <input type="checkbox"/> | <input type="checkbox"/> | <input type="checkbox"/> | <input type="checkbox"/> | <input type="checkbox"/> | <input type="checkbox"/> | 0s |
| PowerShift Boost Over Temp | RCO1 | CRIT | R1 | <input type="checkbox"/> | <input type="checkbox"/> | <input type="checkbox"/> | <input type="checkbox"/> | <input type="checkbox"/> | <input type="checkbox"/> | <input type="checkbox"/> | <input type="checkbox"/> | <input type="checkbox"/> | <input type="checkbox"/> | <input type="checkbox"/> | <input type="checkbox"/> | <input type="checkbox"/> | <input type="checkbox"/> | <input type="checkbox"/> | 0s |
| PowerShift Fuse Fail | RFF1 | CRIT | R1 | <input type="checkbox"/> | <input type="checkbox"/> | <input type="checkbox"/> | <input type="checkbox"/> | <input type="checkbox"/> | <input type="checkbox"/> | <input type="checkbox"/> | <input type="checkbox"/> | <input type="checkbox"/> | <input type="checkbox"/> | <input type="checkbox"/> | <input type="checkbox"/> | <input type="checkbox"/> | <input type="checkbox"/> | <input type="checkbox"/> | 0s |
| PowerShift ID Conflict | RRID1 | MAJ | R2 | <input type="checkbox"/> | <input type="checkbox"/> | <input type="checkbox"/> | <input type="checkbox"/> | <input type="checkbox"/> | <input type="checkbox"/> | <input type="checkbox"/> | <input type="checkbox"/> | <input type="checkbox"/> | <input type="checkbox"/> | <input type="checkbox"/> | <input type="checkbox"/> | <input type="checkbox"/> | <input type="checkbox"/> | <input type="checkbox"/> | 0s |
| PowerShift Input Fail | RIP1 | CRIT | R1 | <input type="checkbox"/> | <input type="checkbox"/> | <input type="checkbox"/> | <input type="checkbox"/> | <input type="checkbox"/> | <input type="checkbox"/> | <input type="checkbox"/> | <input type="checkbox"/> | <input type="checkbox"/> | <input type="checkbox"/> | <input type="checkbox"/> | <input type="checkbox"/> | <input type="checkbox"/> | <input type="checkbox"/> | <input type="checkbox"/> | 0s |
| PowerShift Interlock Open | RIO1 | CRIT | R1 | <input type="checkbox"/> | <input type="checkbox"/> | <input type="checkbox"/> | <input type="checkbox"/> | <input type="checkbox"/> | <input type="checkbox"/> | <input type="checkbox"/> | <input type="checkbox"/> | <input type="checkbox"/> | <input type="checkbox"/> | <input type="checkbox"/> | <input type="checkbox"/> | <input type="checkbox"/> | <input type="checkbox"/> | <input type="checkbox"/> | 0s |
| PowerShift Module Over Temp | RMT1 | CRIT | R1 | <input type="checkbox"/> | <input type="checkbox"/> | <input type="checkbox"/> | <input type="checkbox"/> | <input type="checkbox"/> | <input type="checkbox"/> | <input type="checkbox"/> | <input type="checkbox"/> | <input type="checkbox"/> | <input type="checkbox"/> | <input type="checkbox"/> | <input type="checkbox"/> | <input type="checkbox"/> | <input type="checkbox"/> | <input type="checkbox"/> | 0s |
| PowerShift Multiple Fan Fail | RMF1 | CRIT | R1 | <input type="checkbox"/> | <input type="checkbox"/> | <input type="checkbox"/> | <input type="checkbox"/> | <input type="checkbox"/> | <input type="checkbox"/> | <input type="checkbox"/> | <input type="checkbox"/> | <input type="checkbox"/> | <input type="checkbox"/> | <input type="checkbox"/> | <input type="checkbox"/> | <input type="checkbox"/> | <input type="checkbox"/> | <input type="checkbox"/> | 0s |
| PowerShift Output V Out of Rng | ROV1 | MAJ | R2 | <input type="checkbox"/> | <input type="checkbox"/> | <input type="checkbox"/> | <input type="checkbox"/> | <input type="checkbox"/> | <input type="checkbox"/> | <input type="checkbox"/> | <input type="checkbox"/> | <input type="checkbox"/> | <input type="checkbox"/> | <input type="checkbox"/> | <input type="checkbox"/> | <input type="checkbox"/> | <input type="checkbox"/> | <input type="checkbox"/> | 0s |
| PowerShift Overload | ROL1 | CRIT | R1 | <input type="checkbox"/> | <input type="checkbox"/> | <input type="checkbox"/> | <input type="checkbox"/> | <input type="checkbox"/> | <input type="checkbox"/> | <input type="checkbox"/> | <input type="checkbox"/> | <input type="checkbox"/> | <input type="checkbox"/> | <input type="checkbox"/> | <input type="checkbox"/> | <input type="checkbox"/> | <input type="checkbox"/> | <input type="checkbox"/> | 0s |
| PowerShift Primary Fault | LPRI1 | CRIT | R1 | <input type="checkbox"/> | <input type="checkbox"/> | <input type="checkbox"/> | <input type="checkbox"/> | <input type="checkbox"/> | <input type="checkbox"/> | <input type="checkbox"/> | <input type="checkbox"/> | <input type="checkbox"/> | <input type="checkbox"/> | <input type="checkbox"/> | <input type="checkbox"/> | <input type="checkbox"/> | <input type="checkbox"/> | <input type="checkbox"/> | 0s |
| PowerShift Redundancy Loss | LRLS1 | MAJ | R2 | <input type="checkbox"/> | <input type="checkbox"/> | <input type="checkbox"/> | <input type="checkbox"/> | <input type="checkbox"/> | <input type="checkbox"/> | <input type="checkbox"/> | <input type="checkbox"/> | <input type="checkbox"/> | <input type="checkbox"/> | <input type="checkbox"/> | <input type="checkbox"/> | <input type="checkbox"/> | <input type="checkbox"/> | <input type="checkbox"/> | 0s |
| PowerShift Resistance | LRES1 | CRIT | R1 | <input type="checkbox"/> | <input type="checkbox"/> | <input type="checkbox"/> | <input type="checkbox"/> | <input type="checkbox"/> | <input type="checkbox"/> | <input type="checkbox"/> | <input type="checkbox"/> | <input type="checkbox"/> | <input type="checkbox"/> | <input type="checkbox"/> | <input type="checkbox"/> | <input type="checkbox"/> | <input type="checkbox"/> | <input type="checkbox"/> | 0s |
| PowerShift Single Fan Fail | RSF1 | CRIT | R1 | <input type="checkbox"/> | <input type="checkbox"/> | <input type="checkbox"/> | <input type="checkbox"/> | <input type="checkbox"/> | <input type="checkbox"/> | <input type="checkbox"/> | <input type="checkbox"/> | <input type="checkbox"/> | <input type="checkbox"/> | <input type="checkbox"/> | <input type="checkbox"/> | <input type="checkbox"/> | <input type="checkbox"/> | <input type="checkbox"/> | 0s |
| PowerShift Translator Timeout | TPT1 | CRIT | R1 | <input type="checkbox"/> | <input type="checkbox"/> | <input type="checkbox"/> | <input type="checkbox"/> | <input type="checkbox"/> | <input type="checkbox"/> | <input type="checkbox"/> | <input type="checkbox"/> | <input type="checkbox"/> | <input type="checkbox"/> | <input type="checkbox"/> | <input type="checkbox"/> | <input type="checkbox"/> | <input type="checkbox"/> | <input type="checkbox"/> | 0s |
| PowerShift Upper Voltage Low | PUVL1 | MAJ | R2 | <input type="checkbox"/> | <input type="checkbox"/> | <input type="checkbox"/> | <input type="checkbox"/> | <input type="checkbox"/> | <input type="checkbox"/> | <input type="checkbox"/> | <input type="checkbox"/> | <input type="checkbox"/> | <input type="checkbox"/> | <input type="checkbox"/> | <input type="checkbox"/> | <input type="checkbox"/> | <input type="checkbox"/> | <input type="checkbox"/> | 0s |
| PowerShift Voltage Not Linked | LVNL1 | CRIT | R1 | <input type="checkbox"/> | <input type="checkbox"/> | <input type="checkbox"/> | <input type="checkbox"/> | <input type="checkbox"/> | <input type="checkbox"/> | <input type="checkbox"/> | <input type="checkbox"/> | <input type="checkbox"/> | <input type="checkbox"/> | <input type="checkbox"/> | <input type="checkbox"/> | <input type="checkbox"/> | <input type="checkbox"/> | <input type="checkbox"/> | 0s |

Click "Relay" button to assign all to "R1", then click the alarms with "MAJ" and change to "R2"

Section 12: Closeout Package

Once the installation is complete and all alarms are cleared, use the following procedure to capture information for inclusion in the site installation closeout package

Capture the Circuit Map Worksheet

- Fill out the Circuit Map Worksheet (located on page 9)
- Obtain a photo of the completed worksheet and save it as a jpg file to your Windows PC

Capture Alarm History Report

- In the GUI, click the Maintenance tab and clear the alarm history using the "clear alarm" button (the pull-down list underneath it should be set to "Alarm")
- Click the Reports tab, then click the Alarm History hotlink
- Click the Print Event History button to generate a pdf file, save it to your Windows PC

Capture Inventory Report

- In the GUI, click the Reports tab, then click the Inventory Report tab; it may take a minute for the report to generate
- To generate a pdf file, click the small printer icon in the upper right corner of the Inventory banner
- Important: Set the Layout to Landscape, save the pdf file to your Windows PC

Capture Home Page

- In the GUI, click on the Home tab
- Obtain a screen capture of the Home page, save it as a jpg file to your PC

Capture Circuit Pop-up Boxes

- In the GUI Home page, click on each boost module circuit to open the pop-up box
- Note that multiple pop-up boxes can be opened at the same time, they can be moved around on the page and resized as needed; this allows you to arrange at least four circuits on the page before obtaining a screen shot
- Obtain multiple screen shots as needed to capture all the boost module circuits, save them as jpg files to your Windows PC

Section 13: Troubleshooting Raycap Issues

Raycap Displays Shows 0V (example using L1/U1)

L1 voltage is 0: If Circuit 01 on the PowerShift shelf has input power and it has output voltage, then there is a possible problem with the output cabling from the PowerShift shelf to the OVP base. For example, a cross-wiring mistake where the shelf Circuit 01 output cable is connected to the wrong terminals on the OVP base

U1 voltage is 0: If the L1 voltage is not 0V, then there is a possible problem with the trunk power cables or with the twisted-pair cables between the OVP base and OVP top. Press the Wake/Adv button on the OVP base to cycle through the other measurements (L2/U2, L3/U3, etc.) to confirm they all report 0 voltage; if any non-zero voltages are observed this probably indicates a cross-wiring problem

Raycap Base OVP Alarm Condition:

The Raycap OVP base has three LEDs that illuminate red in case of an error:

- Intrusion: The top OVP cover is removed (or the intrusion micro-switch could be bad)
- H2O: The top OVP has water or high moisture content
- Power: There are several possible alarm conditions, see below

The Raycap Voltage display and the Power Alarm LED may present as one of the three scenarios shown below

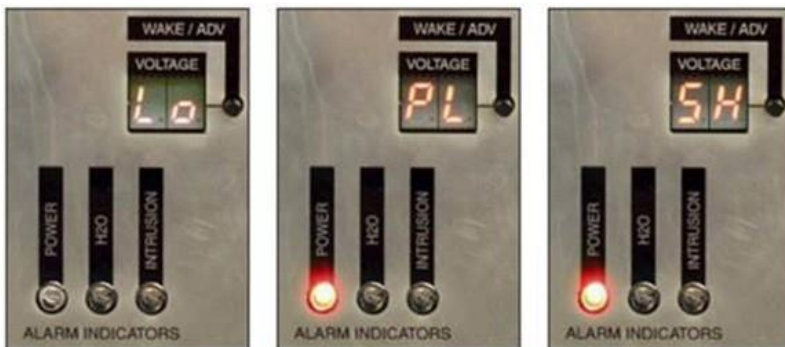

Low Voltage
(less than 35V)

Reverse Polarity

Short Circuit

General Description:

- “Lo” = Low voltage condition
(voltage at base or at top is <35V)
- “PL” = Polarity reversal condition
(the supply and return cables are swapped)
- “SH” = Short-circuit condition
(the supply and return cables are shorted together)

Following is a more detailed description of possible Power Alarm LED and Voltage display error conditions (using L1/U1 as an example):

| L1 (lower) | U1 (upper) | Power Alarm LED | Possible Cause |
|--------------|------------|-----------------|--|
| Lo | Lo | Off | This is the expected, nominal condition for a circuit that is fully cabled but is not powered (i.e. the circuit breaker is open, or PowerShift boost and bypass modules are both not installed, or PowerShift circuit output is disabled). Note that in this configuration there will be a 30-33V present on the circuit; it is a "sensing voltage" the Raycap OVP uses to confirm the status of an unpowered circuit. |
| Lo | Lo | On | Should only occur if the top OVP is a model 3315 (non-retrofit) and the sensing voltage is being dragged down to <24V (which is likely caused by an unexpected load current on the circuit). |
| Lo | 00 | - | Trunk cable pair is not connected between base and top OVPs. Or if top OVP is a model 3315 (non-retrofit) then voltmeter twisted-pair may be disconnected between base and top OVPs (see Note1 below). |
| Lo (or) >54V | PL | On | The trunk cable supply/return cables are swapped at the terminal block on the base OVP or on the top OVP. Or if the top OVP is a model 3315 (non-retrofit) then voltmeter twisted-pair may be swapped or disconnected (see Note1 below) |
| SH | SH | On | There is a short circuit between supply/return cables; could be located at base OVP terminals, top OVP terminals or somewhere within the trunk cable. |
| SH | 00 | On | Should only occur if top OVP is a model 3315; the circuit is shorted and the voltmeter twisted-pair may be disconnected between base and top OVP (see Note1 below). |
| >54V | Lo | Off | Should only occur if top OVP is a model 3315; the trunk supply cable may be disconnected (and the return cable is connected) |
| >54V | 00 | Off | Trunk cable pair is not connected to top OVP. Or if top OVP is a model 3315 (non-retrofit) then the trunk return cable may be disconnected (and the supply cable is connected), or the voltmeter twisted-pair may be shorted (see Note1 below). |

Note: Following is the location of the terminal blocks that connect the volt meter twisted-pair

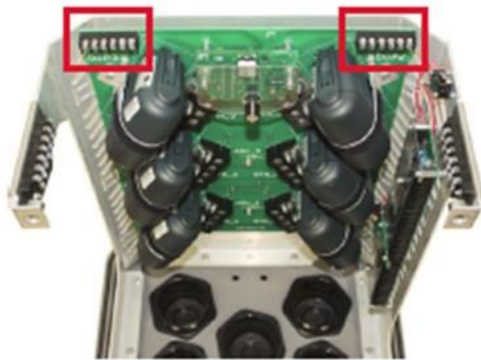

3315 OVP dome

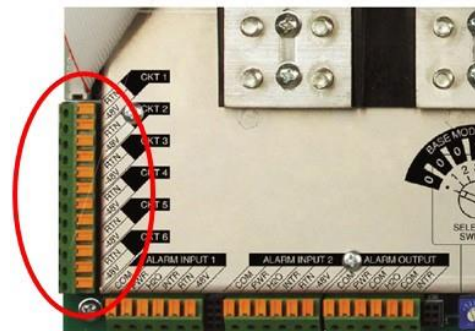

2260 Rackmount

Section 14: PowerShift Alarms and Troubleshooting

Boost and Bypass Module LEDs

There are four status indicators on each Boost module and Bypass Module: P-In, P-Out, S-In, S-Out:

- 1) P-In and P-Out represent the status of the input and output circuits (respectively) of the first circuit in a boost module or bypass module.
- 2) S-In and S-Out represent the status of the input and output circuits (respectively) of the second circuit in a boost module or bypass module.

The following table provides a summary of LED status and the corresponding operational status of the hardware.

Power and Bypass Module Operational State

| P-In LED | P-Out LED | S-In LED | S-Out LED | Condition |
|--------------|--------------|--------------|--------------|--|
| Off | Off | Off | Off | No Input Power |
| Yellow Solid | Red Blink | Yellow Solid | Red Blink | Initial Power On (~30 seconds duration) |
| Green Solid | Green Solid | Green Solid | Green Solid | Normal Operating State ¹ |
| Green Solid | Green Solid | Yellow Solid | Off | Input Power to Only One Circuit ² (e.g. no power to second circuit) |
| Green Solid | Yellow Solid | Green Solid | Yellow Solid | Bypass Module Active ³ |
| Green Solid | Yellow Blink | Green Solid | Yellow Blink | Short-Circuit or Overload On Output Circuit |
| Yellow Solid | Off | Yellow Solid | Off | Input Voltage Out of Range (<38VDC or >58VDC) |
| Green Solid | Red Blink | Green Solid | Red Blink | Circuit is Over-Temperature (output power is disabled) |
| Green Solid | Green Blink | Green Solid | Green Blink | Circuit was Over-Temperature but has recovered (output power is enabled) |

¹ Normal operating state for the Boost module and Bypass module

² If only one module circuit has input power, the other circuit will show yellow solid on the Input LED for (boost and bypass modules); the alarm condition can be cleared by disabling the unpowered circuit in the GUI

³ If a boost module circuit has failed or if the boost module has been removed from the shelf, the bypass module will show green solid on the input LED and yellow solid on the output LED

The following information provides additional details and troubleshooting guidelines on the LED status

Green

Boost module:

- 1) A solid green status light indicates the circuit is functioning properly

Bypass Module:

- 1) A solid green status light indicates the circuit is ready to provide bypass power, but the circuit is not currently in a bypass state

Yellow

Boost module:

- 1) A solid yellow status light on P-In or S-In indicates the circuit has no input power; this occurs when one circuit has input power but the other circuit does not.

Bypass Module:

- 1) A solid yellow status light on the output LED indicates the bypass circuit is active; the circuit is in bypass because the corresponding boost module circuit has failed or because the boost module has been removed from the shelf
 - a) The circuit has no input power; this occurs when one circuit has input power but the other circuit does not
 - b) The circuit input voltage is below minimum threshold (<38VDC)

Boost module or Bypass Module:

- 1) A winking yellow status light on P-Out or S-Out indicates a fault external to the module. The indicated circuit is not powered; the external fault maybe caused by the following:
 - a) Input voltage out of range, either < 38VDC or > 58 VDC; check output voltage at DC plant rectifier.
 - b) Short-circuit on the output cables, short-circuit or over-load condition at the RRU; the affected circuit will likely show solid green on the input and yellow wink on the output
- 2) Loss of thermal control of the enclosure. Unit is operating, but it has experienced a thermal event
 - a) Yellow may indicate a minor alarm that does not require immediate attention, but can be corrected in a service window. One example is the failure of one of the two fans in the module. The module will run, but should be replaced at earliest convenience.
- 3) After correcting the fault, the circuit can be returned to normal operation by toggling the DC plant breaker for that circuit

Red

Boost module or Bypass Module

- 1) A red winking status light on P-Out or S-Out indicates the module is unable to communicate with the Controller; this occurs:
 - a) During initial application of input power to the circuit (LED should change to solid green after 10-30 seconds)
 - b) Whenever the controller is inserted into its slot or if it reboots (LED should change to solid green after 10-30 seconds)
 - c) The circuit input voltage is above the maximum threshold (>58VDC)

GUI Alarms

The following table lists all of the PowerShift alarms generated in the GUI; active alarms are viewable in the GUI Home page, and the Reports tab provides an Alarm History report.

| GUI Alarm Description | Alarm Type | Severity | Relay # | Description [Troubleshooting] |
|---------------------------------|------------|-----------|---------|---|
| High Ambient Temperature | System | Major | 2 | Shelter/cabinet air temperature is above acceptable range |
| Low Ambient Temperature | System | Major | 2 | Shelter/cabinet air temperature is below acceptable range |
| Config Reboot Required | System | Critical | 1 | "Controller must be rebooted due to a configuration change [Reboost using GUI or reseal the controller to power cycle it]" |
| Auxiliary Major | System | Critical | 1 | N/A for PowerShift |
| Alarm Test Active | System | Read Only | | Indicates user has initiated test of the alarm relays. True while test is active |
| Alarm Test Aborted | System | Read Only | | User alarm test was aborted due to an actual alarm condition |
| Real Time Clock Battery Low | System | Warning | | The lithium battery in the controller RTC should be replaced |
| Configuration Changed | System | Read Only | | User has changed the system configuration |
| Clock Changed | System | Read Only | | User has changed the system time/date |
| ID Conflict | System | Critical | 1 | Indicates a problem with one or more boost or bypass modules |
| Excessive Login Attempts | System | Warning | | User has tried to login with an invalid password - three failed attempts |
| History Cleared | System | Read Only | | User has cleared history logs for alarm history or other history logs |
| Password At Default | System | Read Only | | The login passwords are at factory default |
| Processor Halt | System | Read Only | | The controller processor has stopped; controller was unseated in the shelf or power is otherwise removed from the controller. Entry is written during boot up based on RTC flag |
| Self Test Failed | System | Major | 2 | N/A for PowerShift |
| ID Not Configured | System | Critical | 1 | Boost or bypass module has an ID that is outside valid range |
| Minor Communication Fail Alarm | Comms | Major | 2 | Controller has lost communication with one boost or one bypass module |
| Queue Overflow | Comms | Warning | | N/A for PowerShift; applies only when a modem is used |
| No Call-Out Response | Comms | Warning | | N/A for PowerShift; applies only when a modem is used |
| Major Communication Fail Alarm | Comms | Critical | 1 | Controller has lost communication with multiple boost/bypass modules |
| Unconfigured Alarm Destination | Comms | Warning | | Alarm is configured to alert via dial-out or SNMP, but no destination has been defined |
| No Dial-Out Response | Comms | Warning | | N/A for PowerShift; applies only when a modem is used |
| External Password Reset | Comms | Warning | | N/A for PowerShift |
| Incompatible PowerShift | PowerShift | Critical | 1 | The controller has detected PowerShift V1 boost modules installed in the shelf; only V2 modules may be used with PowerShift V2 shelf |
| OVP System H2O | PowerShift | Critical | 1 | OVP alarm due to water ingress sensor activating on OVP dome unit |
| OVP System Intrusion | PowerShift | Critical | 1 | OVP alarm due to dome unit cover having been loosened or removed |
| OVP System Power | PowerShift | Critical | 1 | OVP alarm due to a power issue on one or more circuits |
| OVP Upper Voltage Out of Range | PowerShift | Critical | 1 | The reported radio input voltage is outside expected range (37V to 60V) |
| OVP Upper to Lower Comm | PowerShift | Critical | 1 | The OVP is reporting loss of communication between base unit and tower top unit(s) |
| PowerShift Auto Resistance Fail | PowerShift | Major | 2 | PowerShift was unable to complete a line resistance calculation for a circuit |
| PowerShift Boost Over Temp | PowerShift | Critical | 1 | "The PowerShift boost/bypass module has exceeded its operating temperature [Check for failed fan alarm on module; check the shelter or cabinet cooling system]" |
| PowerShift Fuse Fail | PowerShift | Critical | 1 | The PowerShift boost converter module has a failed internal fuse; replace the module |
| PowerShift ID Conflict | PowerShift | Major | 2 | Possible issue with the PowerShift shelf unit |
| PowerShift Input Fail | PowerShift | Critical | 1 | PowerShift has lost input power to a circuit; the circuit previously had input power applied and a boost/bypass module was installed for the circuit |
| PowerShift Interlock Open | PowerShift | Critical | 1 | "Boost or bypass module is improperly seated in the shelf, or the module backplane is damaged, or the shelf backplane is damaged [Reseat modules; inspect backplane of modules for any obvious damage]" |

Cont.

| GUI Alarm Description | Alarm Type | Severity | Relay # | Description [Troubleshooting] |
|--------------------------------|------------|----------|---------|---|
| PowerShift Module Over Temp | PowerShift | Critical | 1 | "The air inlet temperature to the module is above threshold temperature setpoint [Check shelter or cabinet cooling system]" |
| PowerShift Multiple Fan Fail | PowerShift | Critical | 1 | Both fans in a PowerShift boost or bypass module have failed; replace the module |
| PowerShift Output V Out of Rng | PowerShift | Major | 2 | "PowerShift boost module output voltage has exceeded the maximum output voltage of 73V [Should not occur unless module is faulted; replace the module]" |
| PowerShift Overload | PowerShift | Critical | 1 | "The output current on a PowerShift circuit has exceeded the specified maximum value of 30A, the module has turned off its output; if circuit over-current condition clears within 20 minutes, then module will re-enable output [Check for short-circuit on cable or radio; check for radio drawing excessive current]" |
| PowerShift Primary Fault | PowerShift | Critical | 1 | "A boost and bypass module pair are simultaneously trying to supply load current to a circuit [Unseat bypass module then reset, if problem persists then swap in a different boost or bypass module to determine which module is faulted]" |
| PowerShift Redundancy Loss | PowerShift | Critical | 1 | One or more PowerShift circuits has lost redundant backup power on a circuit; this can be due failure of a boost or bypass module, removal of a boost or bypass module for maintenance purposes, etc. |
| PowerShift Resistance | PowerShift | Critical | 1 | The line resistance calculated by PowerShift has a value exceeding 1 Ohms; this indicates a problem condition with the line or misapplication of the product |
| PowerShift Single Fan Fail | PowerShift | Major | 2 | One fan in a PowerShift boost or bypass module has failed; replace the module |
| PowerShift Translator Timeout | PowerShift | Critical | 1 | "Communication failure between PowerShift shelf and OVP base unit [Check RS485 cable connection from OVP Boost Output port to PowerShift shelf R1 port]" |
| PowerShift Upper Voltage Low | PowerShift | Major | 2 | The reported radio input voltage is lower than the minimum expected voltage of 37V |
| PowerShift Voltage Not Linked | PowerShift | Critical | 1 | A PowerShift circuit has input power applied and its output power is enabled, but the GUI has not been configured to link an OVP voltage measurement to the circuit |

PowerShift Output Overload Protection

The boost module is designed to shut off its output circuit in the event the load demand exceeds the circuit maximum output capacity of 2000W total power (radio demand + power loss in the trunk cable)

Under normal circumstance an output overload should not occur; the proper design and installation of the PowerShift system ensures the maximum radio load demand and the trunk cable length do not exceed the circuit capacity.

However, off-nominal events such as a short in the trunk cable or a malfunctioning radio could cause the load demand to exceed the module output capacity. In this event the module functions as follows:

When circuit capacity is exceeded the module will shut off its output

The module then checks the condition of the circuit periodically (about every 5 seconds) to determine if the overload condition remains or if it has cleared

If the overload condition clears, the module will re-enable output on the circuit

If the overload condition has not cleared, the module will continue to keep the circuit output shut off and will continue to check the circuit condition about every 5 seconds

After 20 minutes, if the circuit overload condition has not cleared, the module will latch the circuit output off and will discontinue checking the circuit condition

Once the circuit is latched off, the user must intervene to re-enable it; the overload condition must be cleared and the circuit can then be re-enabled by cycling the input power breaker or by using the GUI to disable/enable the circuit

Section 15: Alarm/GP/RS485 Connectors

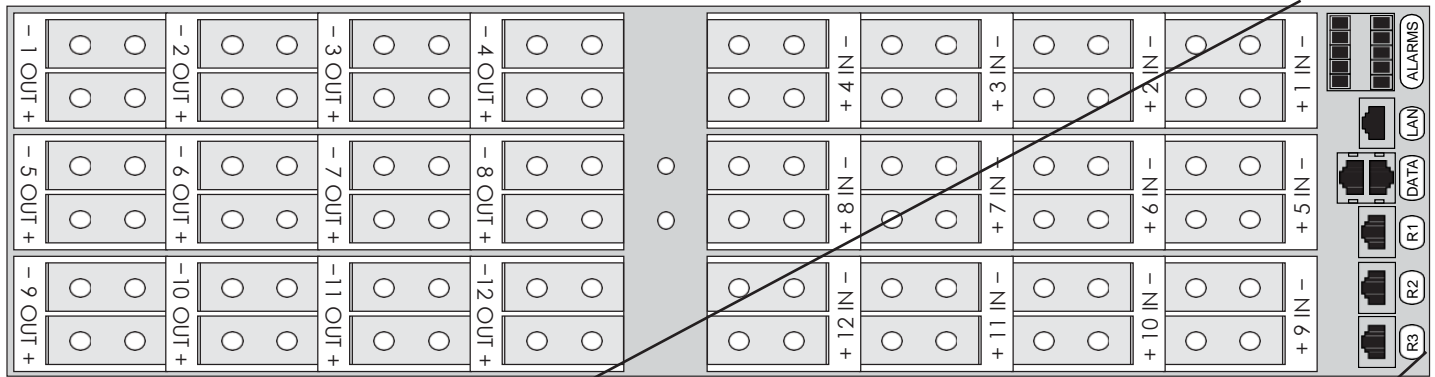

Office alarm connector

Relationship between office alarms and LAN stays the same for maximum resue

Ethernet

Daisy chained GP connectors

Allows integration into larger system controllers

RS485 connector (R1)

Connection to Raycap

R2/R3

Not Used

CommScope

1100 CommScope Place SE P.O. Box 339, Hickory, NC 28603-0339
 (828) 324-2200 (800) 982-1708
www.commscope.com

Customer Service 24 hours

North America: +1-800-255-1479 (toll free)
 Any country: +1-779-435-6500
 email: acicustomersupportcenter@commscope.com

Notice: CommScope disclaims any liability or responsibility for the results of improper or unsafe installation, inspection, maintenance, or removal practices.
 Aviso: CommScope no acepta ninguna obligación ni responsabilidad como resultado de prácticas incorrectas o peligrosas de instalación, inspección, mantenimiento o retiro.
 Avis: CommScope décline toute responsabilité pour les conséquences de procédures d'installation, d'inspection, d'entretien ou de retrait incorrectes ou dangereuses.
 Hinweis: CommScope lehnt jede Haftung oder Verantwortung für Schäden ab, die aufgrund unsachgemäßer Installation, Überprüfung, Wartung oder Demontage auftreten.
 Atenção: A CommScope abdica do direito de toda responsabilidade pelos resultados de práticas inadequadas e sem segurança de instalação, inspeção, manutenção ou remoção.
 Avvertenza: CommScope declina eventuali responsabilità derivanti dall'esecuzione di procedure di installazione, ispezione, manutenzione e smontaggio improprie o poco sicure.
 注意: CommScope 公司申明對於不恰當或不安全的安裝、檢驗、維修或拆卸操作所導致的後果不負責任 何義務和責任