

- 1.0 GENERAL NOTES
- 1.1 ALL METRIC DIMENSIONS ARE IN BRACKETS
- 1.2 FEATURES CRITICAL TO QUALITY ARE INDICATED IN ROUNDED BOX (XX)
- 2.0 DESIGN NOTES
- 3.0 MANUFACTURING/SPECIAL REQUIREMENTS
- 4.0 TEST
- 5.0 PACKAGING

REVISIONS			
REV.	DESCRIPTION	DATE	APPROVED
A	INITIAL RELEASE	ZL1057 15JUL22	ZM1026 40152305CMO
B	UPDATED VIEWS FOR MTM1161-1100,MTM1161-1200, MTM1161-1300,	ZL1057 28OCT22	ZM1026 40152305CMO

EQUIPMENT INSTALLATION CONFIGURATION LIST

CONFIGURATION	SHEET NO.	EQUIP.1	QTY	EQUIP.2	QTY	EQUIP.3	QTY	EQUIP.4	QTY	EQUIP.5	QTY
C1	5	AHFIB 320W	1	AHLBBA	1	DELTA 2.0KW RECTIFIER "ESR-4838A"	2	SDX1926Q-43 + RAYCAP	1		
C2	6	AHFIB 320W	1	AHLBBA	1	CCI PSU-1200W-48-N	2	SDX1926Q-43 + RAYCAP	1		
C3	7	AHLBBA	2	DELTA 2.0KW RECTIFIER "ESR-4838A"	2	SDX1926Q-43 + RAYCAP	1				
C4	8	AHLBBA	2	CCI PSU-1200W-48-N	2	SDX1926Q-43 + RAYCAP	1				
C8	9	AHFIB 320W	1	AHLBA	1	DELTA 2.0KW RECTIFIER "ESR-4838A"	2	SDX1926Q-43 + RAYCAP	1		
C9	10	AHFIB 320W	1	AHLBA	1	CCI PSU-1200W-48-N	2	SDX1926Q-43 + RAYCAP	1		
C11	11	AHFIB 320W	1	AHLBBA	1	DELTA 2.0KW RECTIFIER "ESR-4838A"	2	SDX1926Q-43 + RAYCAP	1	AZRB	1

EQUIPMENT INSTALLATION SEE SHEET2 AND SHEET3
HARDWARE INSTALLATION SEE SHEET4

COMMSCOPE, INC. OF NORTH CAROLINA											
TOLERANCES						SAP MATERIAL MASTER					
0 PLACE X[.X] ± N/A			2 PLACE .XX[.XXX] ±			7602532N-INSTALL					
1 PLACE .X[.XX] ±			ANGLES ±								
FINISH N/A						MATERIAL N/A					
760251532N-INSTALL											
UNLESS OTHERWISE SPECIFIED DIMENSIONS ARE IN MILLIMETERS INTERPRET PER ISO STANDARDS HANDBOOK TECHNICAL DRAWINGS VOLUMES 1 & 2, THIRD EDITION (2002)		NAME		DATE		760251532N-INSTALL					
		CE ZL1057		15JUL22							
		RW ZL1057		10/28/2022							
		AD ZM1026		11/01/2022							
		RE DM1121		11/01/2022							
ECN 40152305CMO						SCALE 1:20		DOCUMENT NO. 760251532N-INSTALL			
SIZE		Auth Group		INSL		MODEL		DRAWING		SHEET	
A2				VERSION		STATUS		REVISION		REVISION	
				02		RE		C		01	
HEIGHT		LENGTH		WIDTH		DENSITY		MASS		VOLUME	
						g/mm³		grams		mm³	
						mm²					

100

EQUIPMENT MOUNTING INSTALLATION

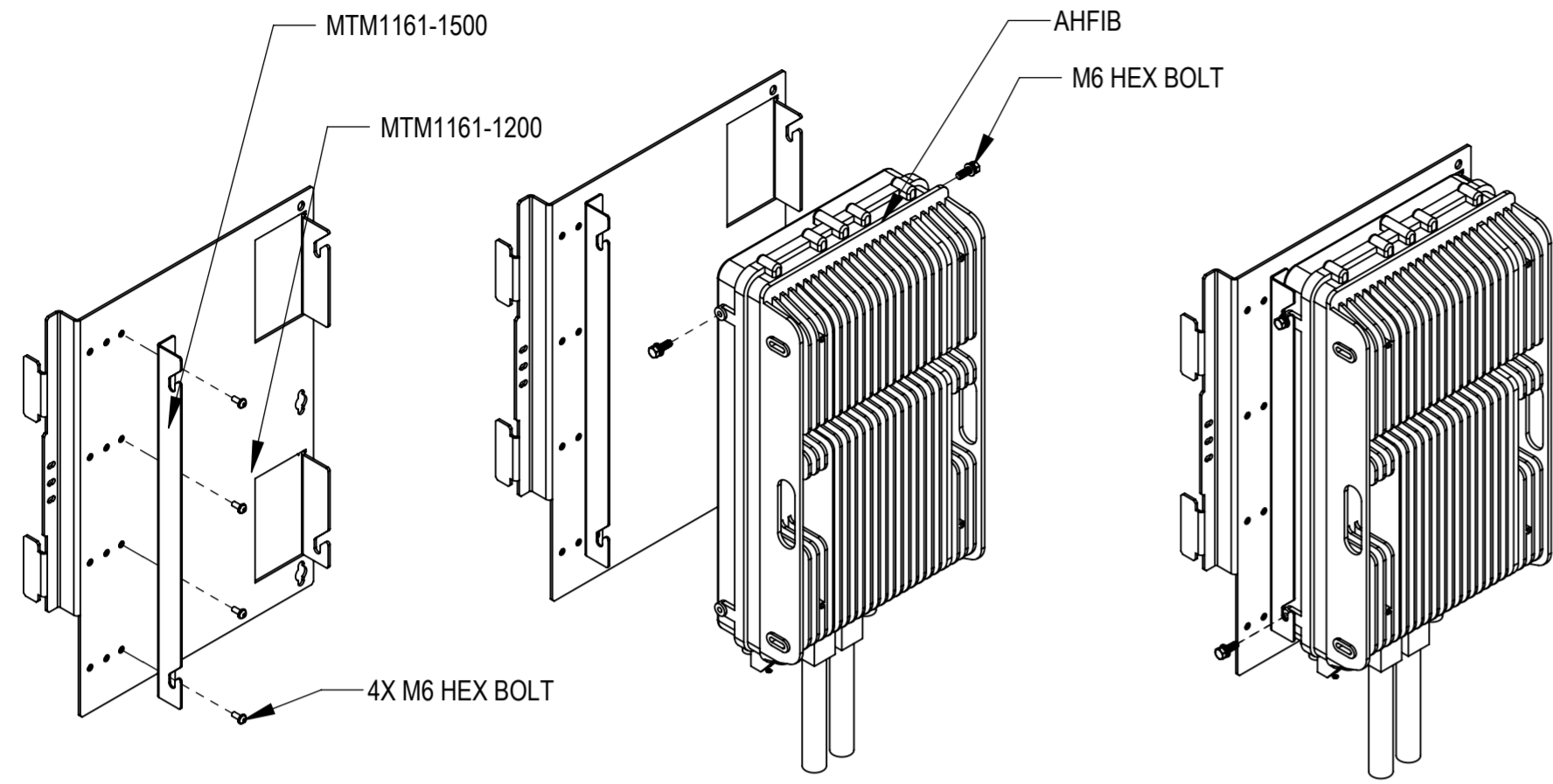

RIGHT AHFIB
 1. INSTALL MTM 1161-1500 TO THE BRACKET MTM1161-1200 USEING 4 SETS OF M6 HEX BOLT
 2. INSTALL THE AHFIB TO THE MOUNTING BRACKET MTM1161-1200 USING 4 SETS OF M6 HEX BOLT, FLAT WASHER AND LOCK WASHER AS SHOWN

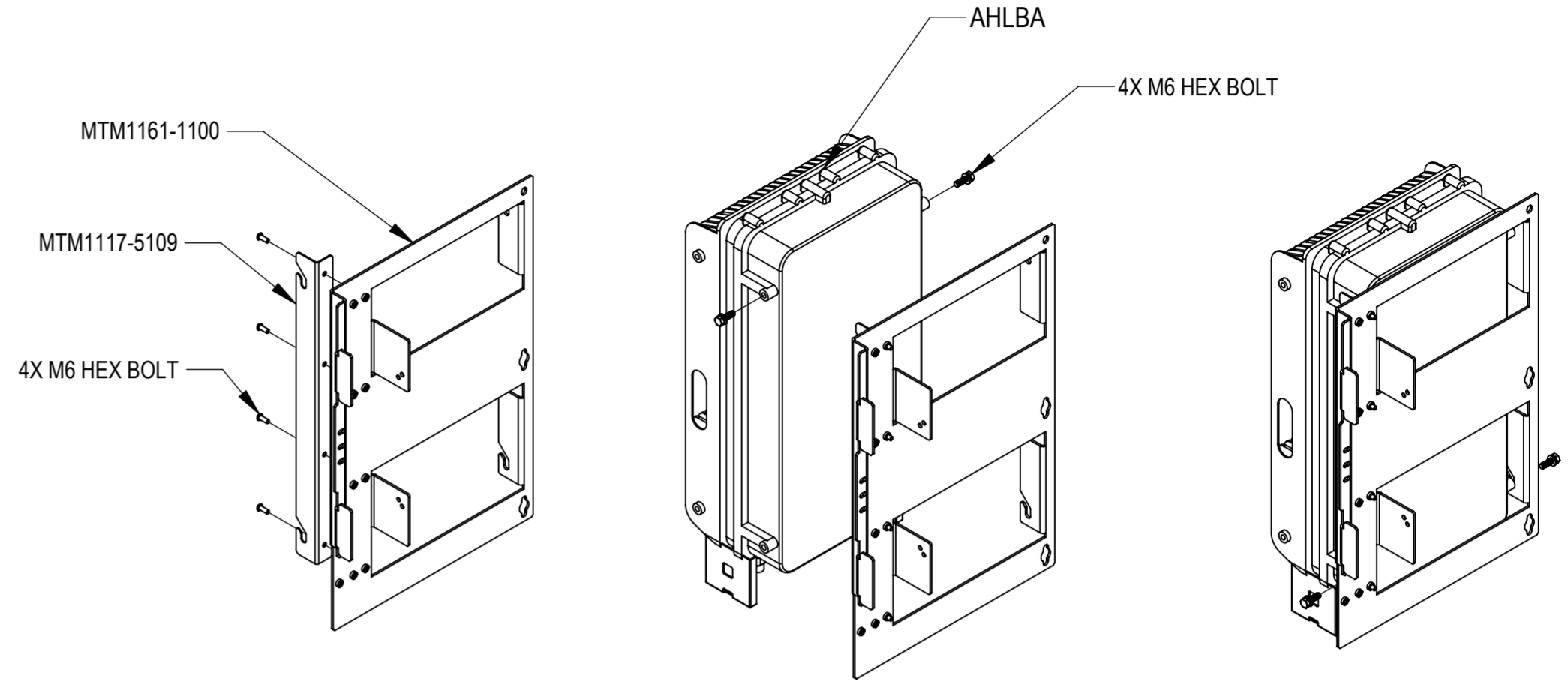

LEFT AHLBA
 1. INSTALL MTM1117-5109 TO THE BRACKET MTM1161-1100 USING 4 SETS OF M6 HEX BOLT
 2. INSTALL THE AHLBA TO THE MOUNTING BRACKET MTM1161-1100 USING 4 SETS OF M6 HEX BOLT, FLAT WASHER AND LOCK WASHER AS SHOWN

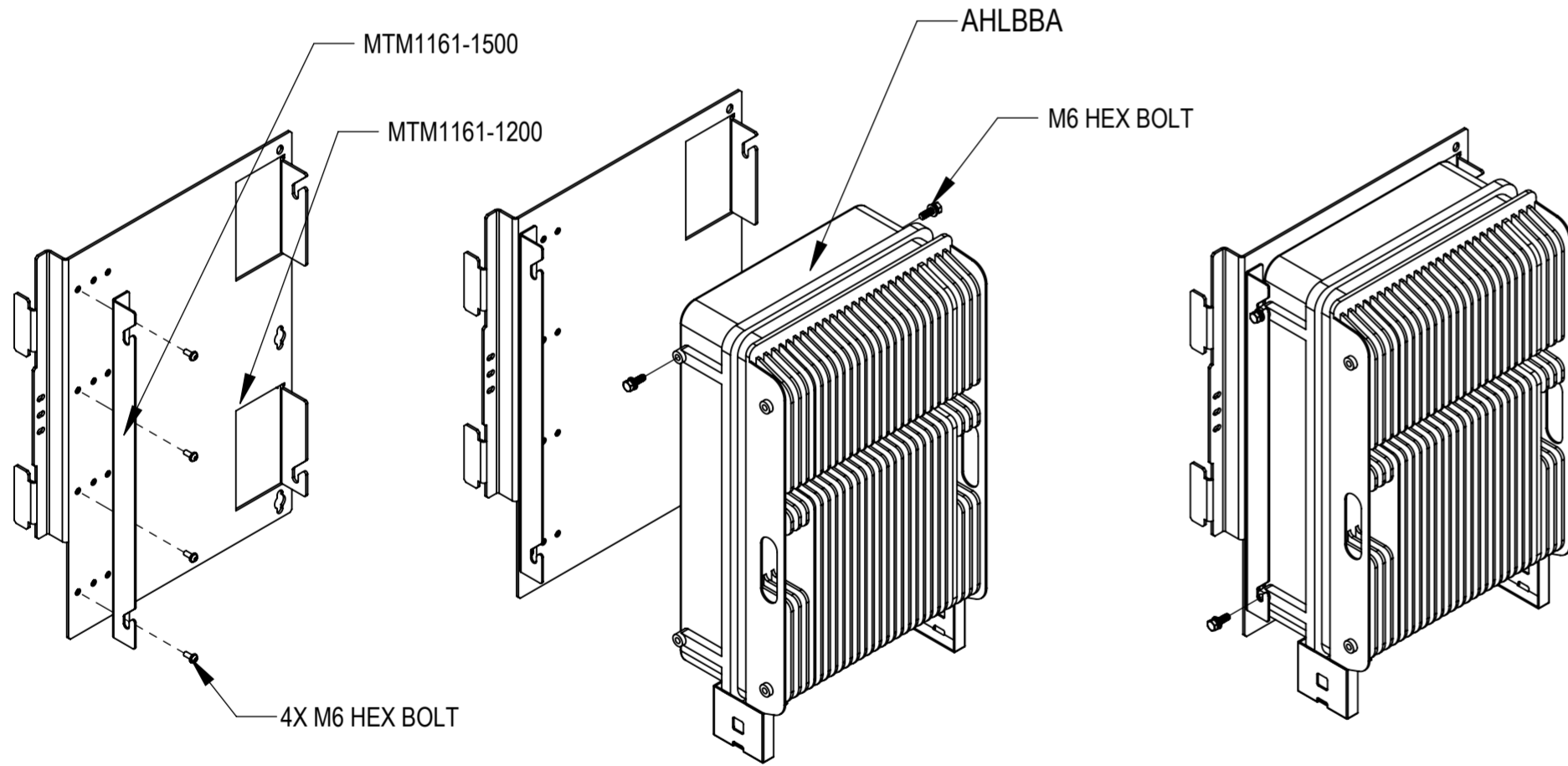

RIGHT AHLBBA
 1. INSTALL MTM 1161-1500 TO THE BRACKET MTM1161-1100 USEING 4 SETS OF M6 HEX BOLT
 2. INSTALL THE AHLBBA TO THE MOUNTING BRACKET MTM1161-1100 USING 4 SETS OF M6 HEX BOLT, FLAT WASHER AND LOCK WASHER AS SHOWN

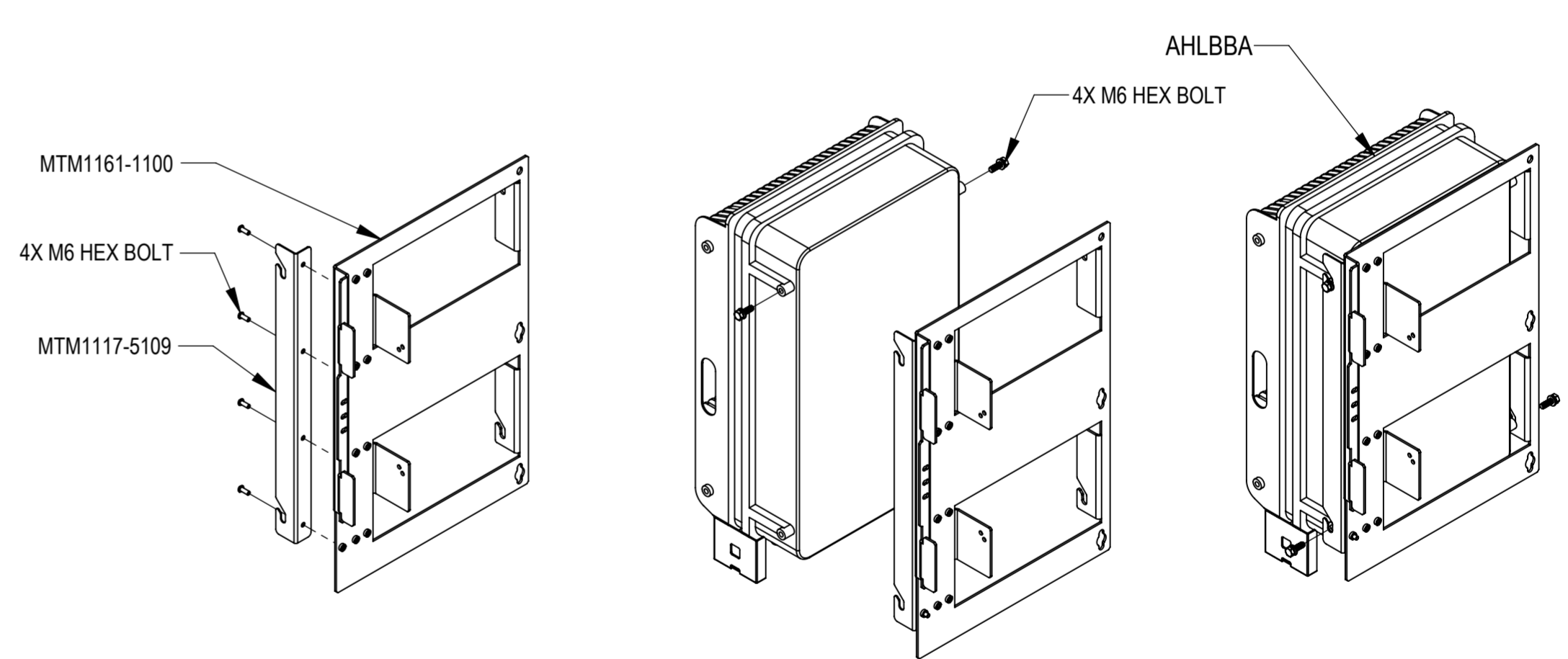

LEFT AHLBBA
 1. INSTALL MTM1117-5109 TO THE BRACKET MTM1161-1100 USEING 4 SETS OF M6 HEX BOLT
 2. INSTALL THE AHLBBA TO THE MOUNTING BRACKET MTM1161-1100 USING 4 SETS OF M6 HEX BOLT, FLAT WASHER AND LOCK WASHER AS SHOWN

COMMSCOPE, INC. OF NORTH CAROLINA				
TITLE				
760251532N-INSTALL				
SIZE	SCALE	DOCUMENT NO.		
A2	1:20	760251532N-INSTALL		
DRAWING				SHEET
VERSION	STATUS	REVISION	2 OF 11	
01	RE	B		

EQUIPMENT MOUNTING INSTALLATION

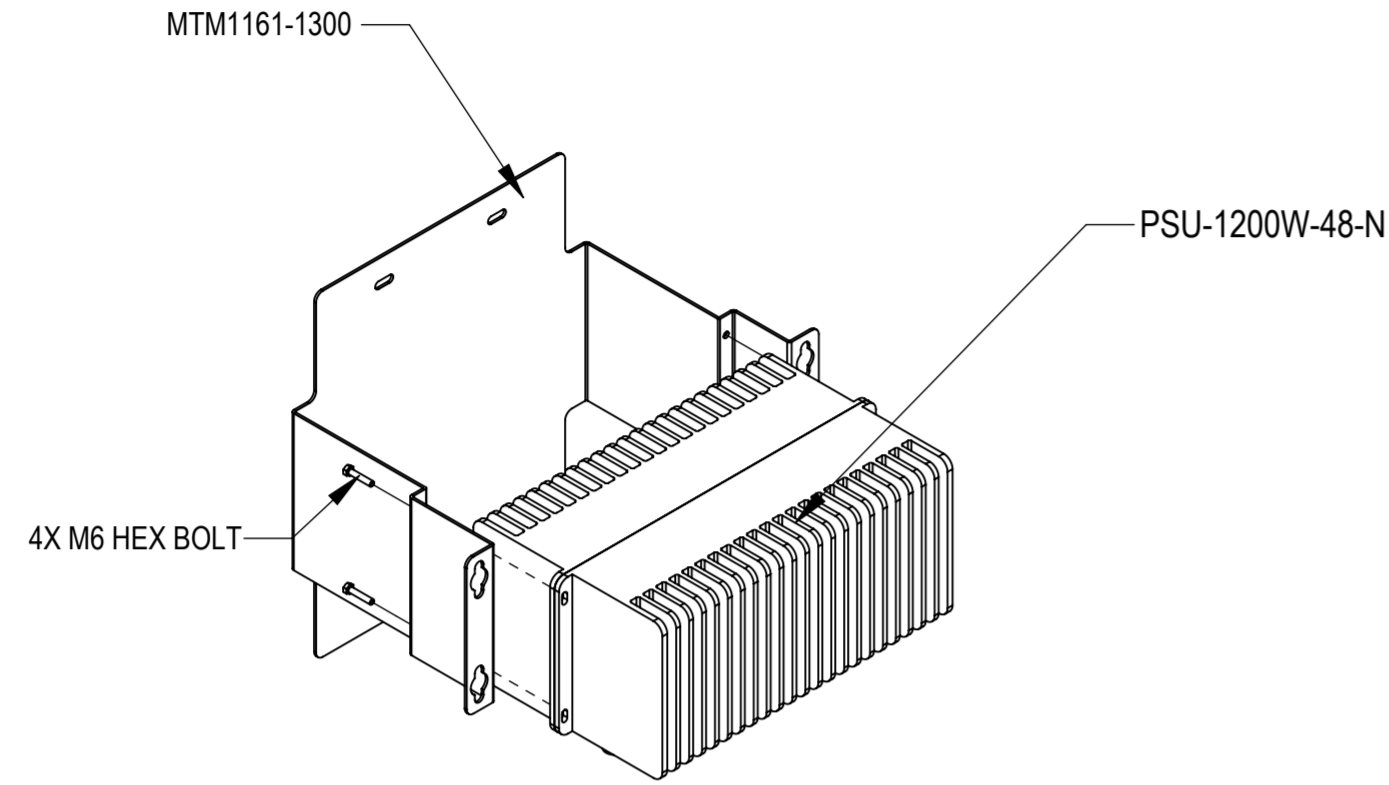

CCI PSU-1200W-48-N
 1. INSTALL THE SCCI PSU-1200W-48-N TO THE MOUNTING BRACKET MTM1161-1300 USING 4 SETS OF M6 HEX BOLT, FLAT WASHER AND LOCK WASHER AS SHOWN

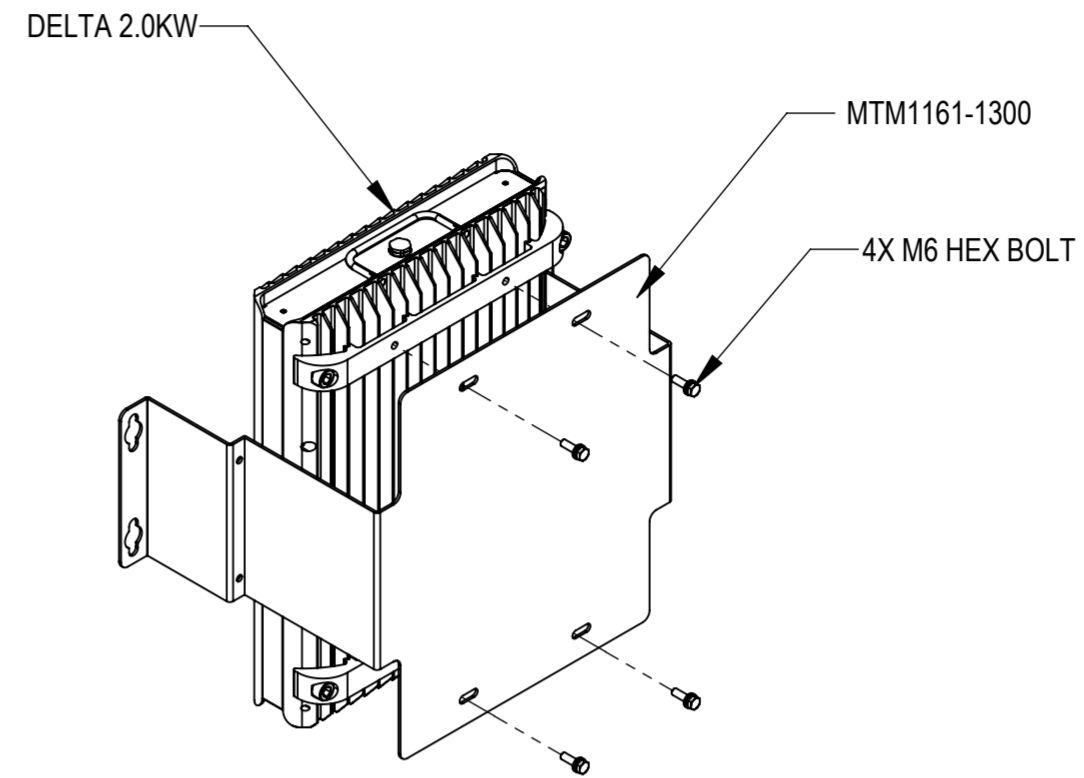

DELTA 2.0KW RECTIFIER "ESR-4838A"
 1. INSTALL THE DELTA 2.0KW RECTIFIER "ESR-4838A" TO THE MOUNTING BRACKET MTM1161-1300 USING 4 SETS OF M6 HEX BOLT, FLAT WASHER AND LOCK WASHER AS SHOWN

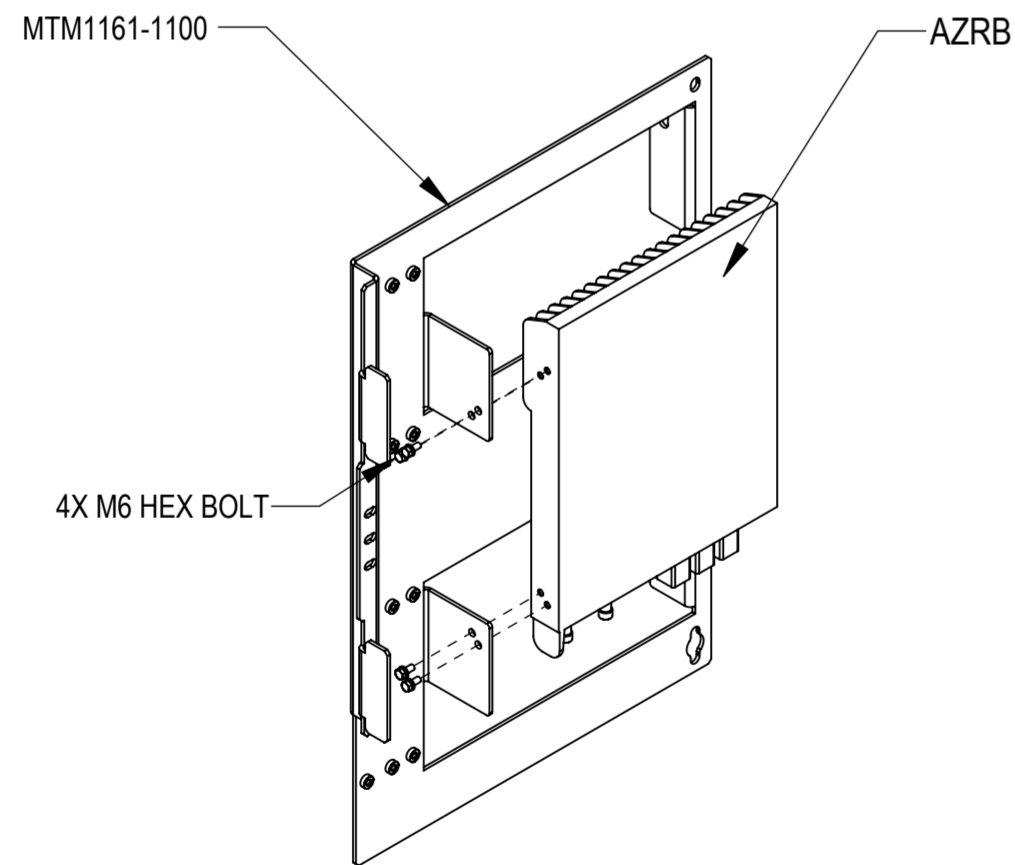

AZRB
 1. INSTALL THE AZRB TO THE MOUNTING BRACKET MTM1161-1100 USING 4 SETS OF M6 HEX BOLT, FLAT WASHER AND LOCK WASHER AS SHOWN

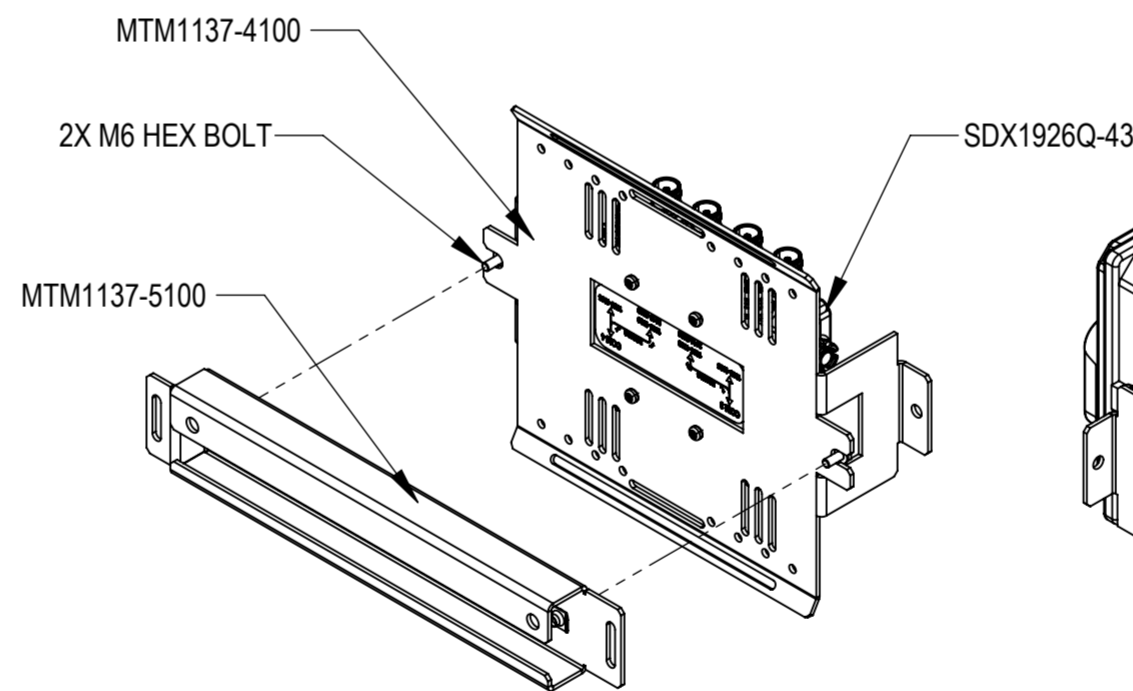

SDX1926Q-43 + RAYCAP
 1. INSTALL THE SDX1926Q-43 TO THE MOUNTING BRACKET 2 STES OF MTM1137-4100 AND 1 SET OF MTM1137-5100 USING 2 SETS OF M6 HARDWARE AS SHOWN
 2. INSTALL THE RAYCAP TO THE MOUNTING BRACKET 2 STES OF MTM1137-4100 AND 1 SET OF MTM1137-5100 USING 2 SETS OF M6 HARDWARE AS SHOWN

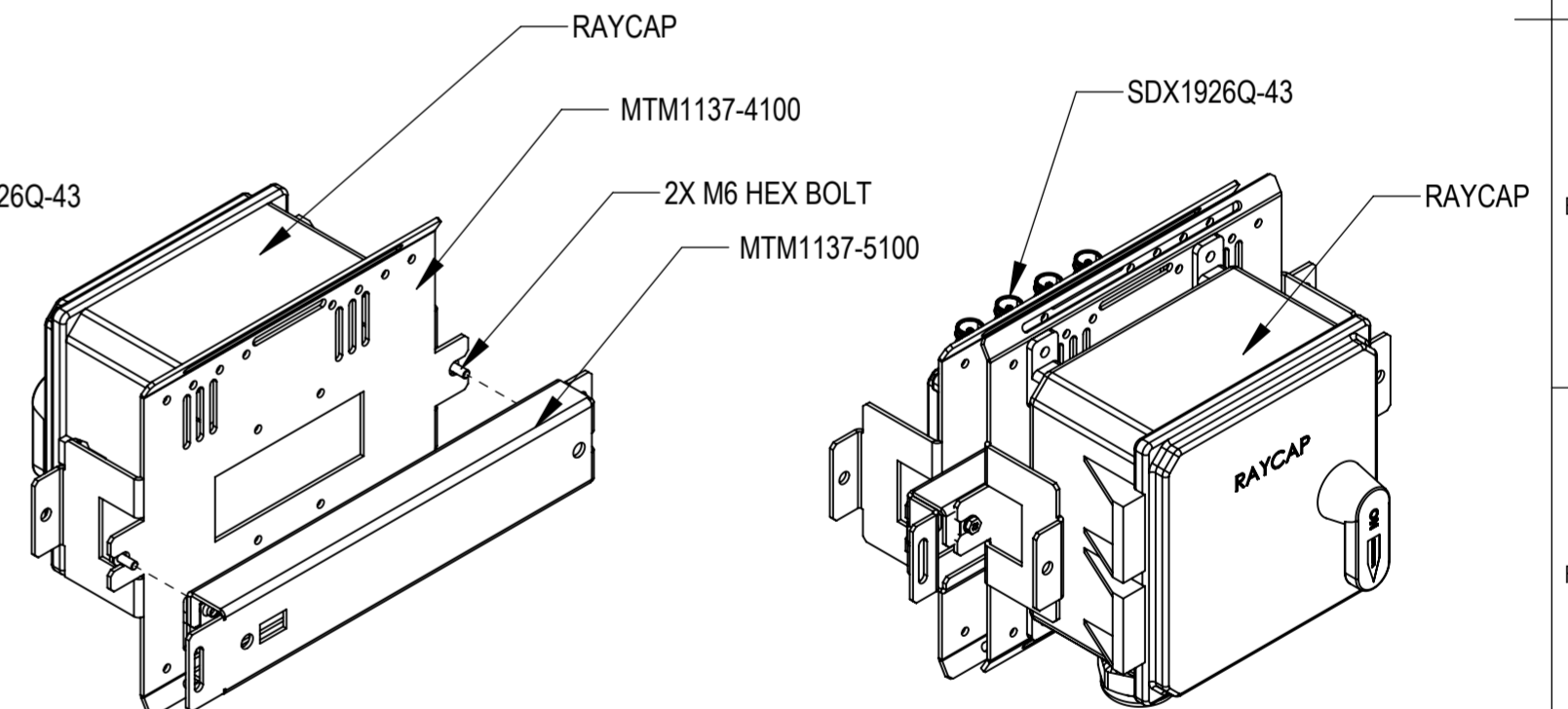

COMMSCOPE, INC. OF NORTH CAROLINA				
TITLE				
760251532N-INSTALL				
SIZE	SCALE	DOCUMENT NO.		
A2	1:10	760251532N-INSTALL		
DRAWING				SHEET
VERSION	STATUS	REVISION	3 OF 11	
01	RE	B		

HARDWARE INSTALLATION

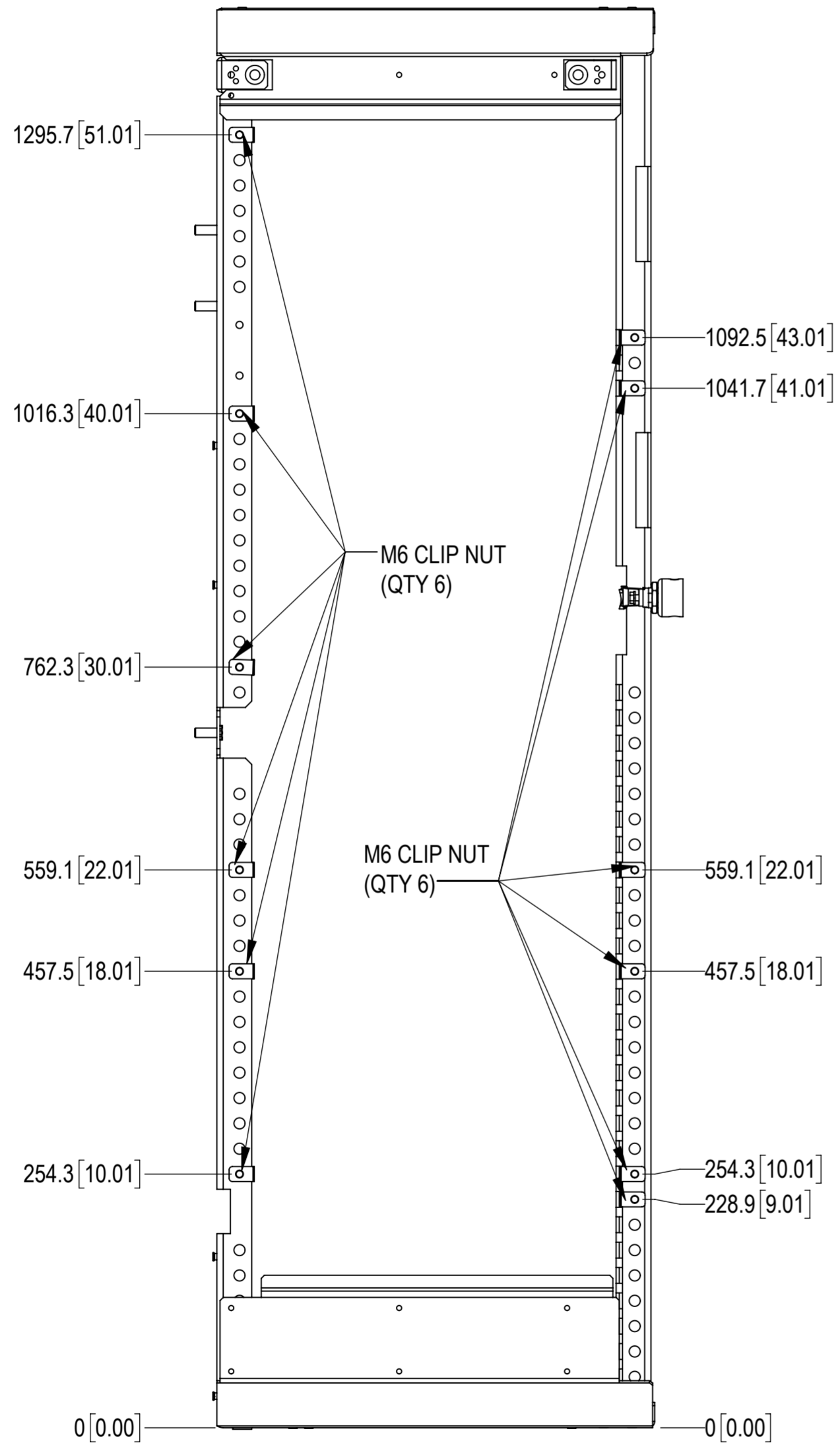

LEFT SIDE VIEW (DOORS REMOVED)

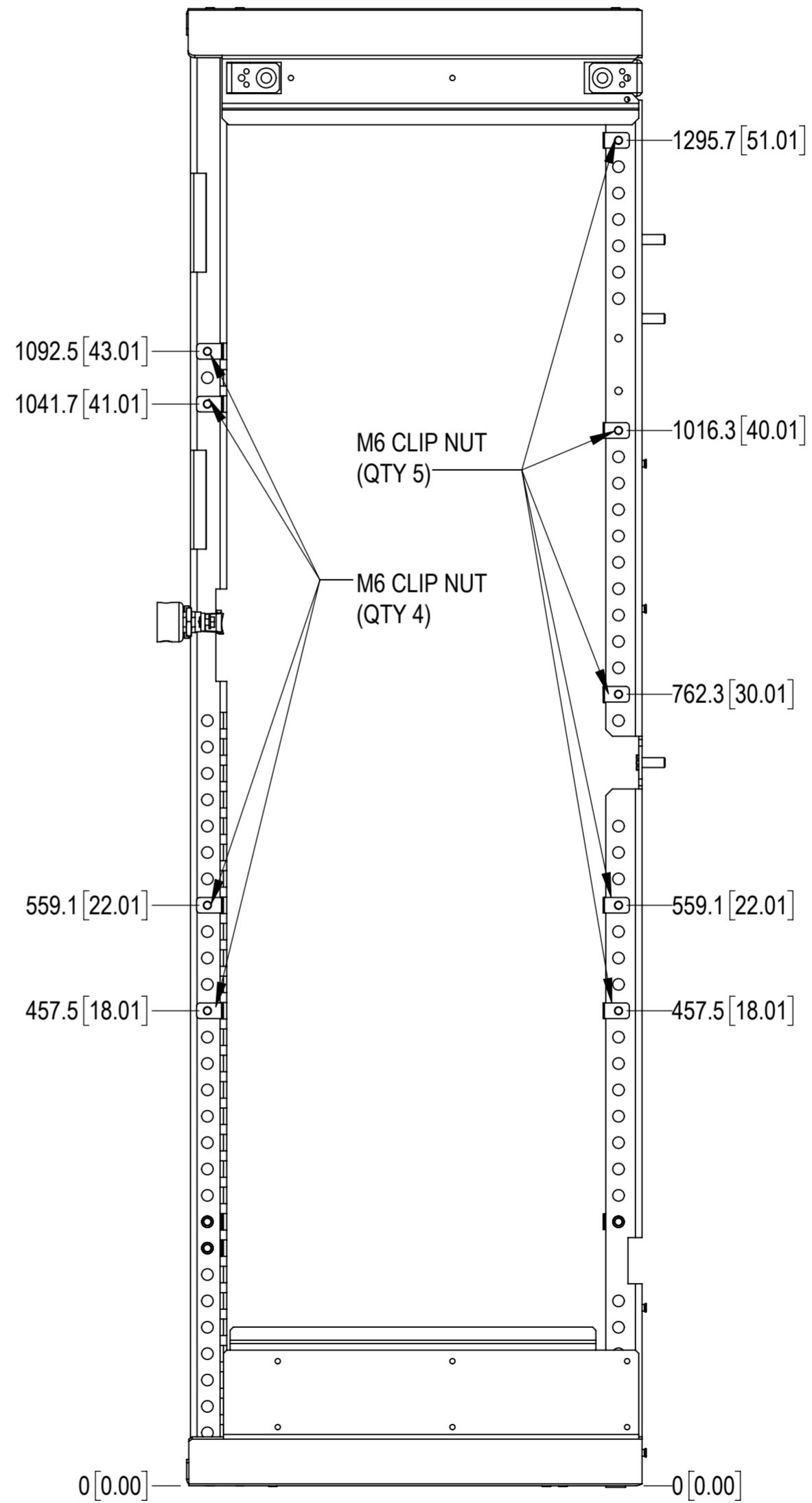

RIGHT SIDE VIEW (DOORS REMOVED)

COMMSCOPE, INC. OF NORTH CAROLINA				
TITLE				
760251532N-INSTALL				
SIZE	SCALE	DOCUMENT NO.		
A2	1:10	760251532N-INSTALL		
DRAWING				SHEET
VERSION	STATUS	REVISION	4 OF 11	
01	RE	B		

AHFIB + AHLBBA +2 X DELTA 2.0KW +SDX1926Q-43 + RAYCAP

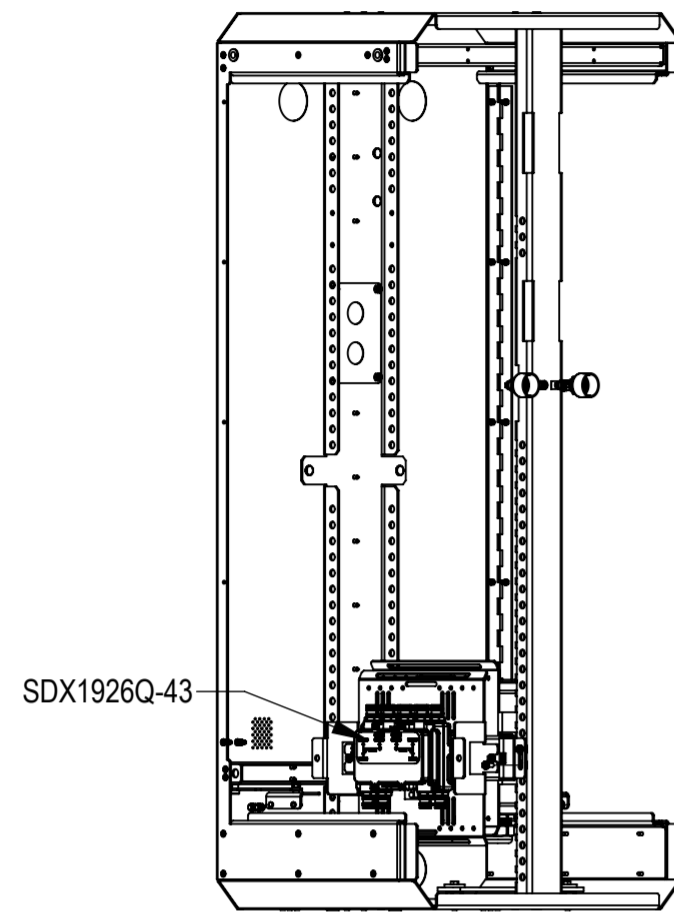

STEP 1:
SDX1926Q-43 + PAYCAP
HANG THIS ASSEMBLY TO THE EQUIPMENT MOUNT BRACKETS AND SECURE USING 3 SETS OF M6 HARDWARE, FLAT WASHER AND LOCK WASHER

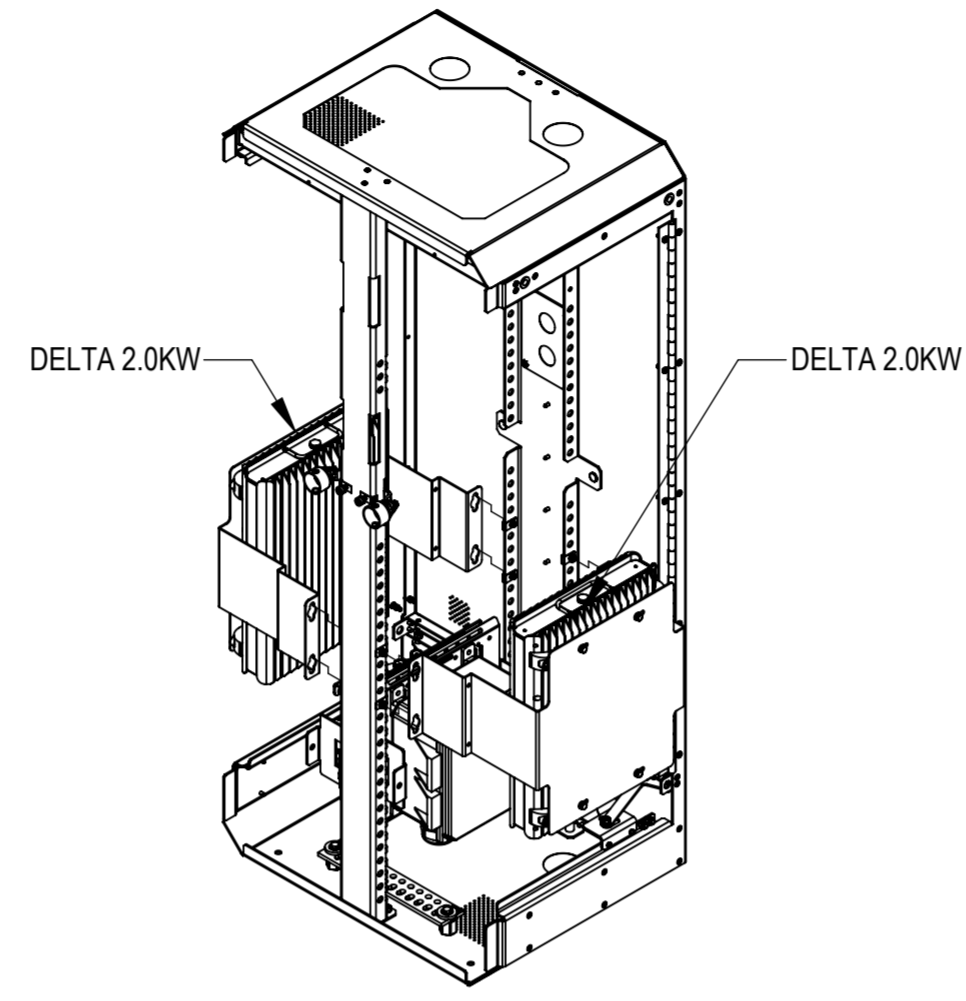

STEP 2:
DELTA 2.0KW
HANG THIS ASSEMBLY TO THE EQUIPMENT MOUNT BRACKETS AND SECURE USING 4 SETS OF M6 HARDWARE, FLAT WASHER AND LOCK WASHER

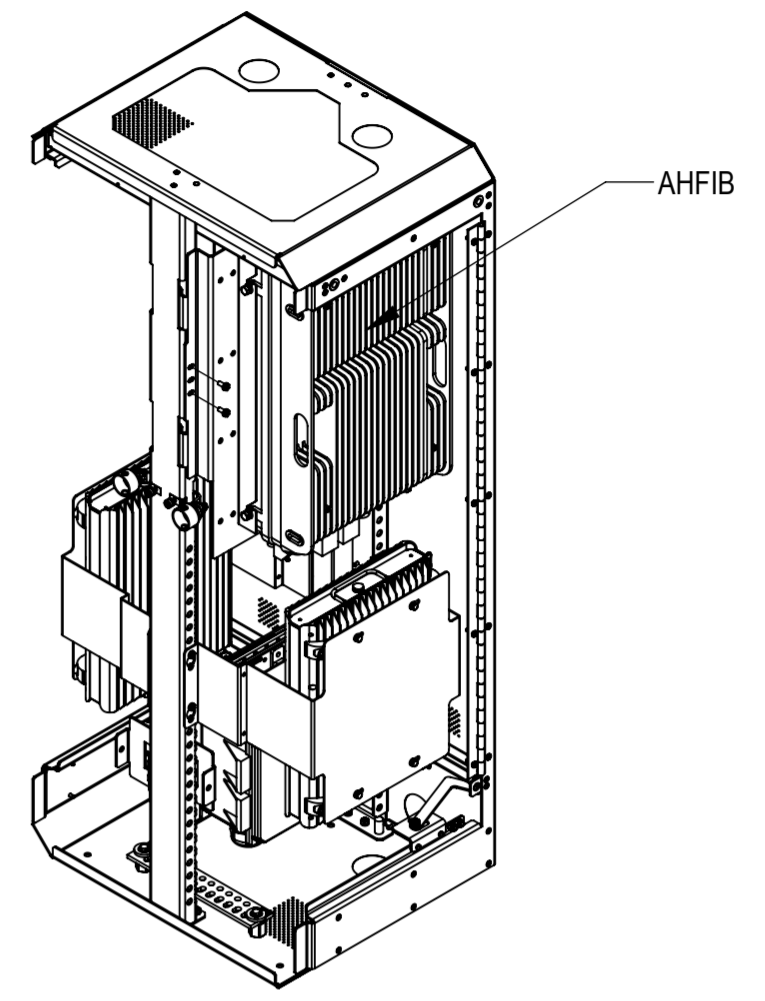

STEP 3:
AHFIB 320W
HANG THIS ASSEMBLY TO THE EQUIPMENT MOUNT BRACKETS AND SECURE USING 5 SETS OF M6 HARDWARE, FLAT WASHER AND LOCK WASHER

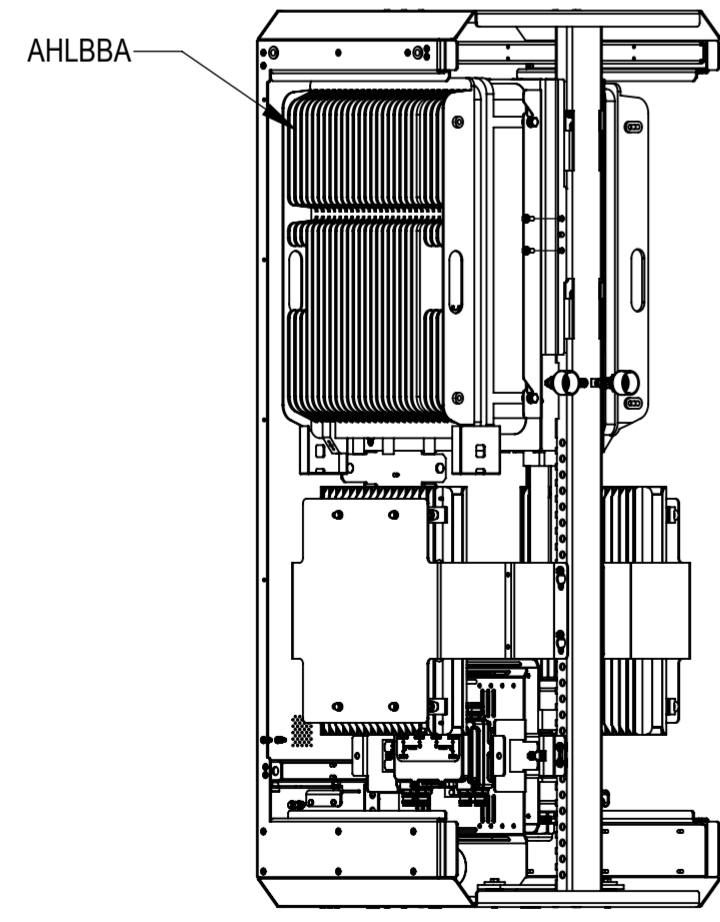

STEP 4:
AHLBBA
HANG THIS ASSEMBLY TO THE EQUIPMENT MOUNT BRACKETS AND SECURE USING 5 SETS OF M6 HARDWARE, FLAT WASHER AND LOCK WASHER

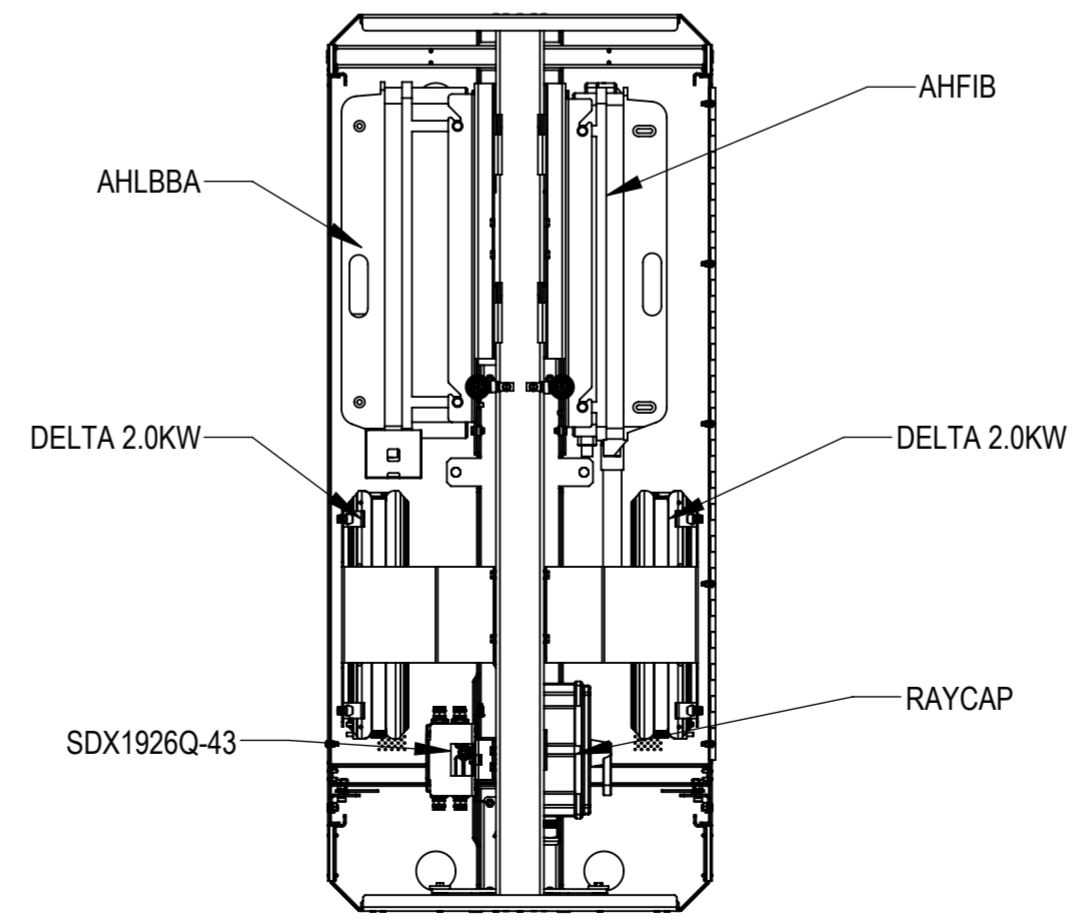

TOTAL INSTALLATION
THE FRONT DOOR IS HIDDEN FOR CLEAR VIEWING

COMMSCOPE, INC. OF NORTH CAROLINA				
TITLE 760251532N-INSTALL				
SIZE A2	SCALE 1:20	DOCUMENT NO. 760251532N-INSTALL		
DRAWING				SHEET
VERSION 01	STATUS RE	REVISION B	5 OF 11	

AHFIB + AHLBBA + 2 X CCI PSU-1200W-48-N +SDX1926Q-43 + RAYCAP

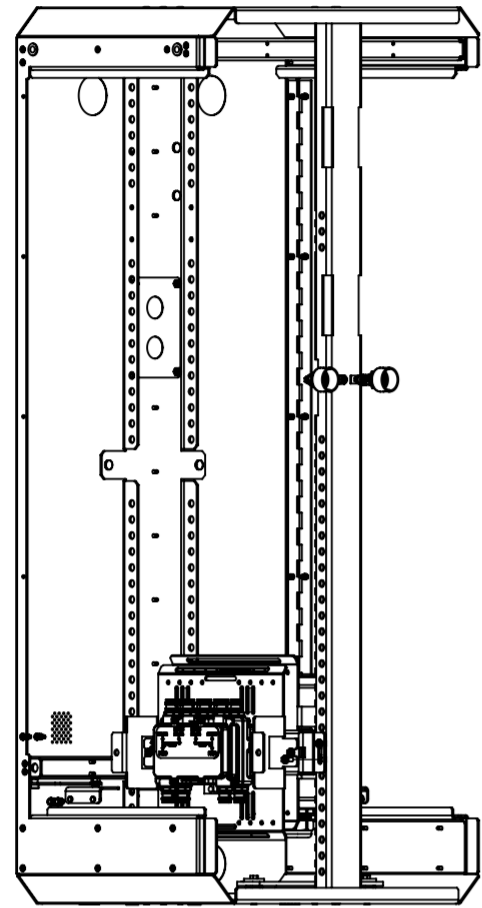

STEP 1:
SDX1926Q-43 + RAYCAP
HANG THIS ASSEMBLY TO THE EQUIPMENT MOUNT BRACKETS AND SECURE USING 3 SETS OF M6 HARDWARE, FLAT WASHER AND LOCK WASHER

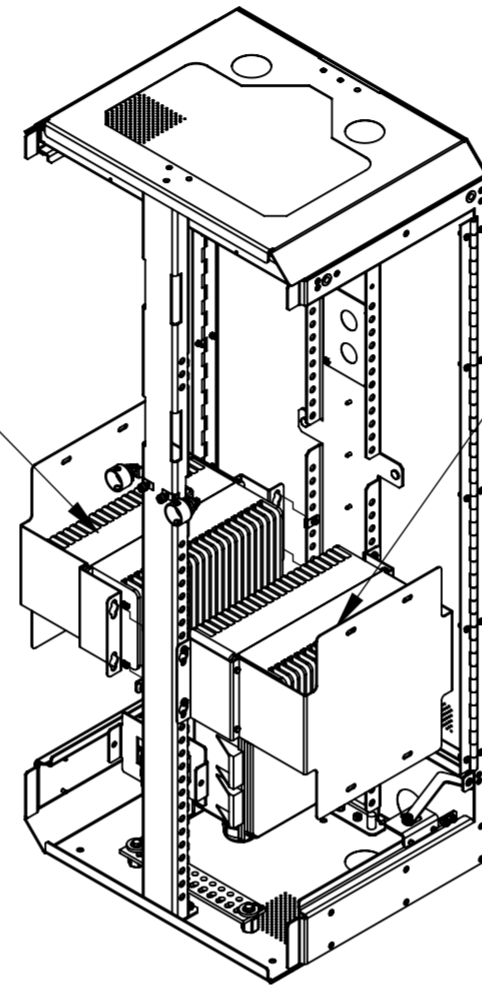

PSU-1200W-48-N PSU-1200W-48-N

STEP 2:
PSU-1200W-48-N
HANG THIS ASSEMBLY TO THE EQUIPMENT MOUNT BRACKETS AND SECURE USING 4 SETS OF M6 HARDWARE, FLAT WASHER AND LOCK WASHER

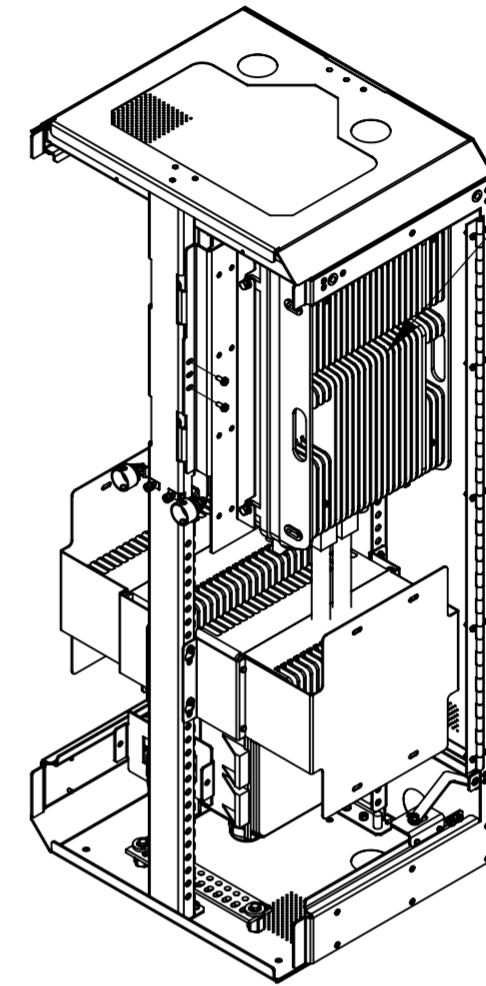

AHFIB

STEP 3:
AHFIB 320W
HANG THIS ASSEMBLY TO THE EQUIPMENT MOUNT BRACKETS AND SECURE USING 5 SETS OF M6 HARDWARE, FLAT WASHER AND LOCK WASHER

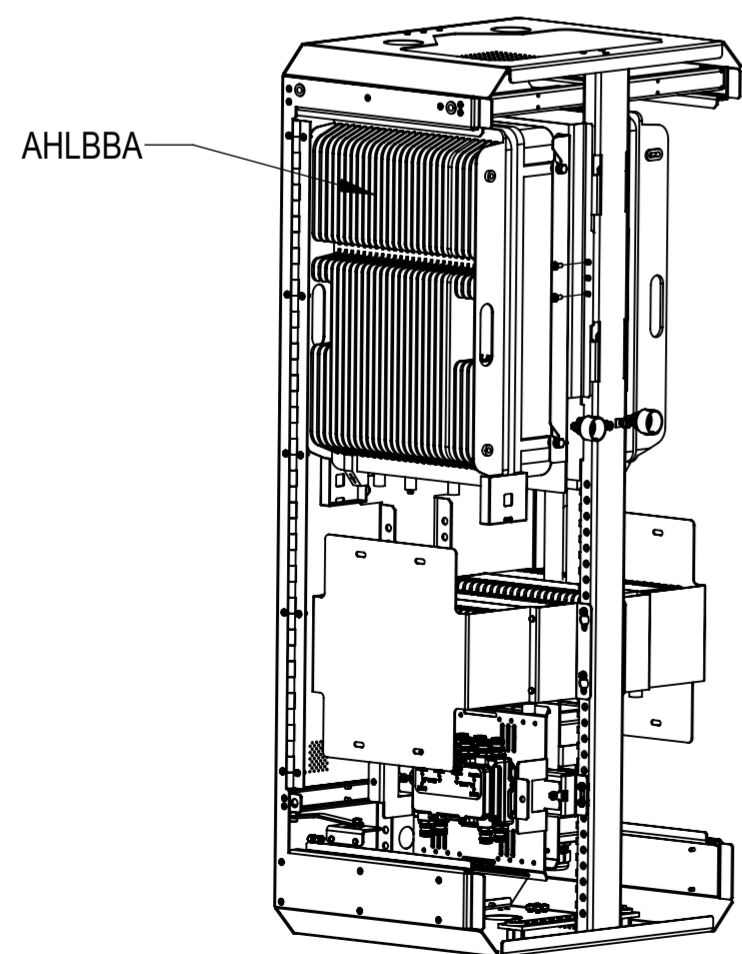

AHLBBA

STEP 4:
LEFT AFLBBA
HANG THIS ASSEMBLY TO THE EQUIPMENT MOUNT BRACKETS AND SECURE USING 5 SETS OF M6 HARDWARE, FLAT WASHER AND LOCK WASHER

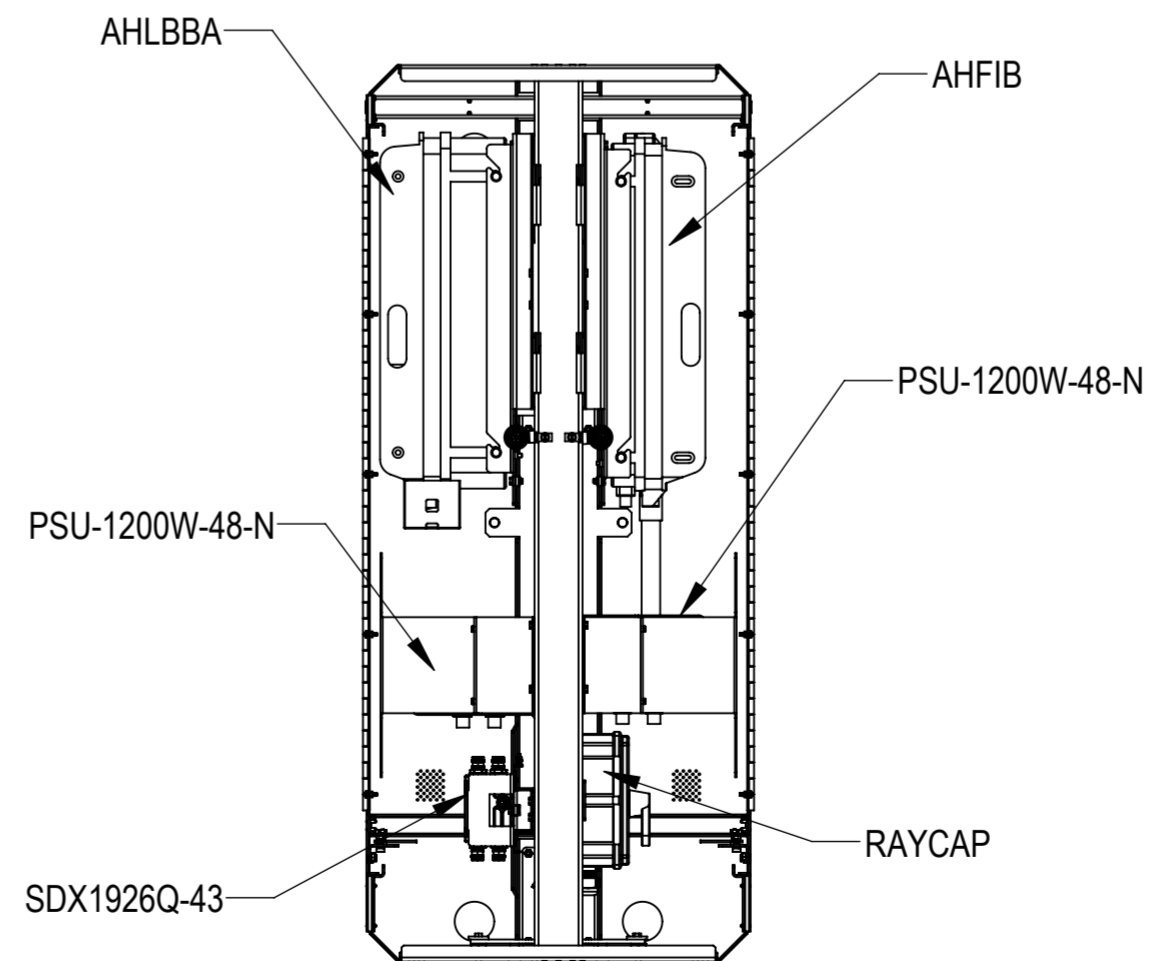

TOTAL INSTALLATION
THE FRONT DOOR IS HIDDEN FOR CLEAR VIEWING

COMMSCOPE, INC. OF NORTH CAROLINA				
TITLE 760251532N-INSTALL				
SIZE A2	SCALE 1:20	DOCUMENT NO. 760251532N-INSTALL		
		DRAWING		SHEET
		VERSION	STATUS	REVISION
		01	RE	B
				6 OF 11

2 X AHLBBA + 2 X DELTA 2.0KW + SDX1926Q-43 + RAYCAP

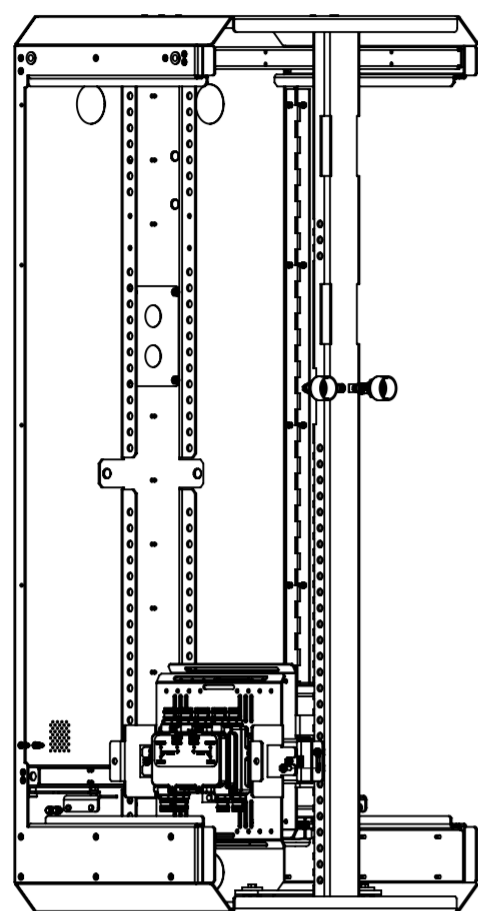

STEP 1:
SDX1926Q-43 + RAYCAP
HANG THIS ASSEMBLY TO THE EQUIPMENT MOUNT BRACKETS AND SECURE USING 3 SETS OF M6 HARDWARE, FLAT WASHER AND LOCK WASHER

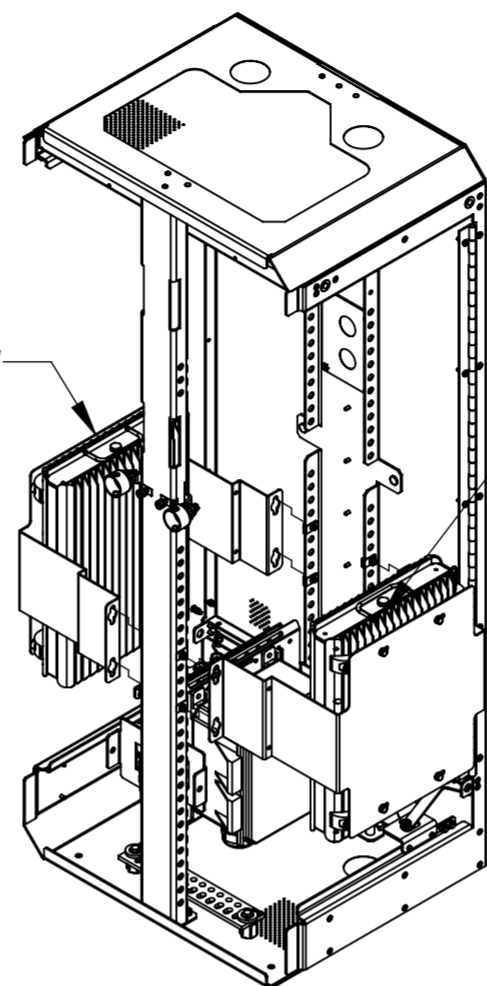

STEP 2:
DELTA 2.0KW
HANG THIS ASSEMBLY TO THE EQUIPMENT MOUNT BRACKETS AND SECURE USING 4 SETS OF M6 HARDWARE, FLAT WASHER AND LOCK WASHER

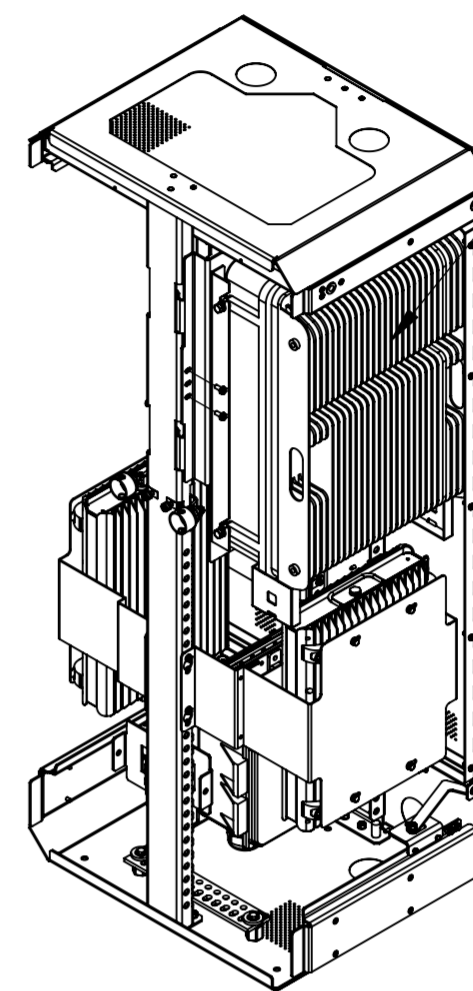

STEP 3:
RIGHT AHLBBA
HANG THIS ASSEMBLY TO THE EQUIPMENT MOUNT BRACKETS AND SECURE USING 5 SETS OF M6 HARDWARE, FLAT WASHER AND LOCK WASHER

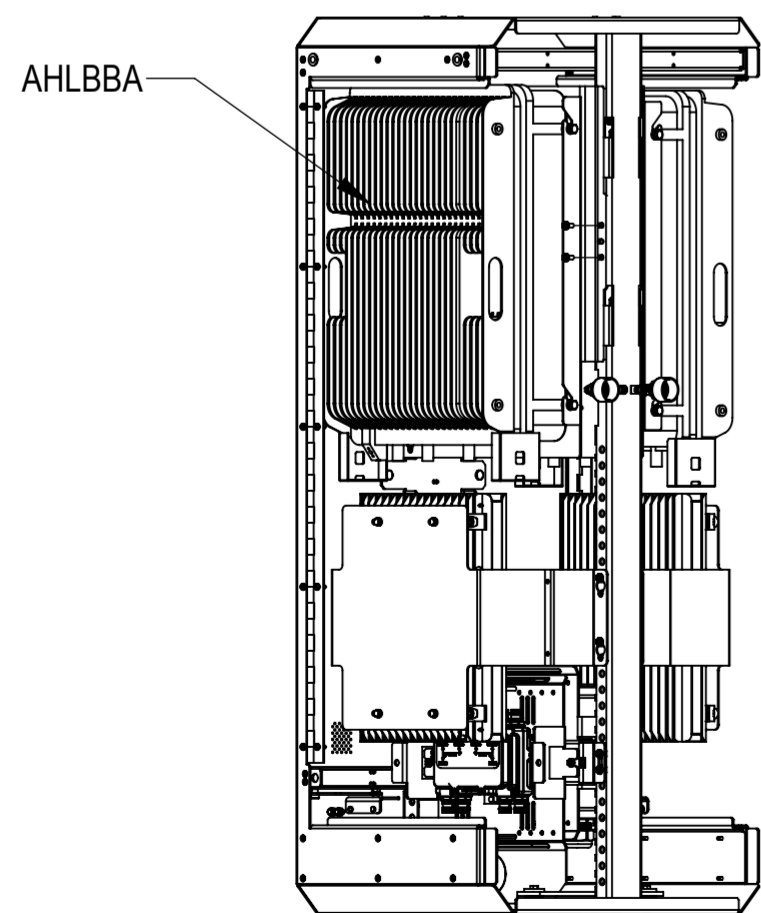

STEP 4:
LEFT AHLBBA
HANG THIS ASSEMBLY TO THE EQUIPMENT MOUNT BRACKETS AND SECURE USING 5 SETS OF M6 HARDWARE, FLAT WASHER AND LOCK WASHER

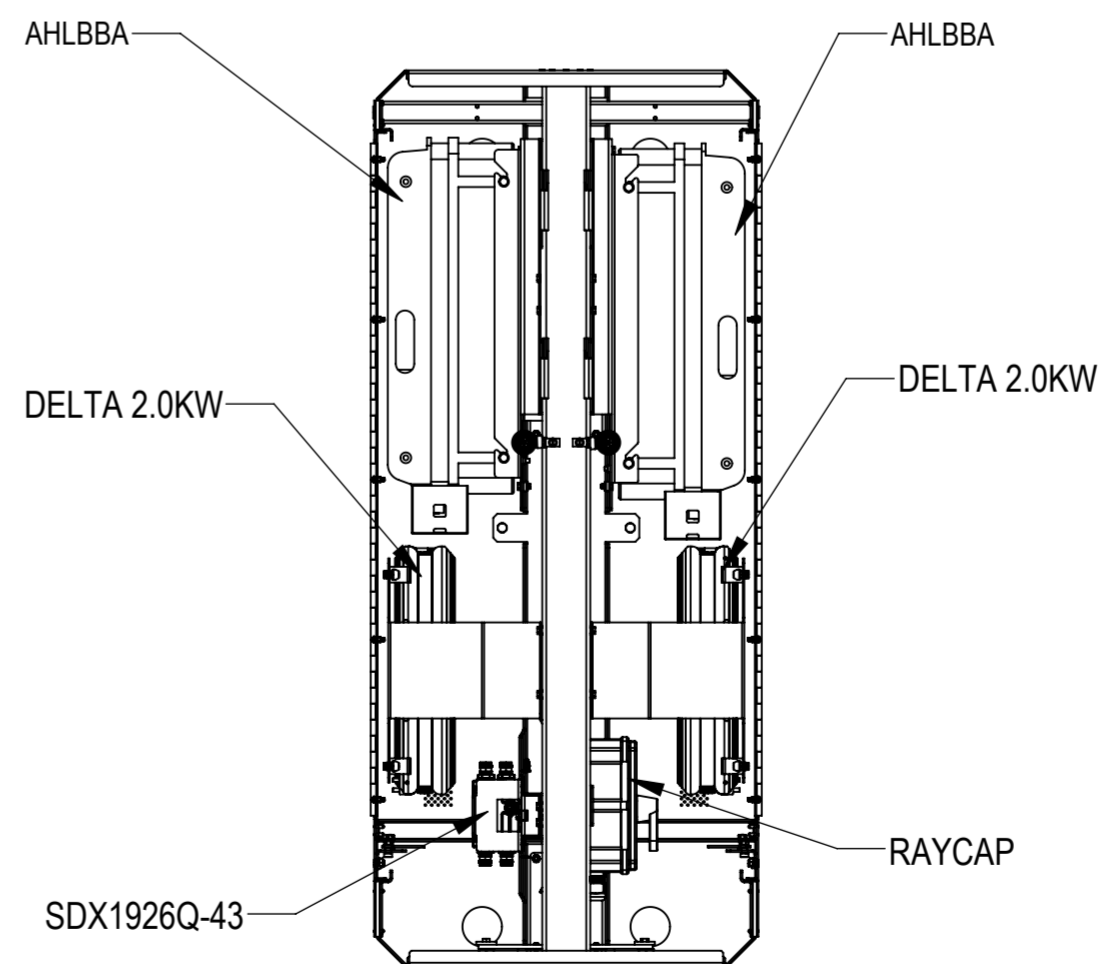

TOTAL INSTALLATION
THE FRONT DOOR IS HIDDEN FOR CLEAR VIEWING

COMMSCOPE, INC. OF NORTH CAROLINA				
TITLE				
760251532N-INSTALL				
SIZE	SCALE	DOCUMENT NO.		
A2	1:20	760251532N-INSTALL		
DRAWING				SHEET
VERSION	STATUS	REVISION	7 OF 11	
01	RE	B		

2 X AHLBBA + 2 X CCI PSU-1200W-48-N +SDX1926Q-43 + RAYCAP

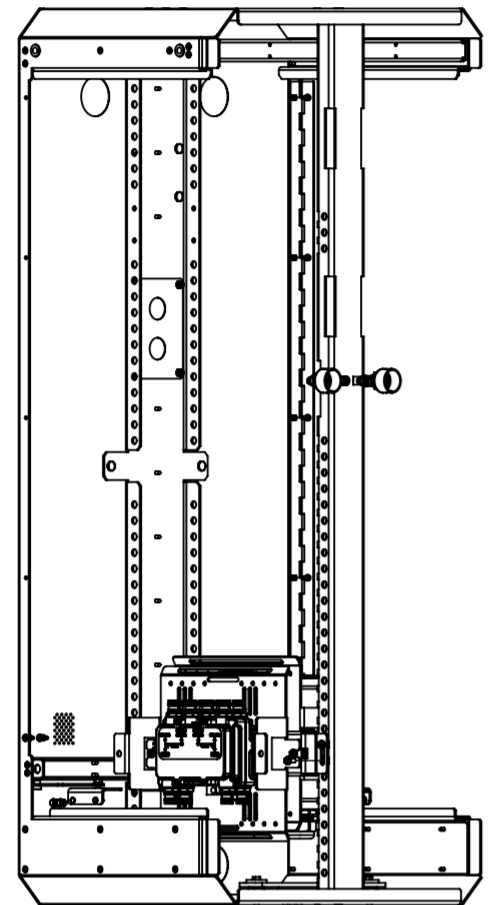

STEP 1:
SDX1926Q-43 + RAYCAP
HANG THIS ASSEMBLY TO THE EQUIPMENT MOUNT BRACKETS AND SECURE USING 3 SETS OF M6 HARDWARE, FLAT WASHER AND LOCK WASHER

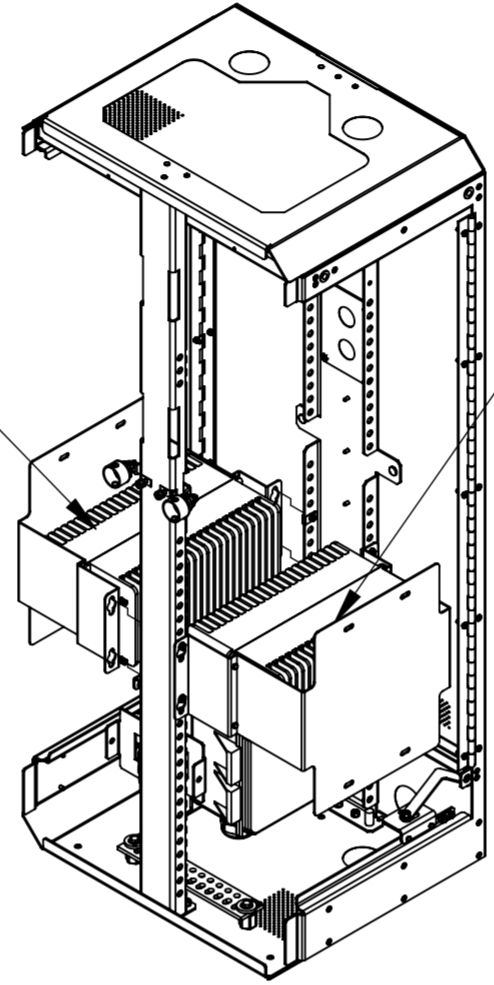

PSU-1200W-48-N PSU-1200W-48-N

STEP 2:
PSU-1200W-48-N
HANG THIS ASSEMBLY TO THE EQUIPMENT MOUNT BRACKETS AND SECURE USING 4 SETS OF M6 HARDWARE, FLAT WASHER AND LOCK WASHER

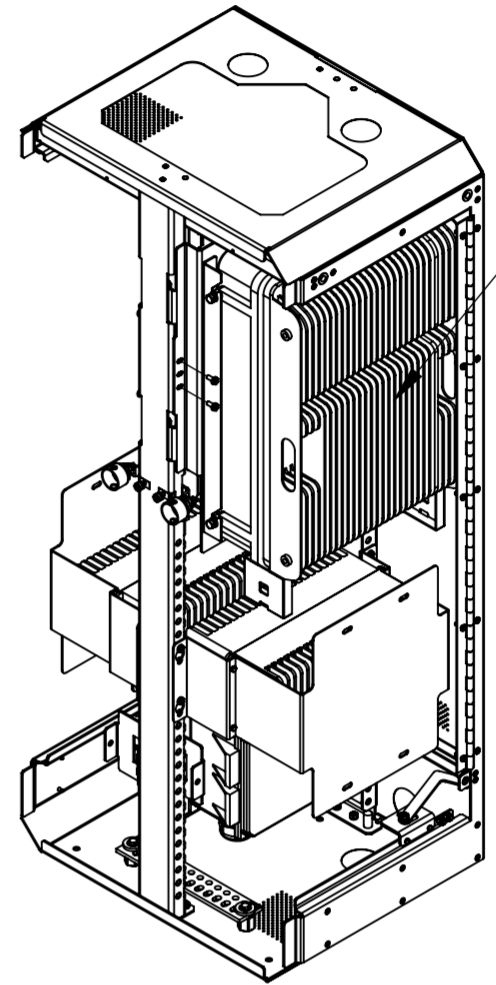

AHLBBA

STEP 3:
RIGHT AHLBBA
HANG THIS ASSEMBLY TO THE EQUIPMENT MOUNT BRACKETS AND SECURE USING 5 SETS OF M6 HARDWARE, FLAT WASHER AND LOCK WASHER

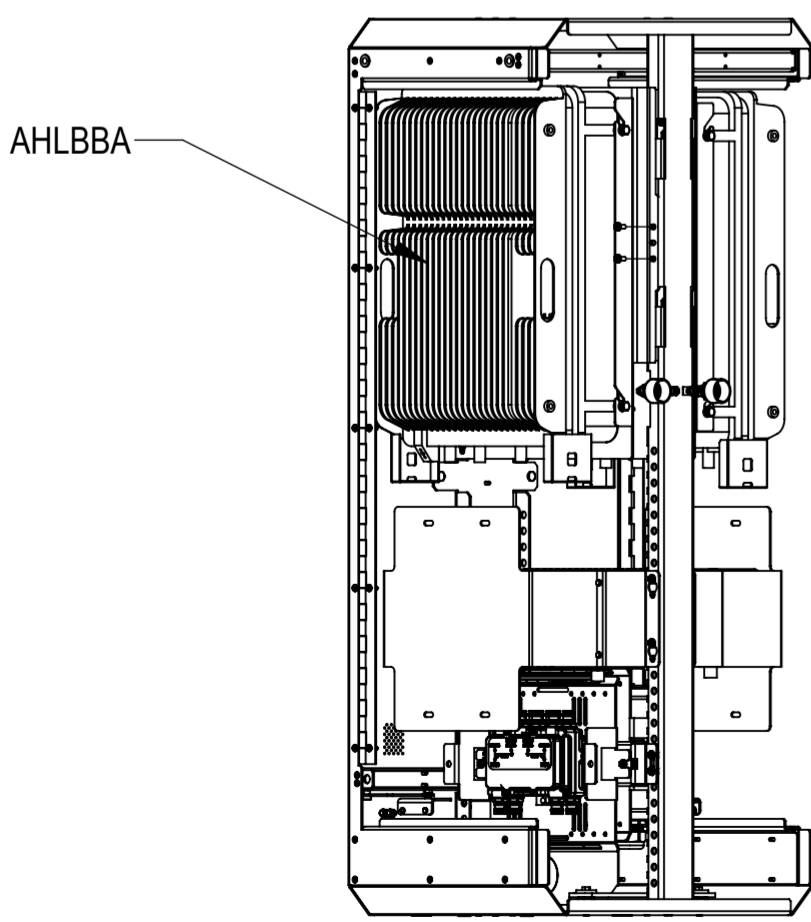

AHLBBA

STEP 4:
LEFT AHLBBA
HANG THIS ASSEMBLY TO THE EQUIPMENT MOUNT BRACKETS AND SECURE USING 5 SETS OF M6 HARDWARE, FLAT WASHER AND LOCK WASHER

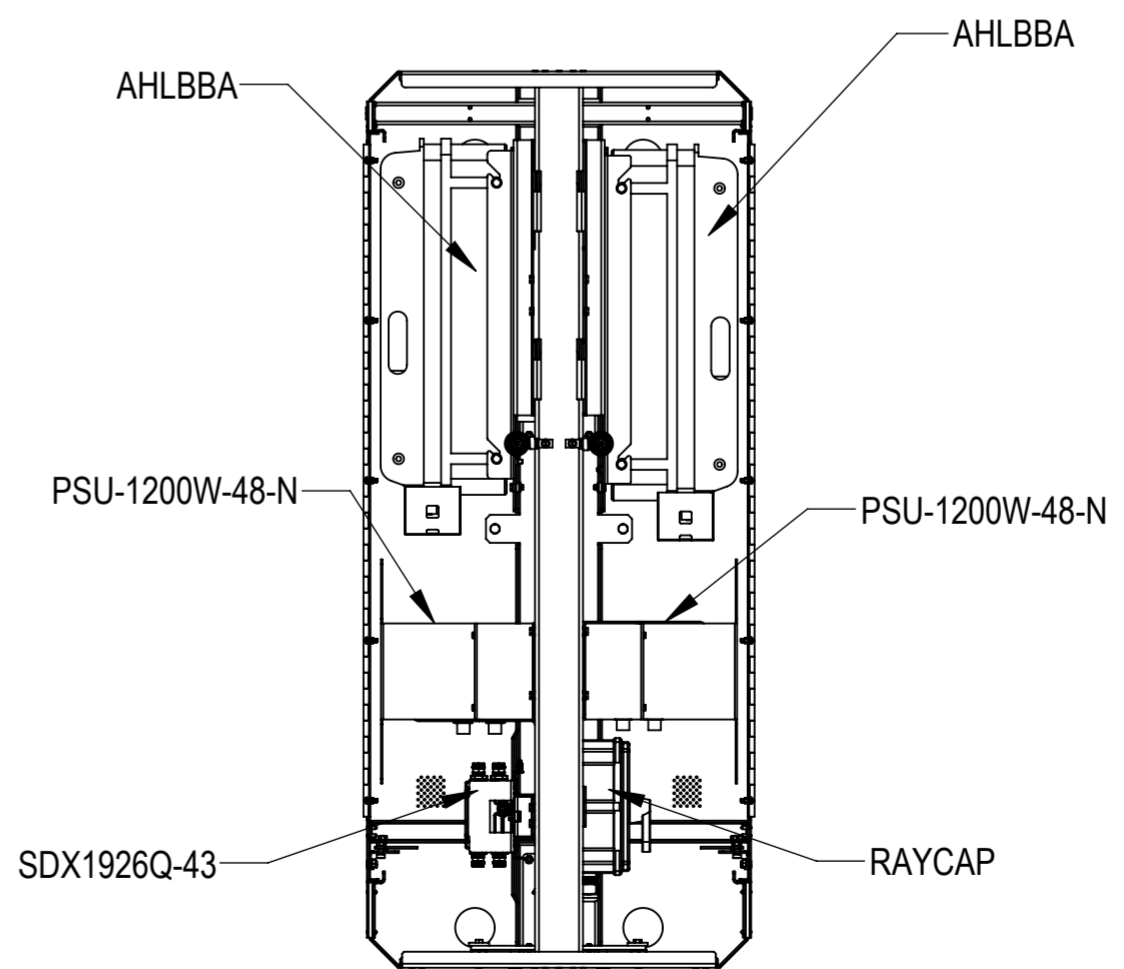

TOTAL INSTALLATION
THE FRONT DOOR IS HIDDEN FOR CLEAR VIEWING

COMMSCOPE, INC. OF NORTH CAROLINA				
TITLE 760251532N-INSTALL				
SIZE A2	SCALE 1:20	DOCUMENT NO. 760251532N-INSTALL		
		DRAWING		SHEET
		VERSION	STATUS	REVISION
		01	RE	B
				8 OF 11

AHFIB + AHLBA + 2 X DELTA 2.0KW +SDX1926Q-43 + RAYCAP

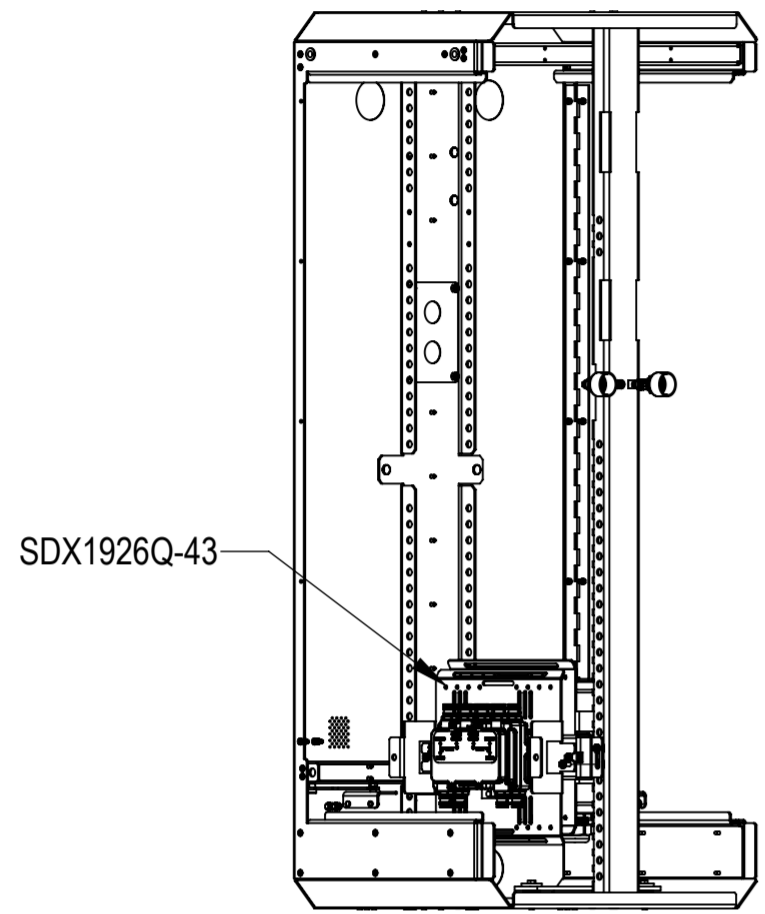

SDX1926Q-43

STEP 1:
SDX1926Q-43 + PAYCAP
HANG THIS ASSEMBLY TO THE EQUIPMENT MOUNT BRACKETS AND SECURE USING 3 SETS OF M6 HARDWARE, FLAT WASHER AND LOCK WASHER

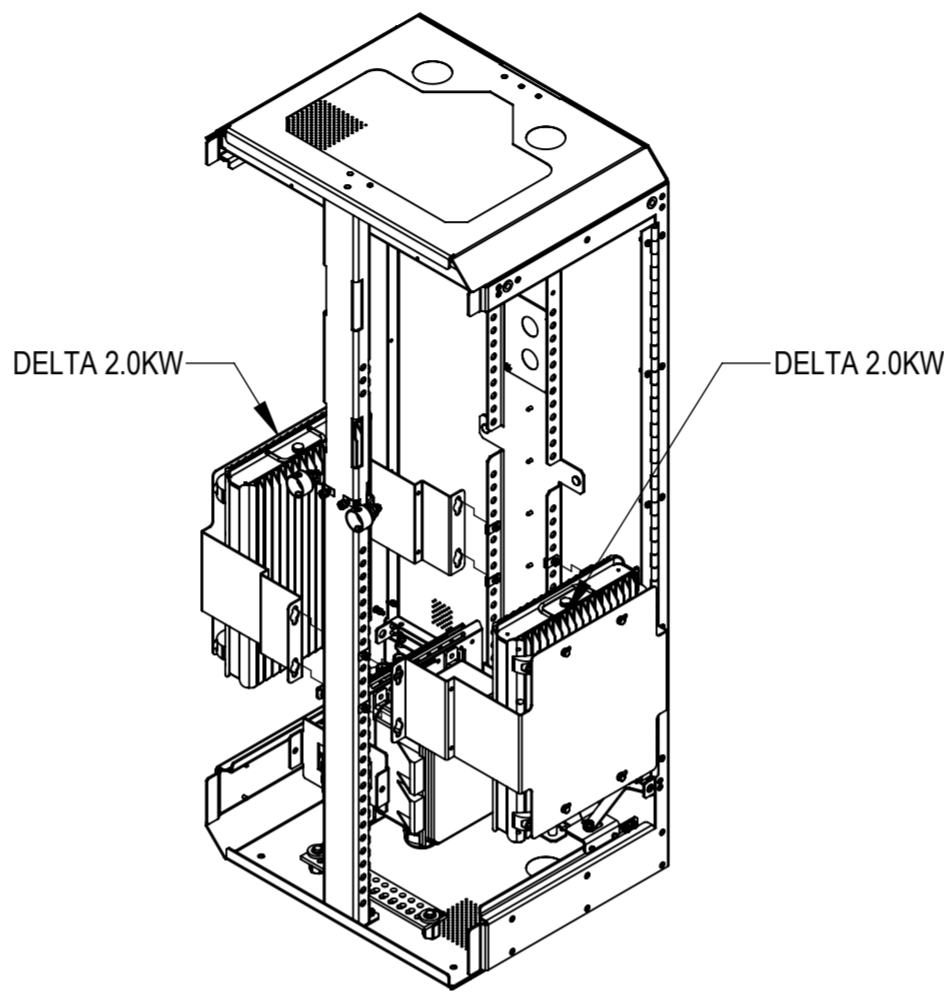

DELTA 2.0KW

DELTA 2.0KW

STEP 2:
DELTA 2.0KW
HANG THIS ASSEMBLY TO THE EQUIPMENT MOUNT BRACKETS AND SECURE USING 4 SETS OF M6 HARDWARE, FLAT WASHER AND LOCK WASHER

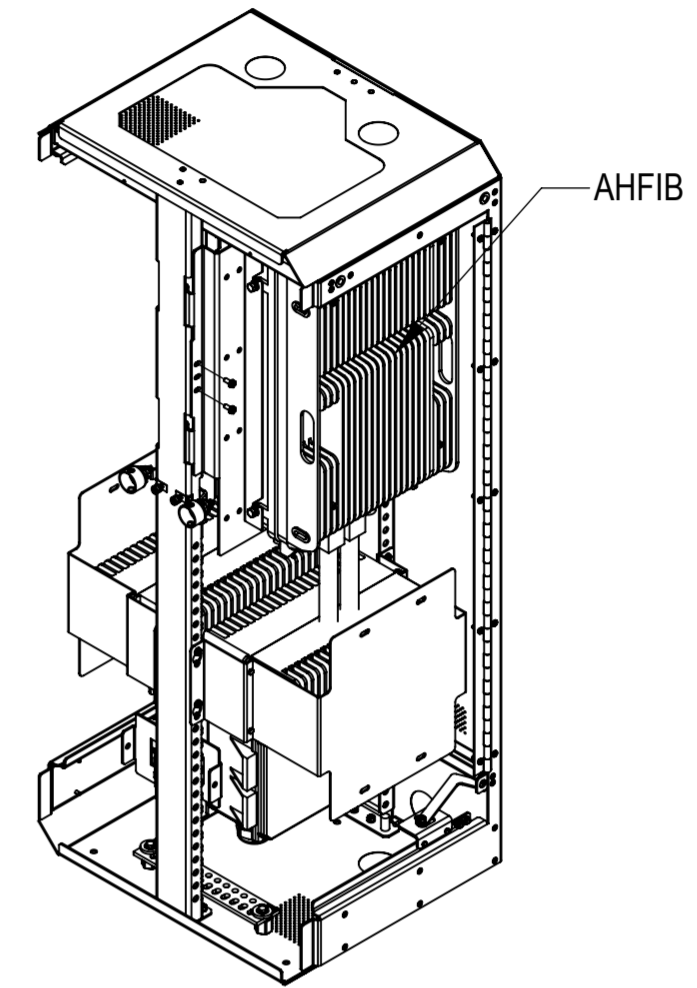

AHFIB

STEP 3:
AHFIB 320W
HANG THIS ASSEMBLY TO THE EQUIPMENT MOUNT BRACKETS AND SECURE USING 5 SETS OF M6 HARDWARE, FLAT WASHER AND LOCK WASHER

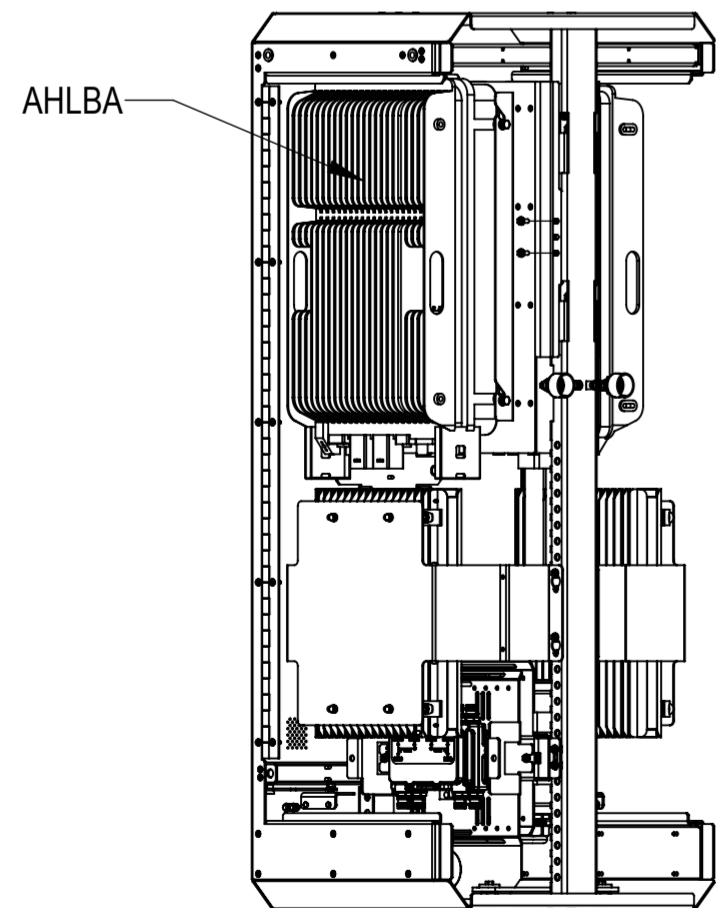

AHLBA

STEP 4:
LEFT AHLBA
HANG THIS ASSEMBLY TO THE EQUIPMENT MOUNT BRACKETS AND SECURE USING 5 SETS OF M6 HARDWARE, FLAT WASHER AND LOCK WASHER

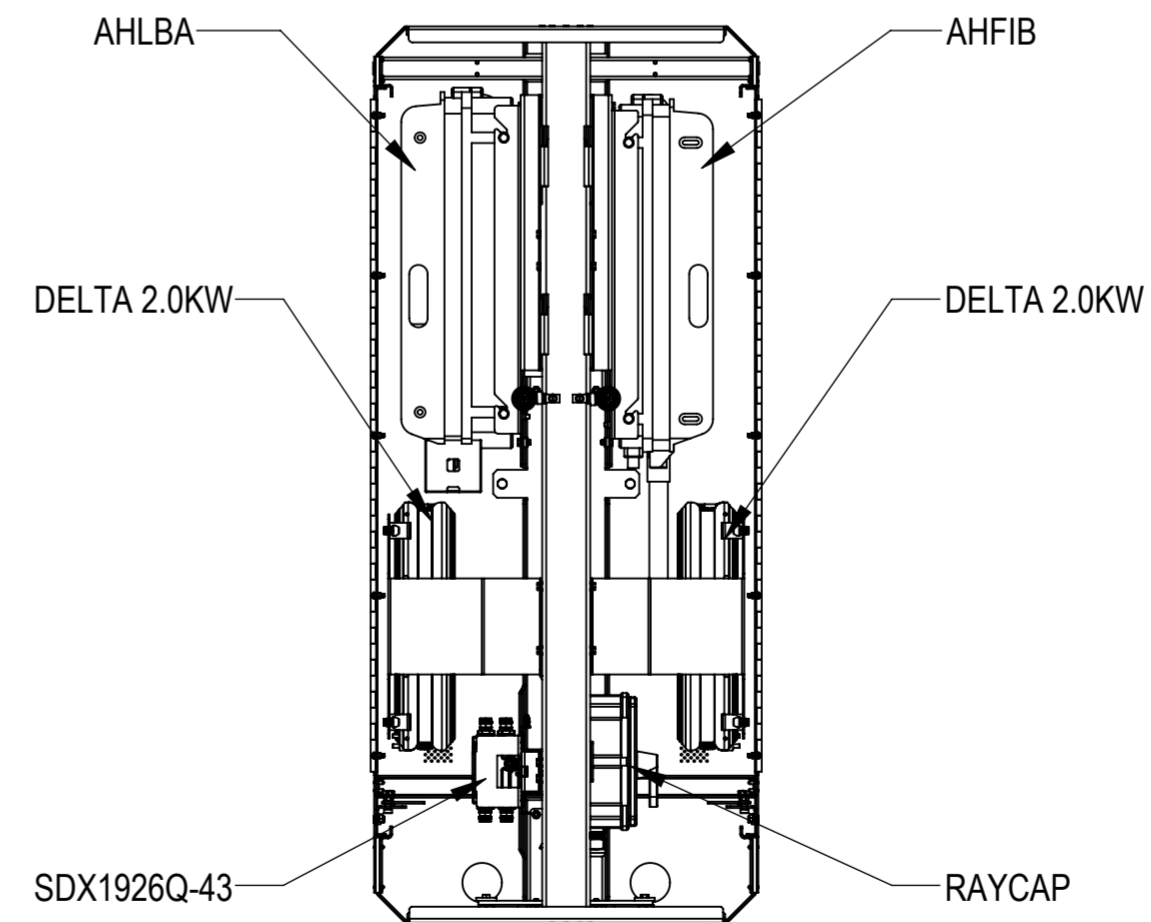

AHLBA

AHFIB

DELTA 2.0KW

DELTA 2.0KW

SDX1926Q-43

RAYCAP

TOTAL INSTALLATION
THE FRONT DOOR IS HIDDEN FOR CLEAR VIEWING

COMMSCOPE, INC. OF NORTH CAROLINA				
TITLE				
760251532N-INSTALL				
SIZE	SCALE	DOCUMENT NO.		
A2	1:20	760251532N-INSTALL		
DRAWING				SHEET
VERSION	STATUS	REVISION	9 OF 11	
01	RE	B		

AHFIB + AHLBA +2 X CCI PSU-1200W-48-N + SDX1926Q-43 + RAYCAP

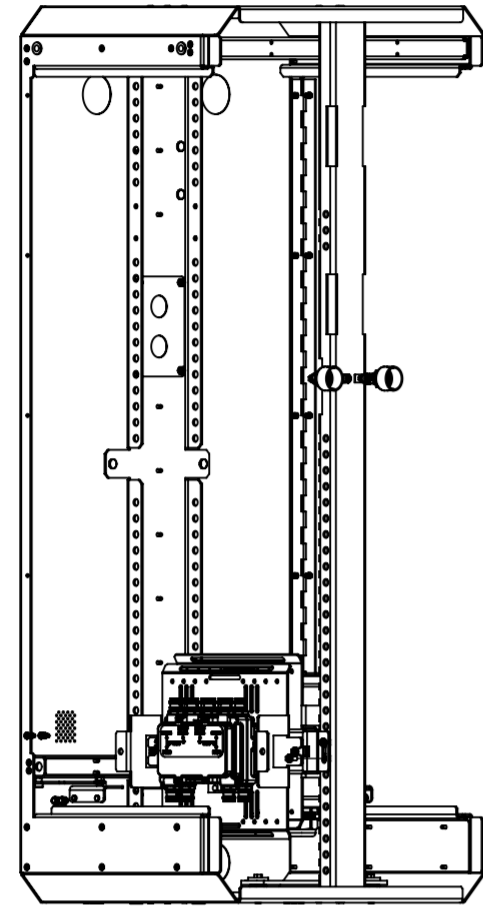

STEP 1:
SDX1926Q-43 + RAYCAP
HANG THIS ASSEMBLY TO THE EQUIPMENT MOUNT BRACKETS AND SECURE USING 3 SETS OF M6 HARDWARE, FLAT WASHER AND LOCK WASHER

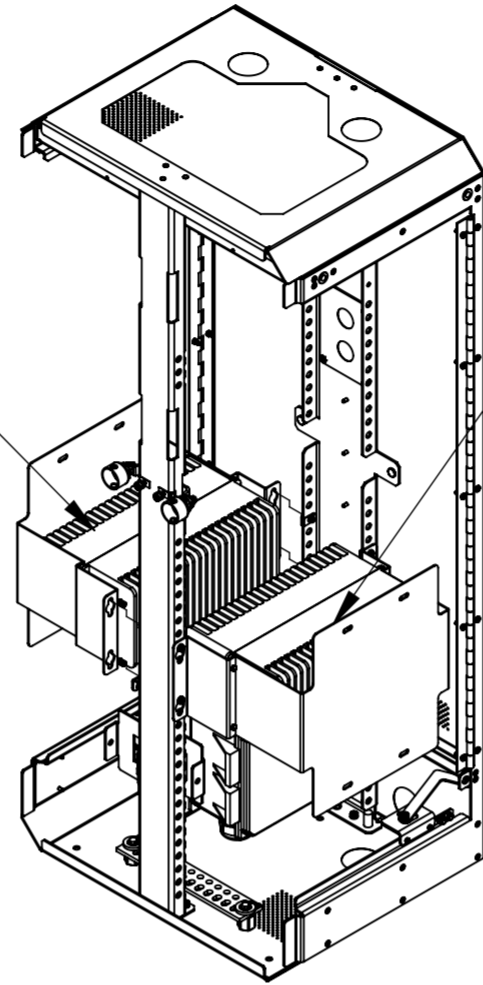

PSU-1200W-48-N PSU-1200W-48-N

STEP 2:
PSU-1200W-48-N
HANG THIS ASSEMBLY TO THE EQUIPMENT MOUNT BRACKETS AND SECURE USING 4 SETS OF M6 HARDWARE, FLAT WASHER AND LOCK WASHER

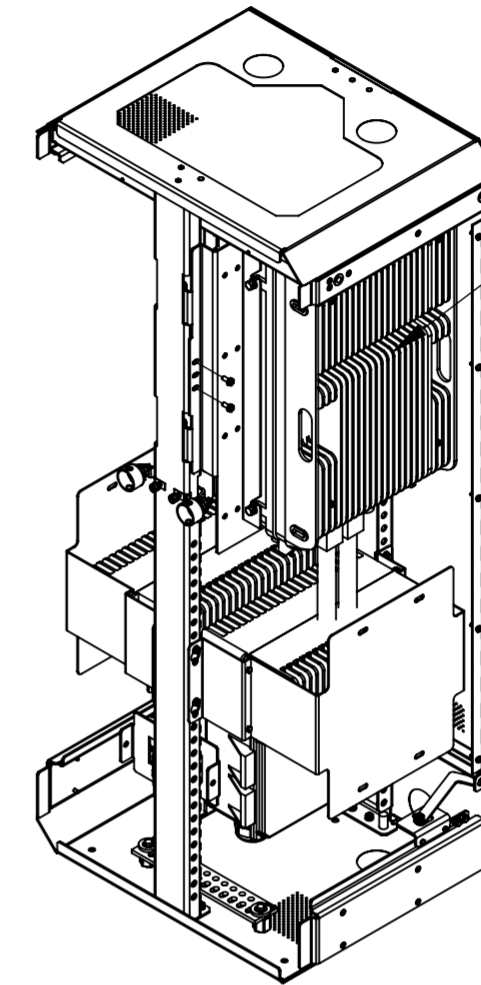

AHFIB

STEP 3:
AHFIB 320W
HANG THIS ASSEMBLY TO THE EQUIPMENT MOUNT BRACKETS AND SECURE USING 5 SETS OF M6 HARDWARE, FLAT WASHER AND LOCK WASHER

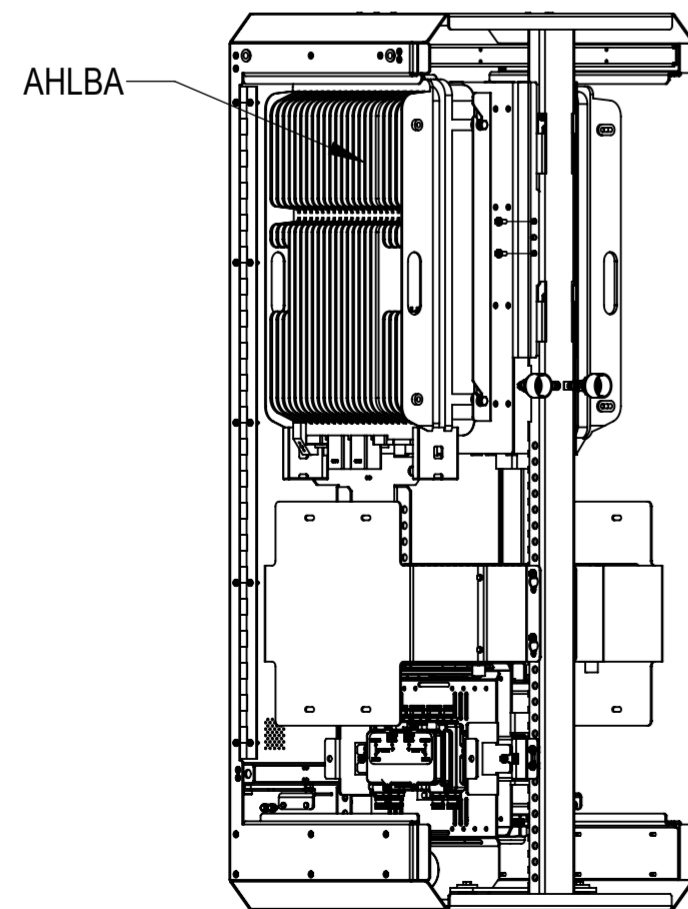

AHLBA

STEP 4:
LEFT AHLBA
HANG THIS ASSEMBLY TO THE EQUIPMENT MOUNT BRACKETS AND SECURE USING 5 SETS OF M6 HARDWARE, FLAT WASHER AND LOCK WASHER

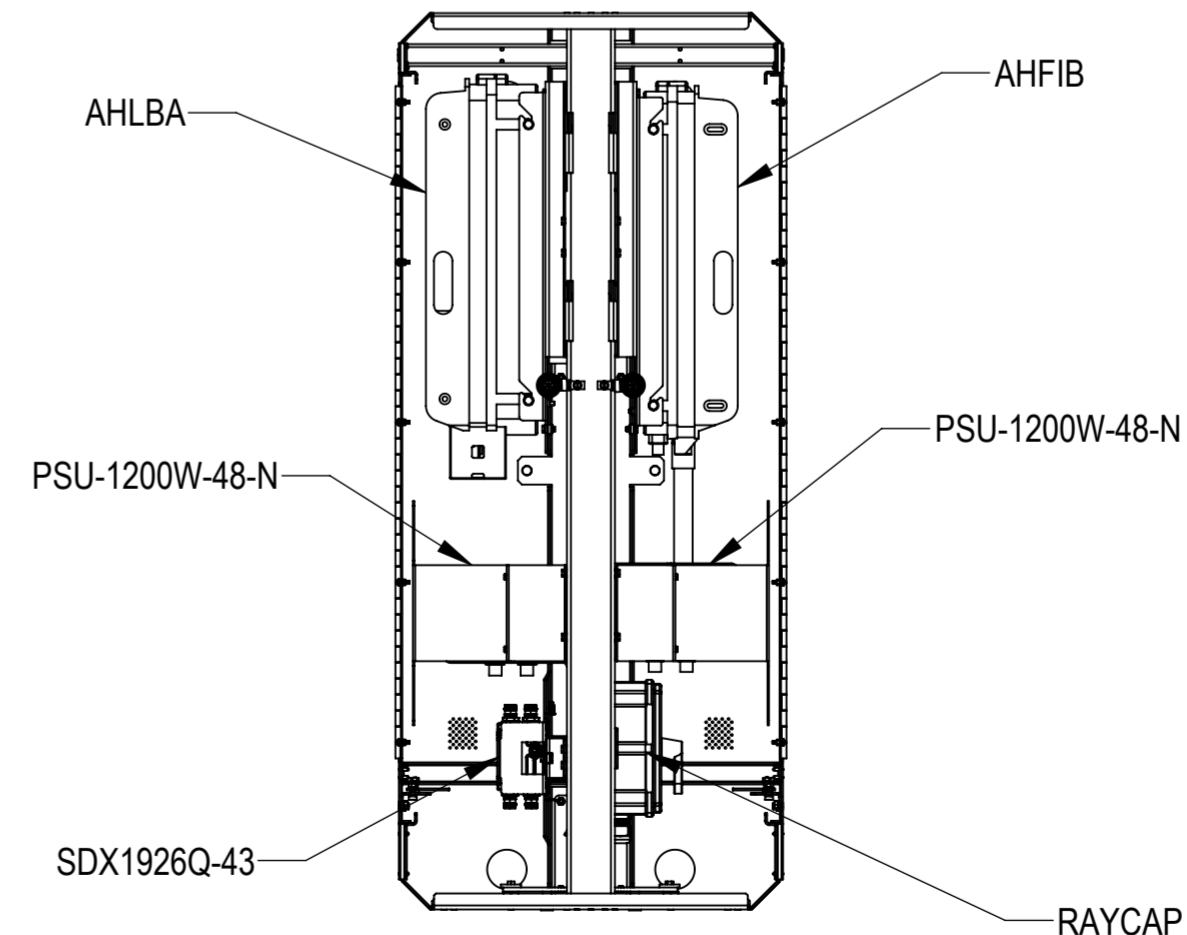

AHLBA

AHFIB

PSU-1200W-48-N

PSU-1200W-48-N

SDX1926Q-43

RAYCAP

TOTAL INSTALLATION
THE FRONT DOOR IS HIDDEN FOR CLEAR VIEWING

COMMSCOPE, INC. OF NORTH CAROLINA				
TITLE 760251532N-INSTALL				
SIZE A2	SCALE 1:20	DOCUMENT NO. 760251532N-INSTALL		
DRAWING				SHEET
VERSION 01	STATUS RE	REVISION B	10 OF 11	

AHFIB + AHLBBA +2 X DELTA 2.0KW +SDX1926Q-43 + RAYCAP + AZRB

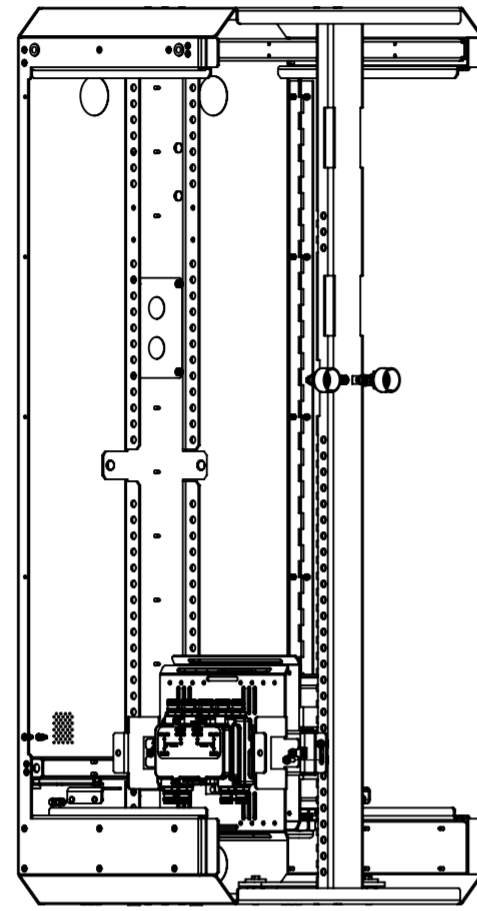

STEP 1:
SDX1926Q-43 + PAYCAP
HANG THIS ASSEMBLY TO THE EQUIPMENT MOUNT BRACKETS AND SECURE USING 3 SETS OF M6 HARDWARE, FLAT WASHER AND LOCK WASHER

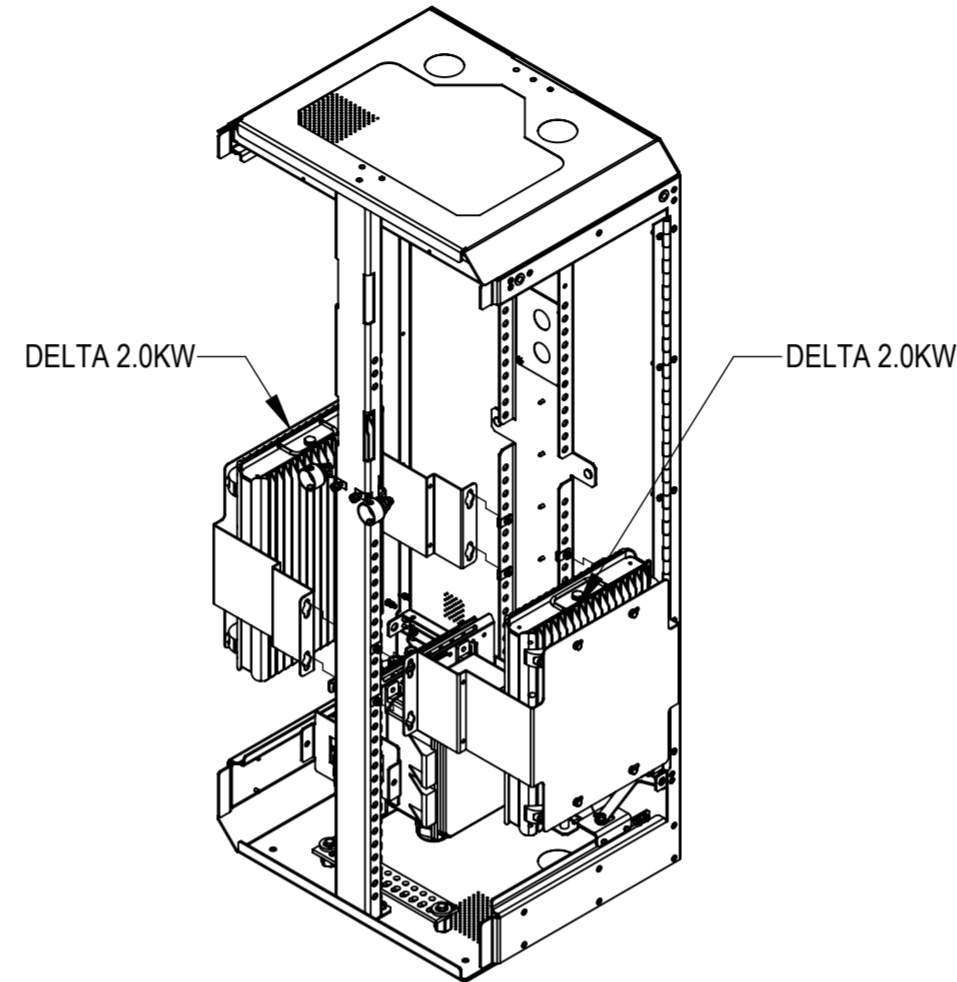

STEP 2:
DELTA 2.0KW
HANG THIS ASSEMBLY TO THE EQUIPMENT MOUNT BRACKETS AND SECURE USING 4 SETS OF M6 HARDWARE, FLAT WASHER AND LOCK WASHER

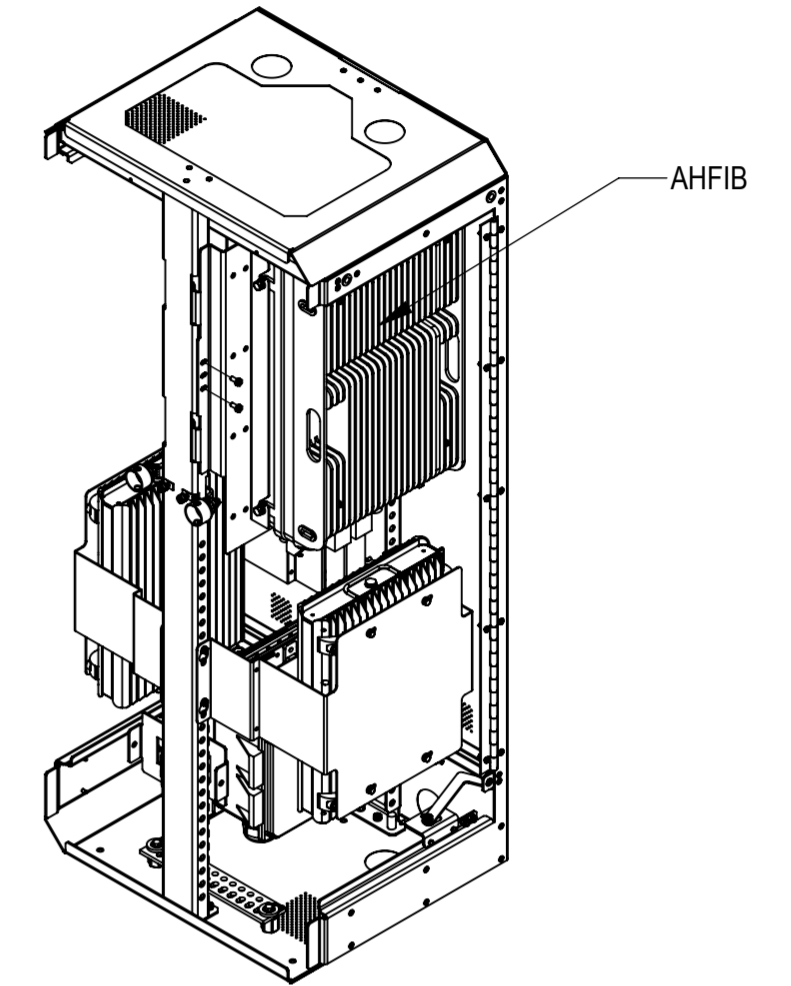

STEP 3:
AHFIB 320W
HANG THIS ASSEMBLY TO THE EQUIPMENT MOUNT BRACKETS AND SECURE USING 5 SETS OF M6 HARDWARE, FLAT WASHER AND LOCK WASHER

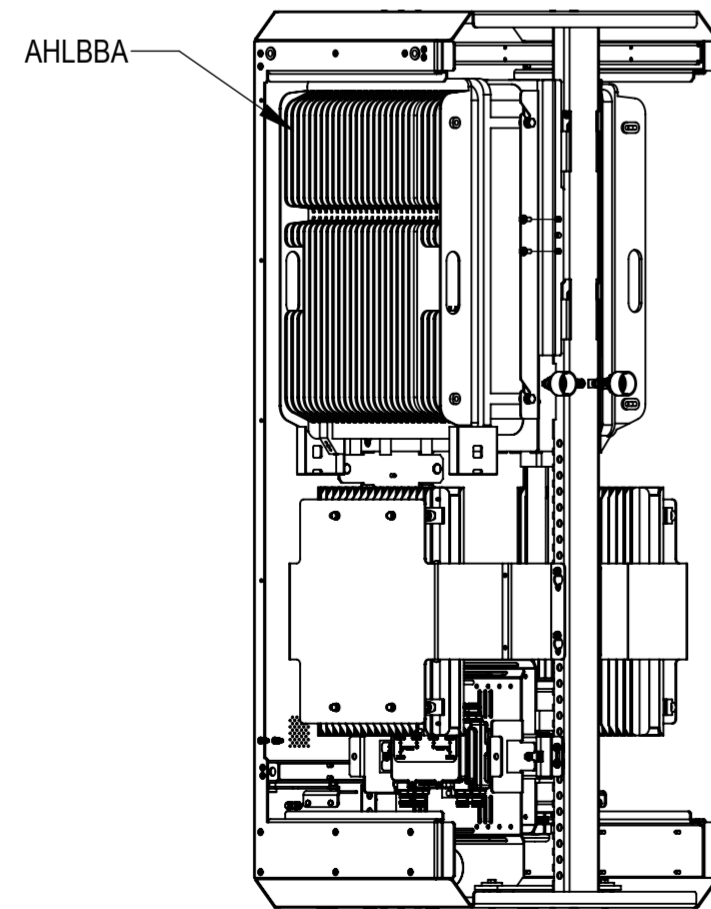

STEP 4:
AHLBBA + AZRB
INSTALL AHLBBA + AZRB TO BRACKET MTM1161-1100
HANG THIS ASSEMBLY TO THE EQUIPMENT MOUNT BRACKETS AND SECURE USING 5 SETS OF M6 HARDWARE, FLAT WASHER AND LOCK WASHER

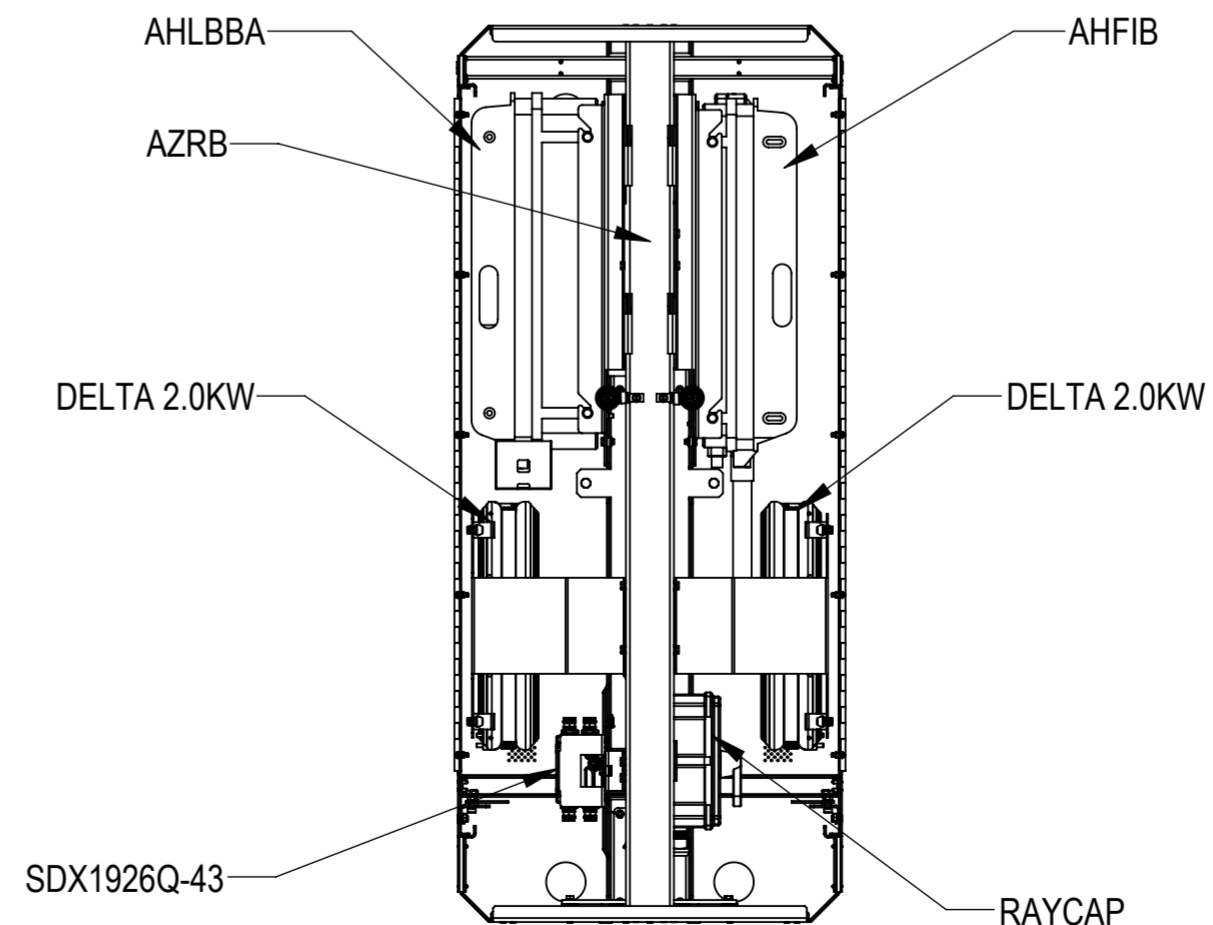

TOTAL INSTALLATION
THE FRONT DOOR IS HIDDEN FOR CLEAR VIEWING

COMMSCOPE, INC. OF NORTH CAROLINA				
TITLE				
760251532N-INSTALL				
SIZE	SCALE	DOCUMENT NO.		
A2	1:20	760251532N-INSTALL		
DRAWING				SHEET
VERSION	STATUS	REVISION	11 OF 11	
01	RE	B		