

TP-G412-96



Universal Tripod Mount, 4-1/2 in OD x 96 in pipe

Product Classification

Product Type Tripod mount

General Specifications

Mounting Surfaces

Note One 6 ft microwave antenna using 4-1/2 in pipe mast

Pipe, quantity 1

Dimensions

Height 2,438.4 mm | 96 in

Width 1524 mm | 60 in

Length 1.524 m | 5 ft

Pipe Length 2,438.4 mm | 96 in

Pipe Outer Diameter 114.3 mm | 4.5 in

TP-G412-96

Outline Drawing

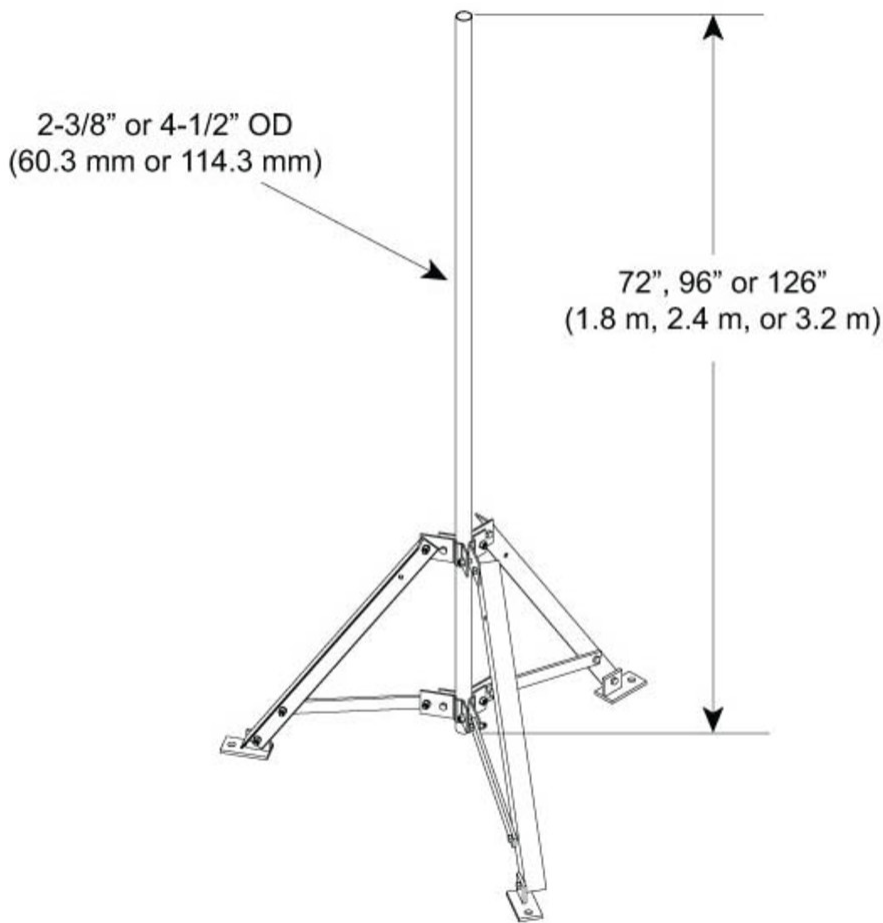

Material Specifications

Material Type Hot dip galvanized steel

Mechanical Specifications

Wind Rating 85 mph (BWS) at 100 ft AGL using Exposure C per UBC

Wind Rating Test Method TIA/EIA-222

Packaging and Weights

Included Mount, with or without pipe

Packaging quantity 1

TP-G412-96

Weight, net 117.9 kg | 259.925 lb

Regulatory Compliance/Certifications

| Agency | Classification |
|---------------|--|
| ISO 9001:2015 | Designed, manufactured and/or distributed under this quality management system |

Included Products

- MT-654-96 – Plain End Pipe, 4-1/2 in OD x 96 in x .188" A500C 46Ksi
- TP-G412-B – Universal Tripod Mount, base only, pipe not included

* Footnotes

Wind Rating BWS—Base Wind Speed; FBC—Florida Building Code

MT-654-96



Plain End Pipe, 4-1/2 in OD x 96 in x .188" A500C 46Ksi

Product Classification

Product Type Plain end pipe

General Specifications

Pipe, quantity 1

Dimensions

Height 114.3 mm | 4.5 in
Width 114.3 mm | 4.5 in
Length 2,438.4 mm | 96 in
Pipe Length 2,438.4 mm | 96 in
Pipe Outer Diameter 114.3 mm | 4.5 in
Material Thickness 4.775 mm | 0.188 in

Material Specifications

Material Type A500 | Hot dip galvanized steel
Material Grade C
Material Strength 46 KSI

Packaging and Weights

Included Pipe
Packaging quantity 1
Weight, net 31 kg | 68.343 lb

Regulatory Compliance/Certifications

| Agency | Classification |
|---------------|--|
| CHINA-ROHS | Above maximum concentration value |
| ISO 9001:2015 | Designed, manufactured and/or distributed under this quality management system |

MT-654-96

ROHS Compliant/Exempted

UK-ROHS Compliant/Exempted



TP-G412-B



Universal Tripod Mount, base only, pipe not included

Product Classification

Product Type Tripod mount

General Specifications

Mounting Surfaces

Note One 6 ft microwave antenna using 4-1/2 in pipe mast

Pipe, quantity 0

Dimensions

Height 838.2 mm | 33 in

Width 1524 mm | 60 in

Length 1.524 m | 5 ft

Pipe Length 0 mm | 0 in

Pipe Outer Diameter 114.3 mm | 4.5 in

TP-G412-B

Outline Drawing

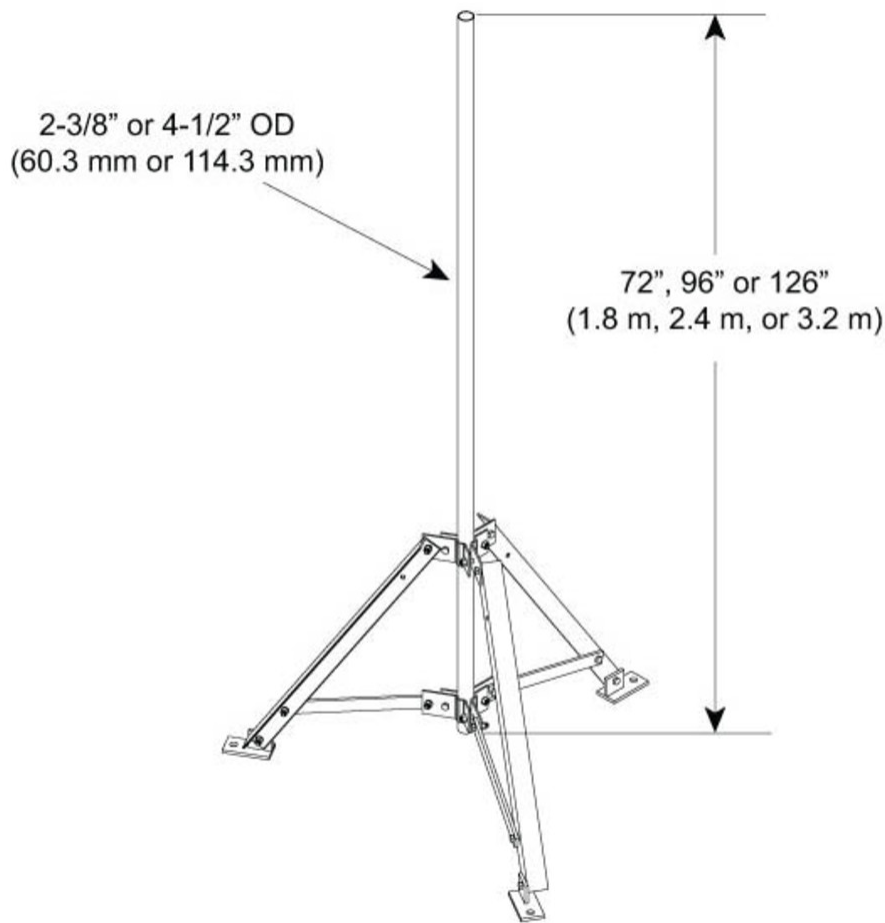

Material Specifications

Material Type Hot dip galvanized steel

Mechanical Specifications

Wind Rating 85 mph (BWS) at 100 ft AGL using Exposure C per UBC

Wind Rating Test Method TIA/EIA-222

Packaging and Weights

Included Mount, with or without pipe

Packaging quantity 1

TP-G412-B

Weight, net 78.7 kg | 173.504 lb

Regulatory Compliance/Certifications

| Agency | Classification |
|---------------|--|
| ISO 9001:2015 | Designed, manufactured and/or distributed under this quality management system |

* Footnotes

Wind Rating BWS—Base Wind Speed; FBC—Florida Building Code