

4

3

2

1

- 1.0 GENERAL NOTES
 1.1 ALL METRIC DIMENSIONS ARE IN BRACKETS [X.X]
 1.2 FOR PATENT INFO: <https://www.cs-pat.com>
- 2.0 DESIGN NOTES
 2.1 ANY HAZARDS OR OBSTRUCTIONS TO THE CLIMBING FACILITY AND SAFETY CLIMB MUST BE IDENTIFIED PRIOR TO INSTALLING THE APPURTENANCE. ADDITIONAL PRODUCTS MAY BE REQUIRED TO MAINTAIN THE INTEGRITY OF THE SAFETY CLIMB. DURING INSTALLATION, TEMPORARY AND/OR PERMANENT PRECAUTIONARY MEASURES SHOULD BE TAKEN TO PRESERVE THE CLIMBING FACILITY AND/OR SAFETY CLIMB.
 2.2 FITS MONOPOLES 20" TO 50" OD. MONOPOLE DIAMETER MUST BE GREATER THAN OR EQUAL TO 20" TO MEET ANTENNA TO ANTENNA CORNER SPACING OF >24".
- 3.0 MANUFACTURING/SPECIAL REQUIREMENTS
 3.1 TIGHTEN ALL BOLTS SECURING FLAT PLATES BY THE TURN-OF-NUT METHOD. TIGHTEN ALL U-BOLTS USING TURN-OF-NUT METHOD WITH ATTENTION TO LEAVE EQUAL DISTANCE AND EQUAL FORCE ON EACH LEG OF THE U-BOLT.
- 4.0 TEST
- 5.0 PACKAGING
 5.1 PACKAGING SHALL MEET COMMSCOPE REQUIREMENTS PER DOCUMENT IS-PL-3005.
 5.2 PRINTED DOCUMENT TO BE PLACED INSIDE POLYBAG AND THEN IN SHIPPING CONTAINER.
 5.3 EXTRA HARDWARE MAY BE SUPPLIED, BAGGED AND SHIPPED.

REVISIONS			
REV.	DESCRIPTION	DATE	APPROVED
A	INITIAL RELEASE	JL1183 07MAY24	CB1094 40194988CMO

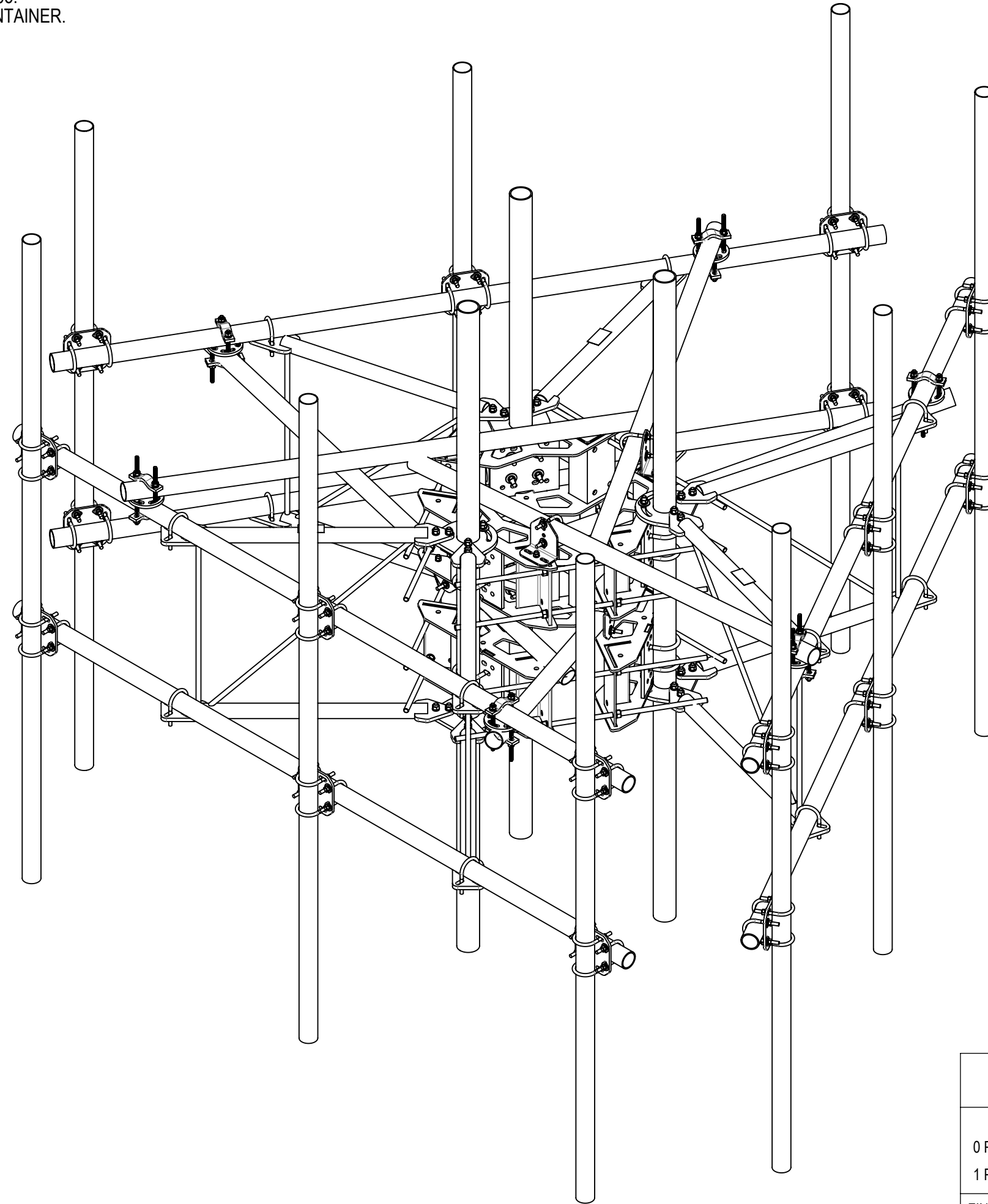

COMMSCOPE, INC. OF NORTH CAROLINA								
TOLERANCES		SAP MATERIAL MASTER						
0 PLACE X[X] ± 0.25[6.3]	2 PLACE .XX[X] ± 0.06[1.5]	MCG22RHDX-11M9120						
1 PLACE X[X] ± 0.12[3.0]	ANGLES ± 2°							
FINISH		MATERIAL						
<small>UNLESS OTHERWISE SPECIFIED DIMENSIONS ARE IN INCHES INTERPRET PER ANSI Y 14.5M-1994</small>		NAME	DATE	PG,MP,SF,11'FP,(09)120"AP				
		CE JL1183	07MAY24					
		RW JL1183	05/16/2024	SCALE 1:20	DOCUMENT NO. MCG22RHDX-11M9120			
		AD CB1094	05/22/2024					
		RE JL1183	05/23/2024					
ECN 40194988CMO								
SIZE	Auth Group	INSL	MODEL		DRAWING			SHEET 1 OF 4
C			VERSION	STATUS	REVISION	VERSION	STATUS	
			00	RE	A	00	RE	A

DENSITY		lbs/in ³
MASS	2095.59	lbs
VOLUME	8328.46	in ³
SURFACE AREA	79131.00	in ²
HEIGHT	120"	
LENGTH	132"	
WIDTH	84"	

4

3

2

1

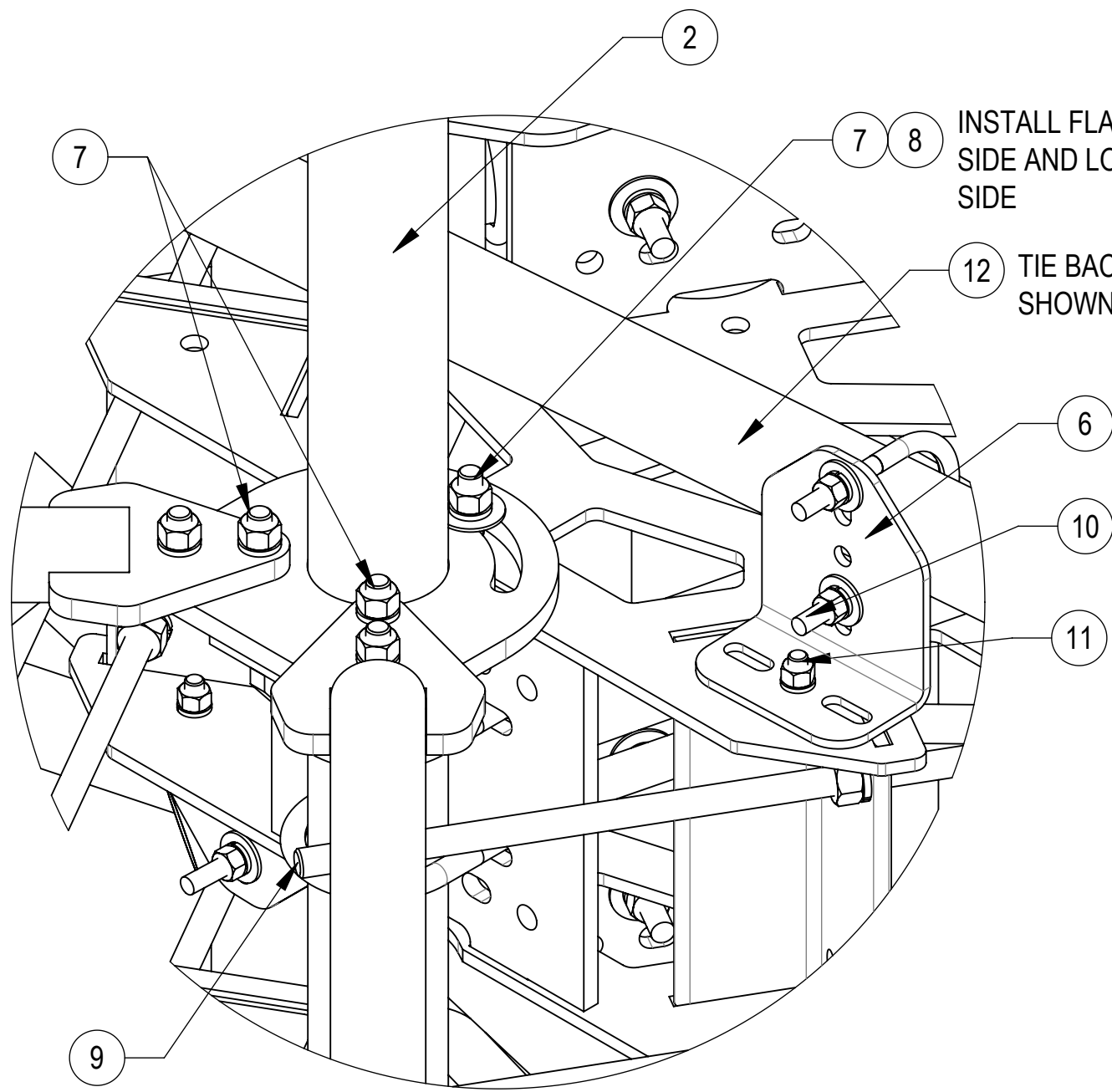

DETAIL B
SCALE 1:4

INSTALL FLAT WASHER ON NEAR SIDE AND LOCK WASHER ON FAR SIDE
TIE BACK PIPE POSITION IS ONLY SHOWN AS REFERENCE

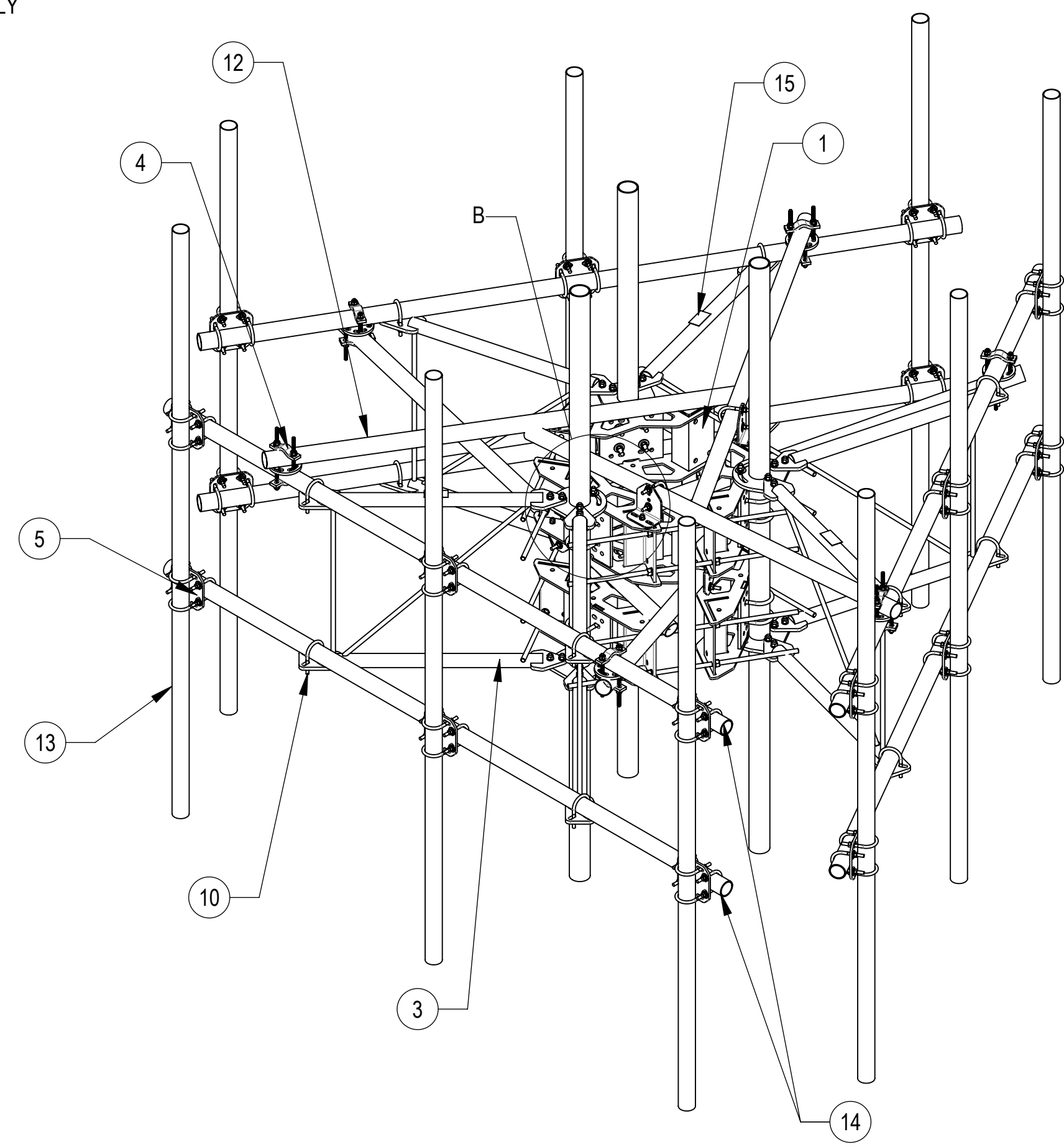

TOP
BOTTOM

COMPONENT PART NUMBERS PROVIDED FOR ASSEMBLY PURPOSES;
INDIVIDUAL COMPONENTS MAY BE SHIPPED AS PARTS WITHIN AN INCLUDED KIT.

ITEM	PART NO.	DESCRIPTION	QTY.	WEIGHT	NOTE NO.
1	MC-RM1550-3	15" - 50" OD RINGMOUNT	2	229.90 LBS	
2	SFG2204	WELDMENT, BACK VERTICAL ARM MOUNT	3	36.96 LBS	
3	SFG2278	ARM, STANDOFF - SFG22	6	40.92 LBS	
4	XP-R	CROSSOVER PLATE, ROUND, UP TO 3.5" OD	6	6.20 LBS	
5	XP-2525	CROSSOVER PLATE KIT, 2-7/8 OD X 2-7/8 OD	18	8.37 LBS	
6	XAU01	ANGLE, CROSSOVER, 1.9-3.5" X 1.9-3.5" OD	6	2.98 LBS	
7	GB-05225	5/8" X 2-1/4" GALV BOLT KIT	30	0.28 LBS	
8	GWF-05	5/8" GALV FLAT WASHER, 1.7OD	6	0.06 LBS	
9	GUB-53560	5/8" X 3-5/8" X 6" GALV U-BOLT	12	1.30 LBS	
10	GUB-4352	1/2" X 3" X 5-1/4" GALV U-BOLT	18	0.71 LBS	
11	GB-04145	1/2" X 1-1/2" GALV BOLT KIT	6	0.13 LBS	
12	MT546084120	2.88" OD X 84" LONG PIPE	6	24.81 LBS	
13	MT546120120	PIPE, 2.875"OD X 120"	9	35.44 LBS	
14	MT546132	2.875" O.D. X 132" PIPE	6	62.64 LBS	
15	SFG2295	LABEL, SFG22RHDX	3	0.04 LBS	

ALLOWABLE TIEBACK ANGLE
±15 DEGREES VERTICAL
±25 DEGREES HORIZONTAL

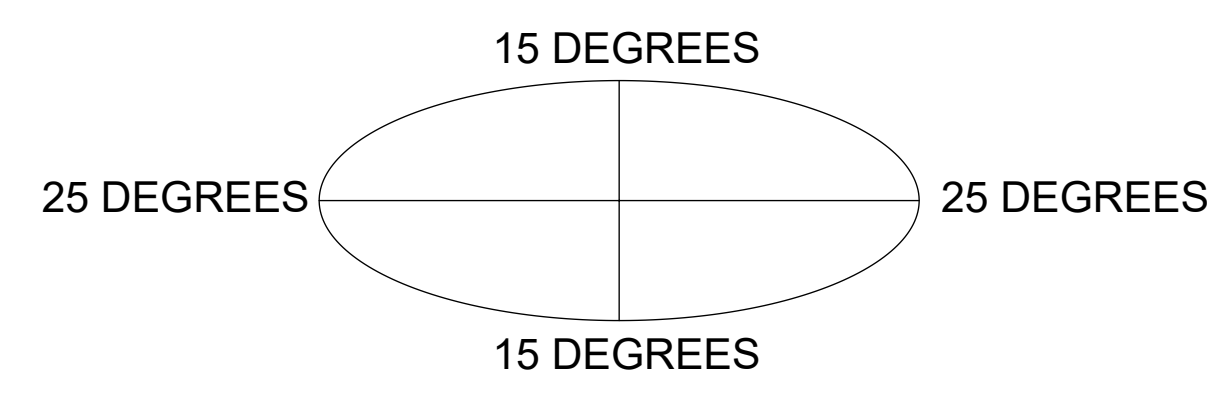

COMMSCOPE, INC. OF NORTH CAROLINA			
TITLE PG,MP,SF,11'FP,(09)120"AP			
SIZE C	SCALE 1:20	DOCUMENT NO. MCG22RHDX-11M9120	
DRAWING		VERSION	STATUS
REVISION		00	RE
SHEET		REVISION	A
2 OF 4			

4

3

2

1

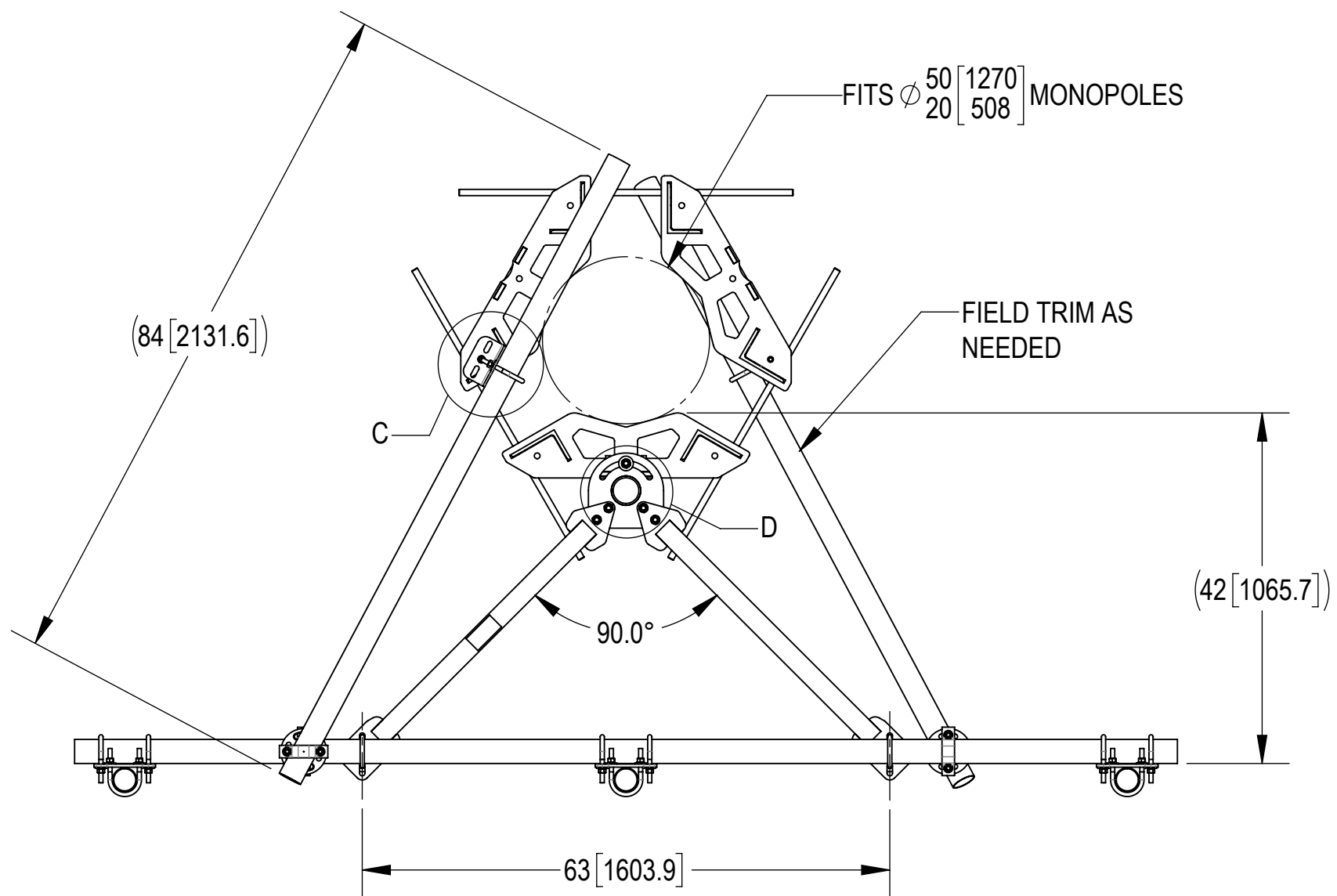

ALLOWABLE TIEBACK ANGLE

±15 DEGREES VERTICAL
±25 DEGREES HORIZONTAL

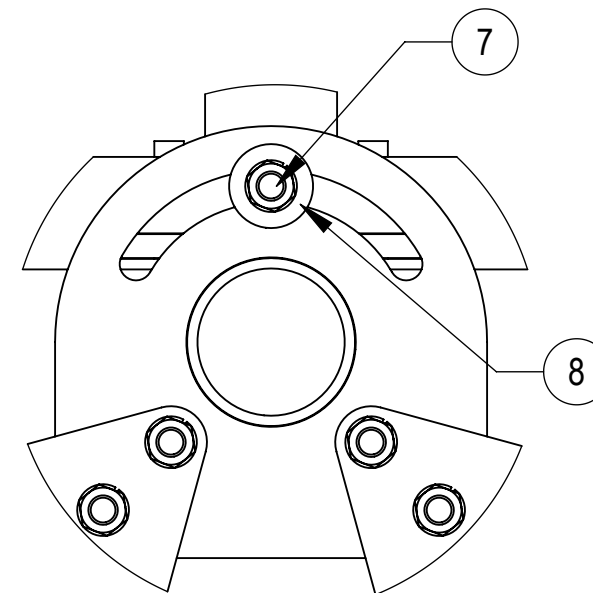
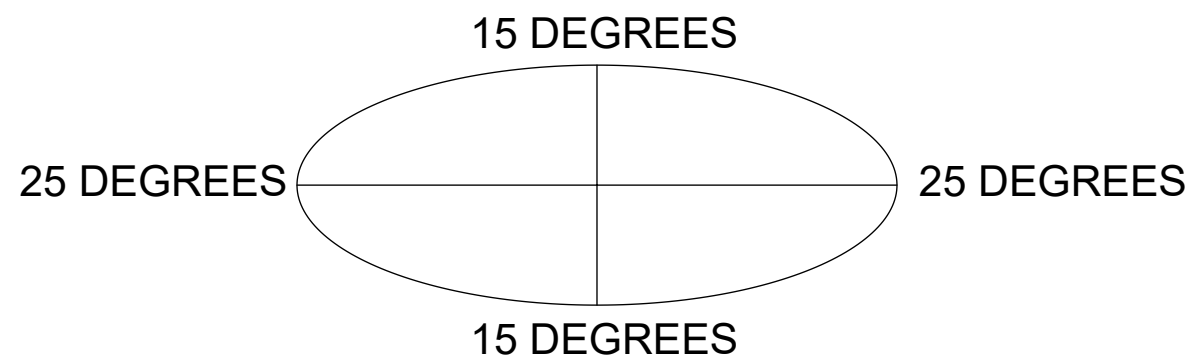

DETAIL D
SCALE 1:4

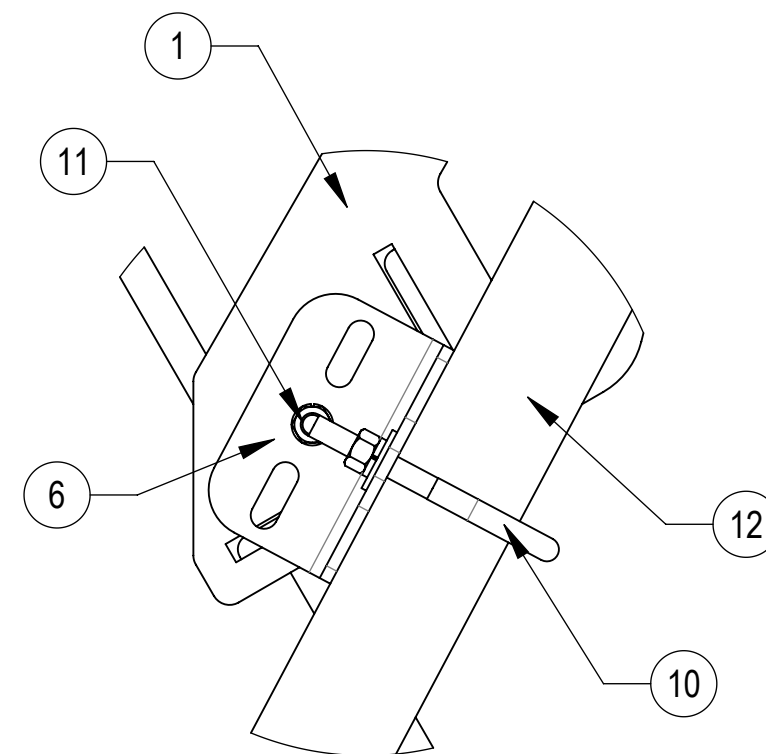

DETAIL C
SCALE 1:4

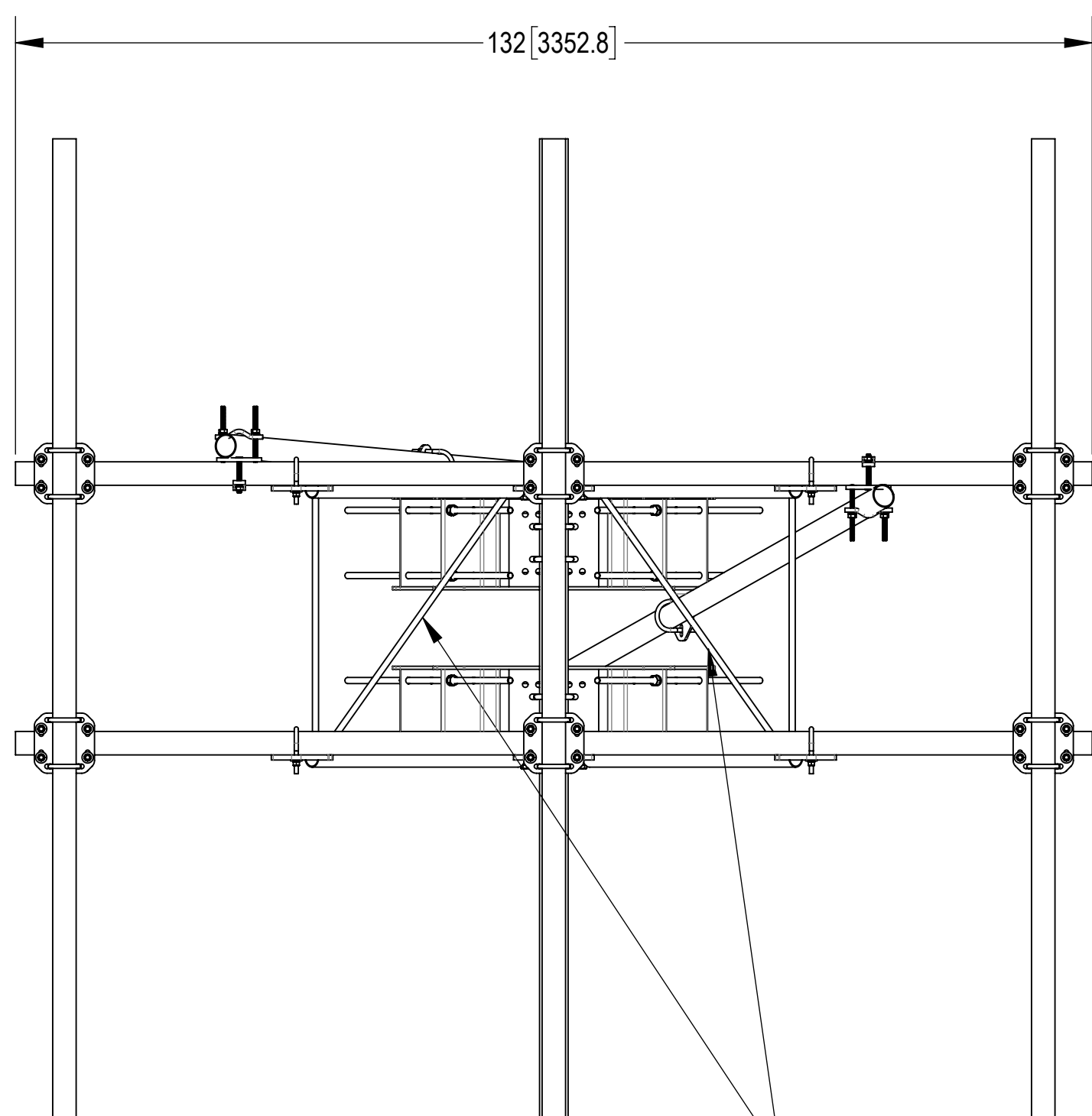

TOP
BOTTOM

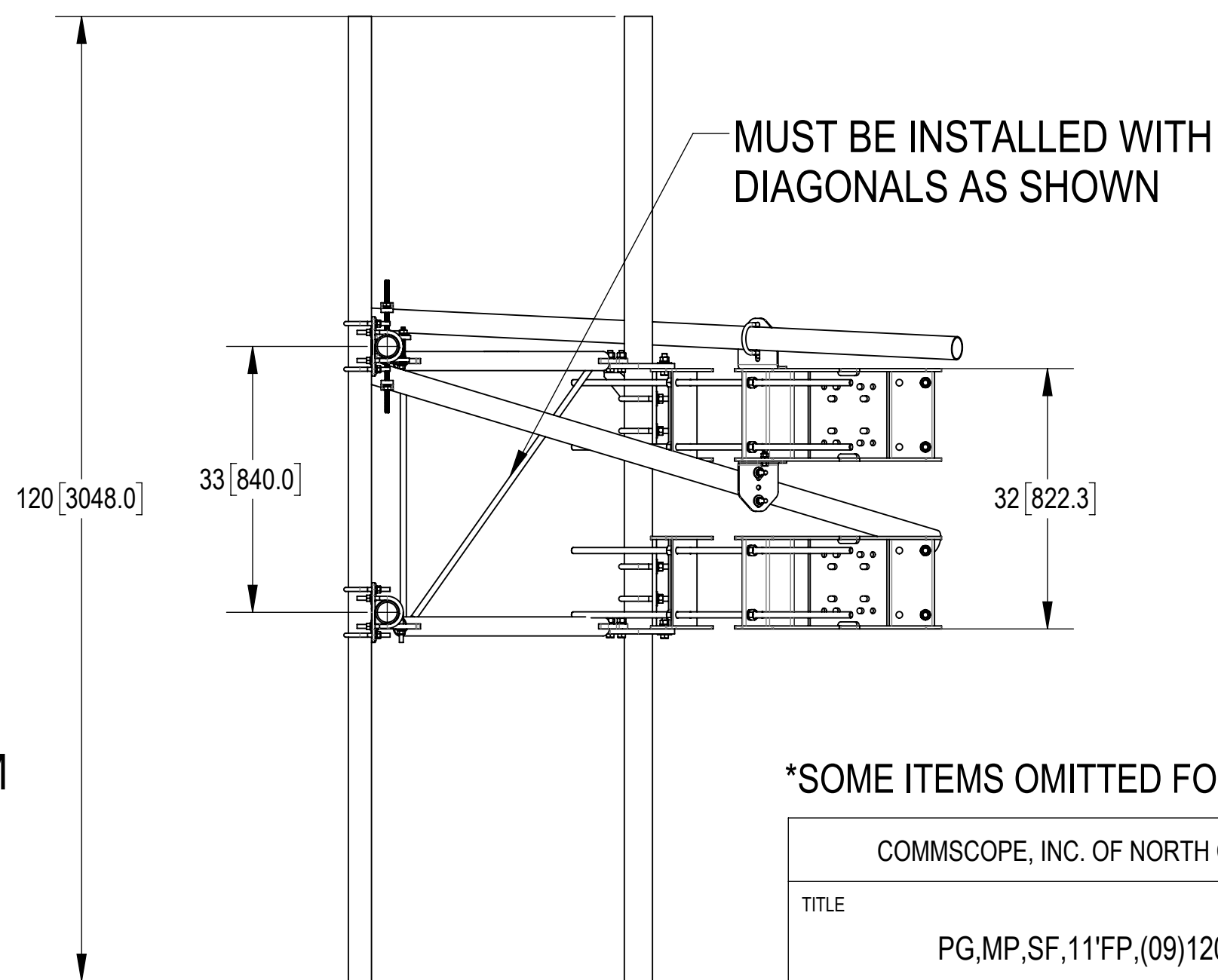

SOME ITEMS OMITTED FOR CLARITY

COMMSCOPE, INC. OF NORTH CAROLINA				
TITLE PG,MP,SF,11'FP,(09)120"AP				
SIZE C	SCALE 1:20	DOCUMENT NO. MCG22RHDX-11M9120		
		DRAWING		SHEET
		VERSION	STATUS	REVISION
		00	RE	A
				3 OF 4

4

3

2

1

ANTENNA SPACING SHOWN

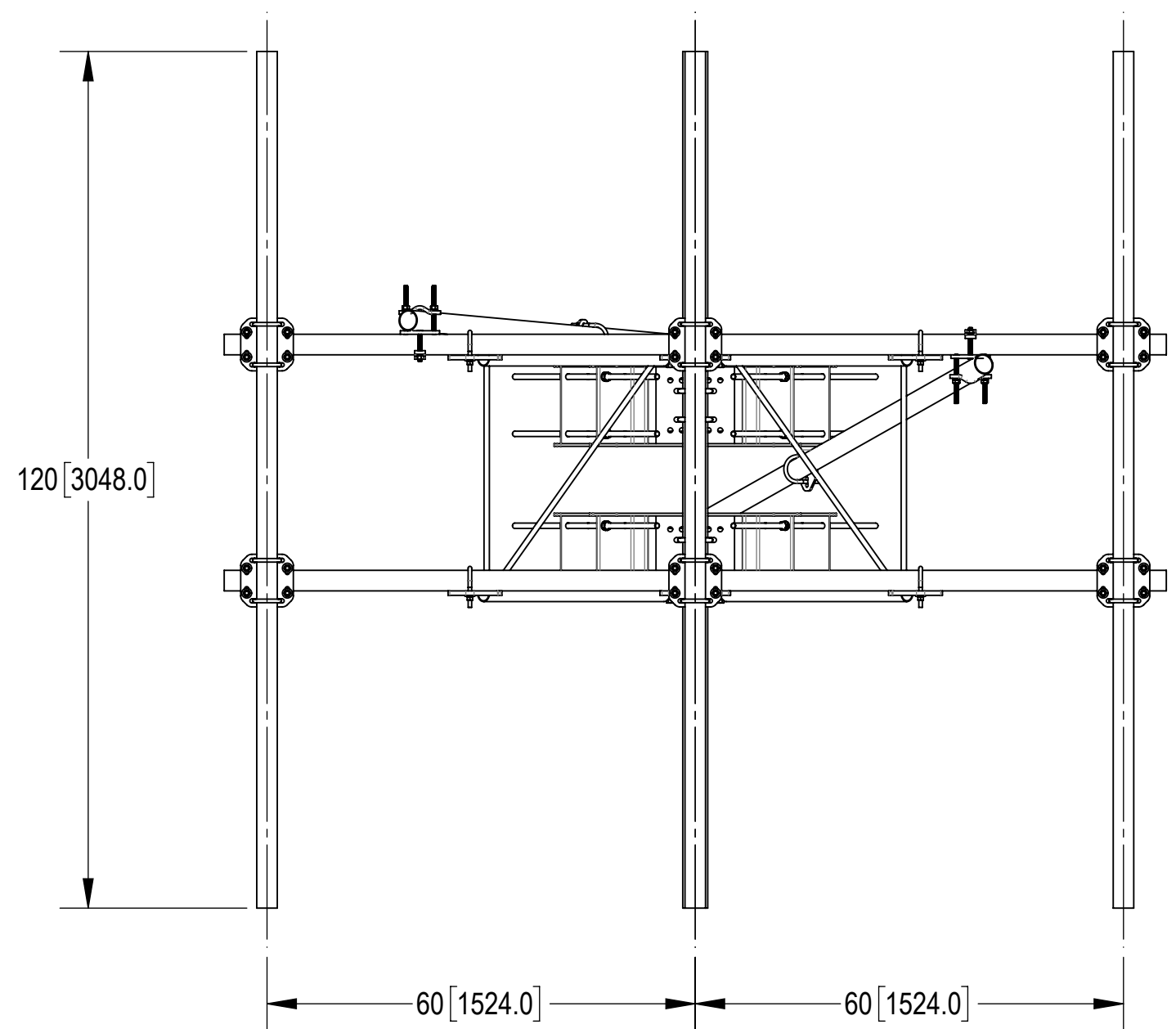
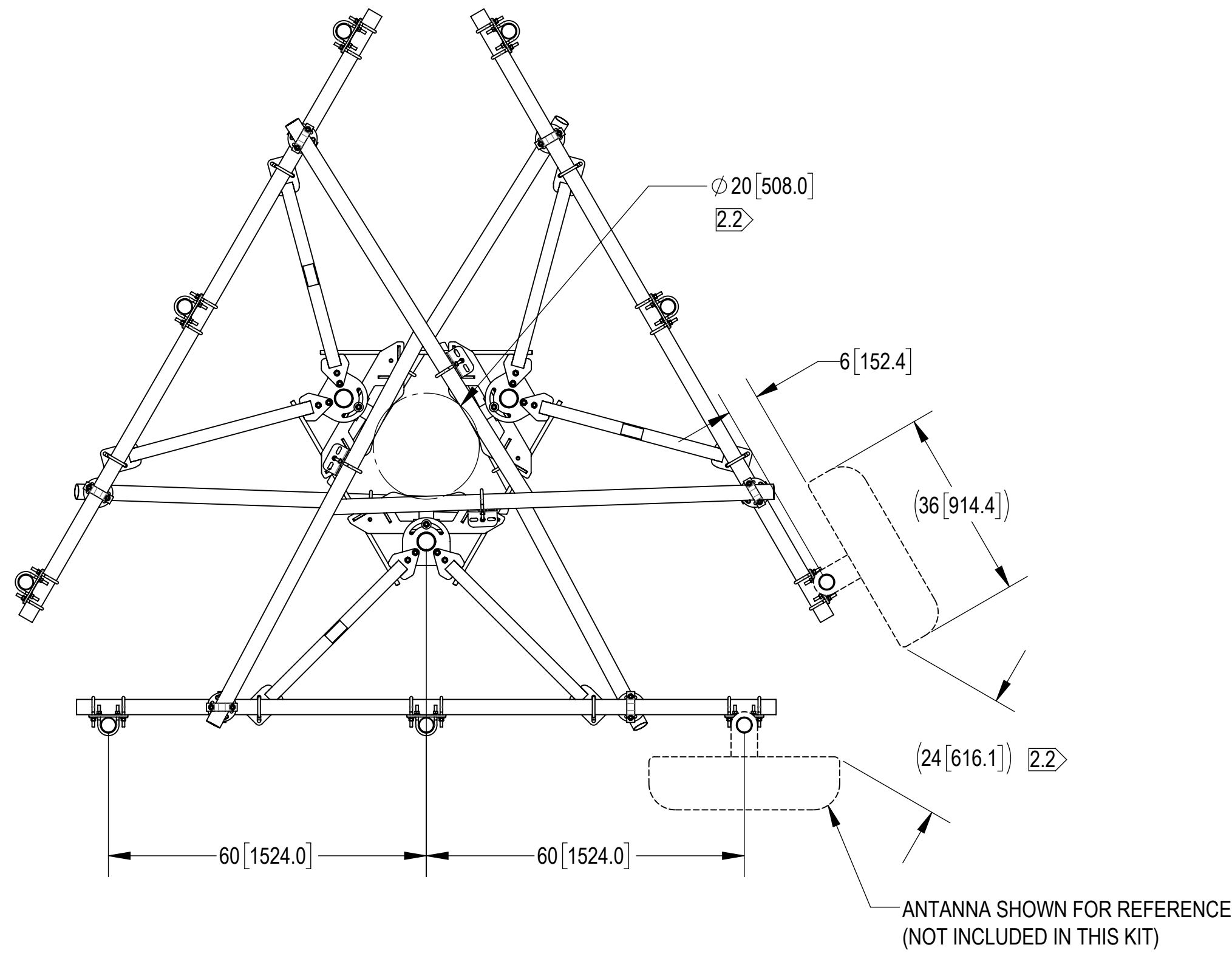

SOME ITEMS OMITTED FOR CLARITY

COMMSCOPE, INC. OF NORTH CAROLINA				
TITLE PG,MP,SF,11'FP,(09)120"AP				
SIZE C	SCALE 1:24	DOCUMENT NO. MCG22RHDx-11M9120		
		DRAWING		SHEET
		VERSION	STATUS	REVISION
		00	RE	A
				4 OF 4