

REVISIONS			
REV	CMO	DATE	APPROVED
A	40177787CMO	22-AUG-2023	A.MAYA

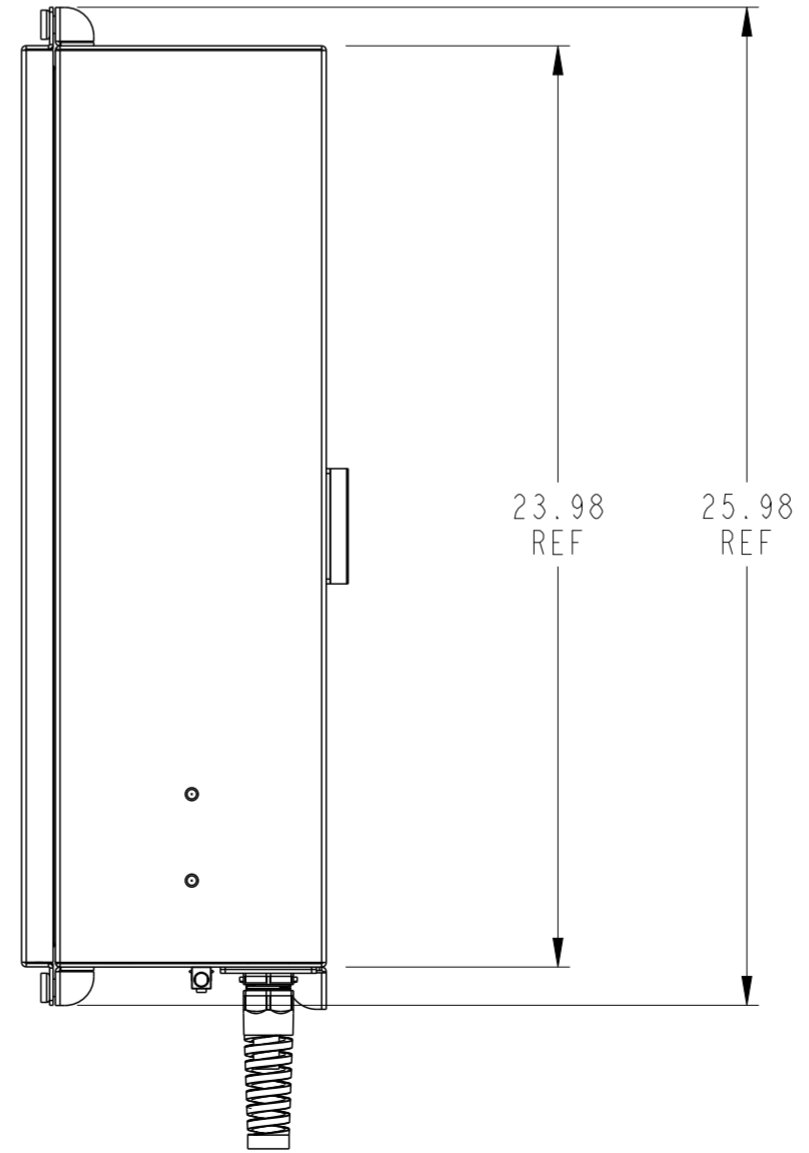
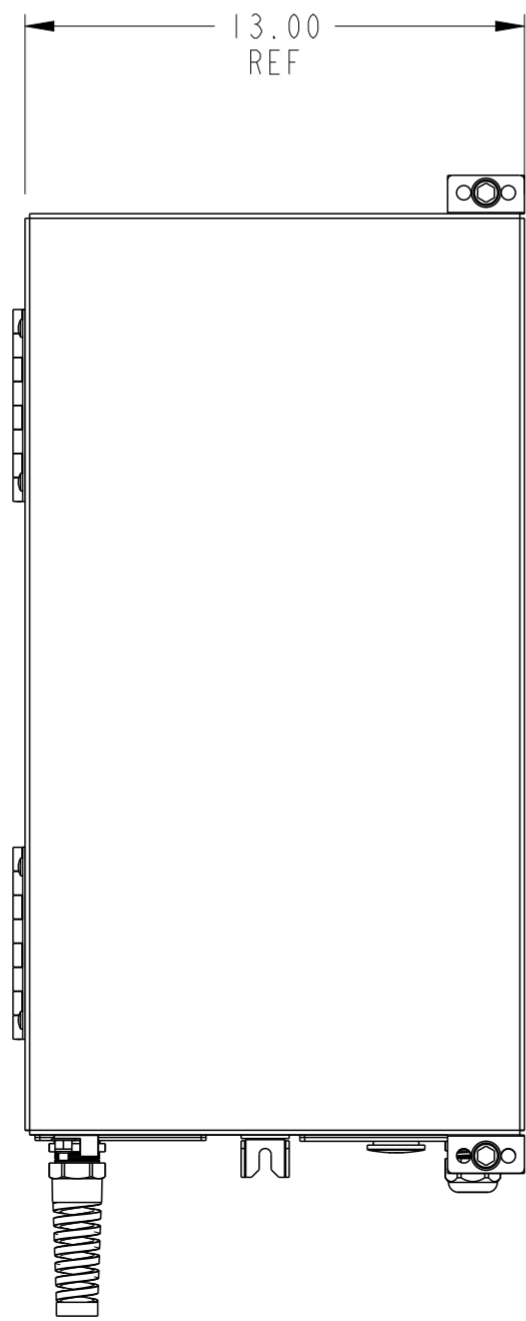
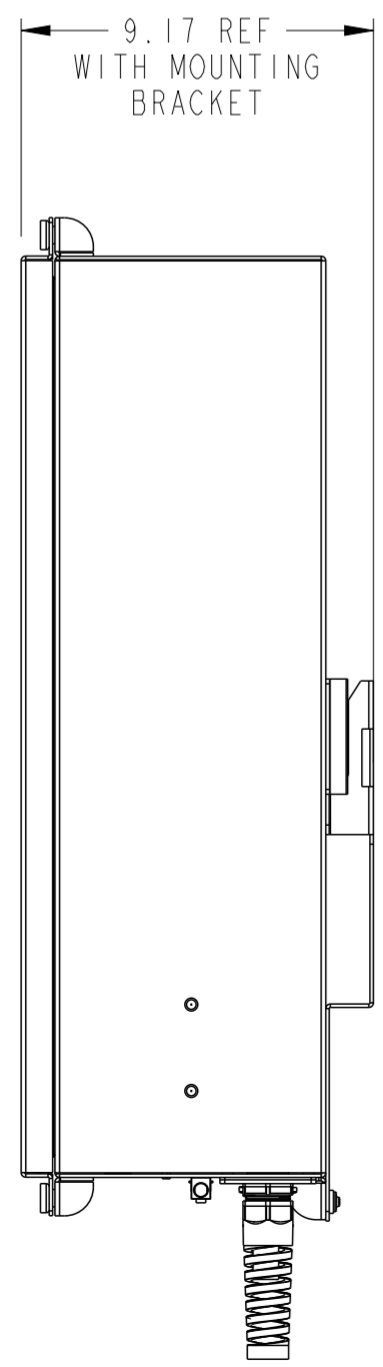
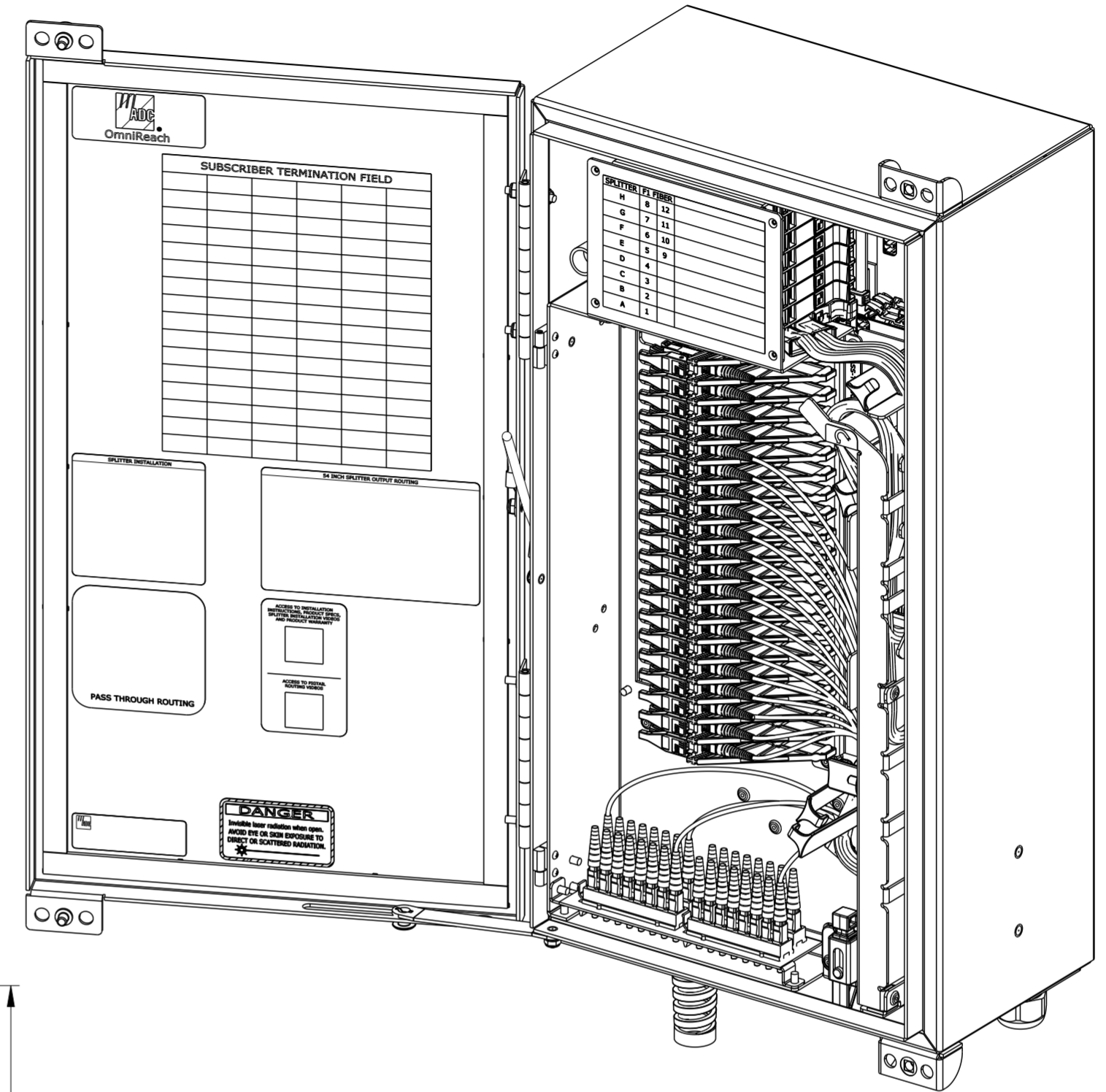
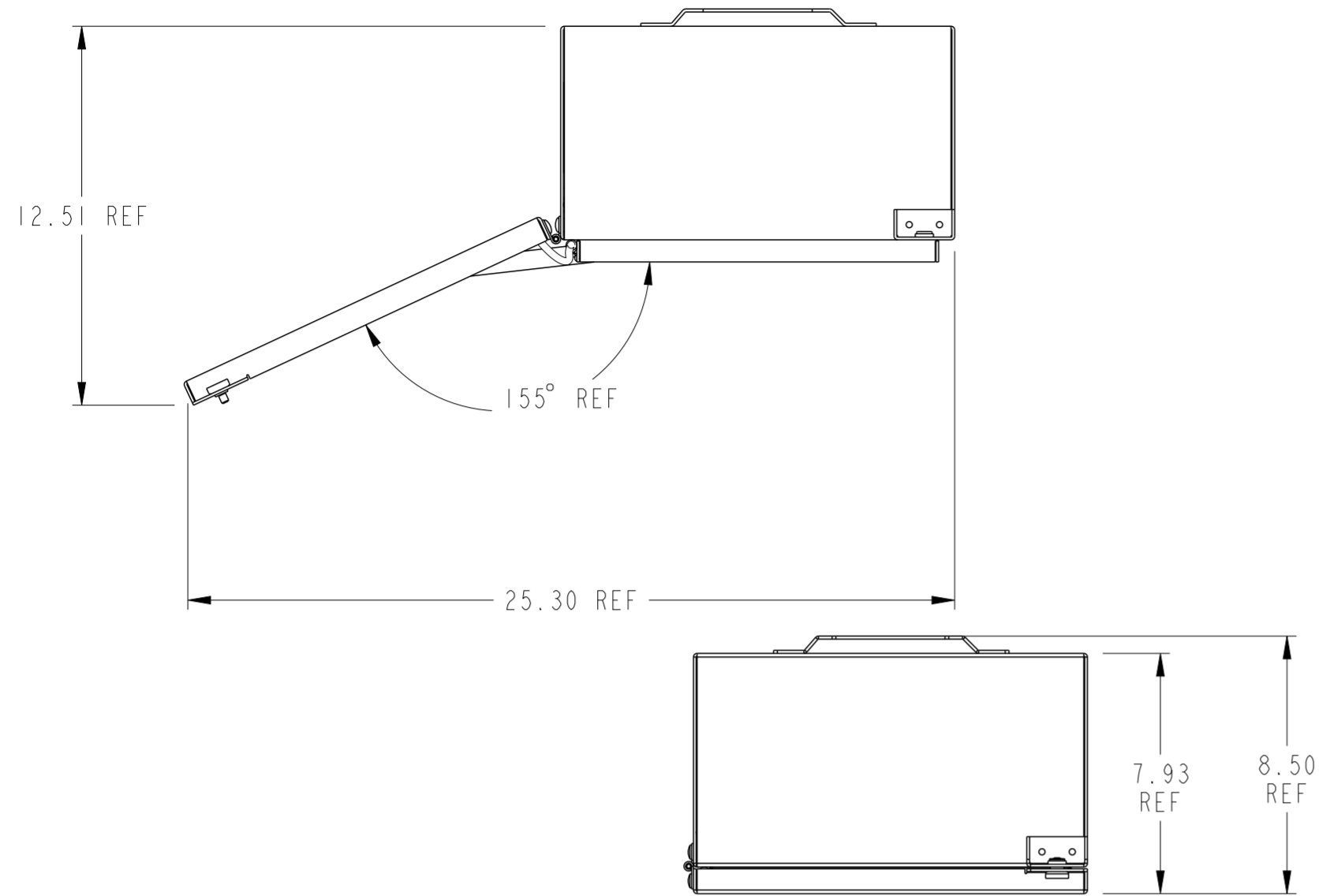

COMMSCOPE, INC.										
TOLERANCES					SAP MATERIAL MASTER					
SEE TABLE										
FINISH					MATERIAL					
SEE NOTES					SEE NOTES					
SYMBOLS AGREE WITH ASME Y14.5M - 2009. ALL SHEETS ARE THE SAME REVISION AND STATUS.	DRAFTER			TITLE						
	O. BARRIENTOS			MINI FDH, INSTALLATION DRW						
	CHECKER			SIZE		SCALE		DOCUMENT NO.		
	A. MAYA			A2		0.125		860638095		
ENGINEER			CMO							
A. MAYA			40177787CMO							
ALL SURFACES		WORK AREA: NCC		MODEL		DRAWING		SHEET		
✓		⊕		00		00		RE A		
								1 OF 4		

© 2024 CommScope, Inc. Confidential
 NOTICE: These drawings and specifications are the proprietary property of COMMSCOPE, INC. and may be used only for the specific purpose authorized in writing by COMMSCOPE, INC.

54 INCH SPLITTER CABLE ROUTING

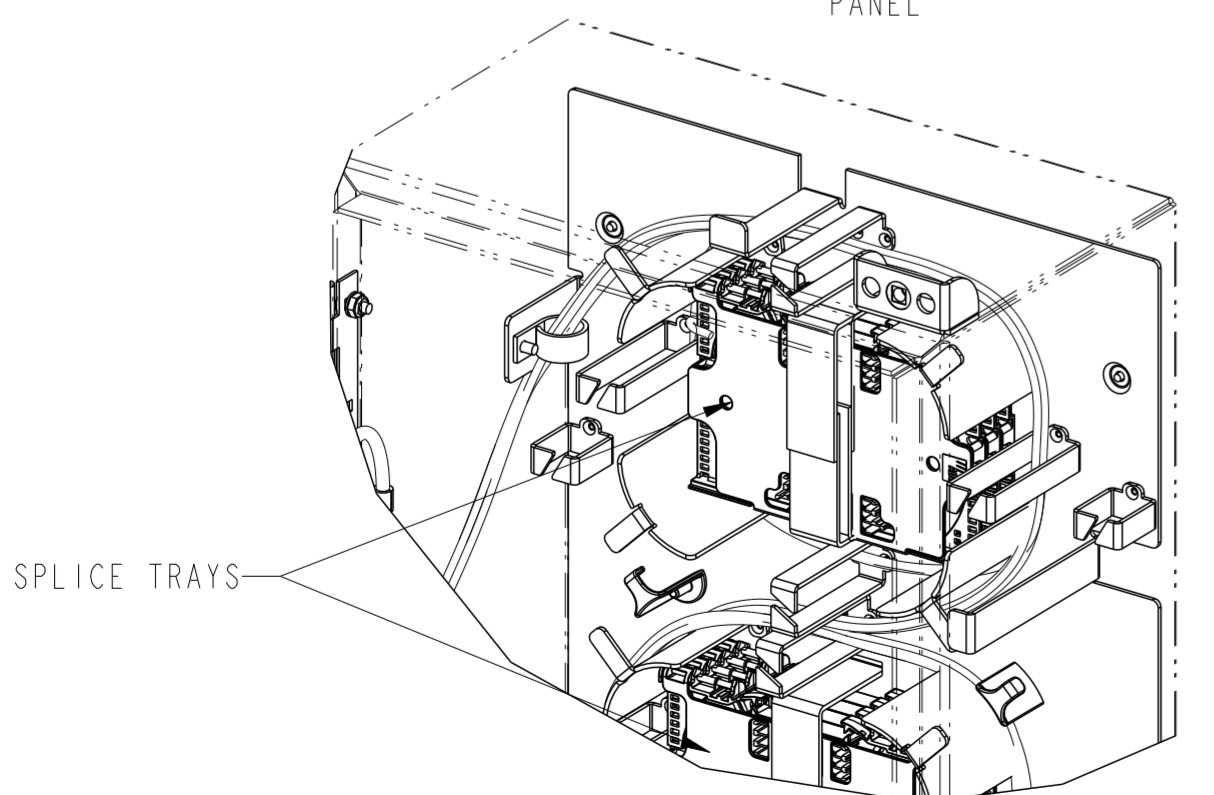
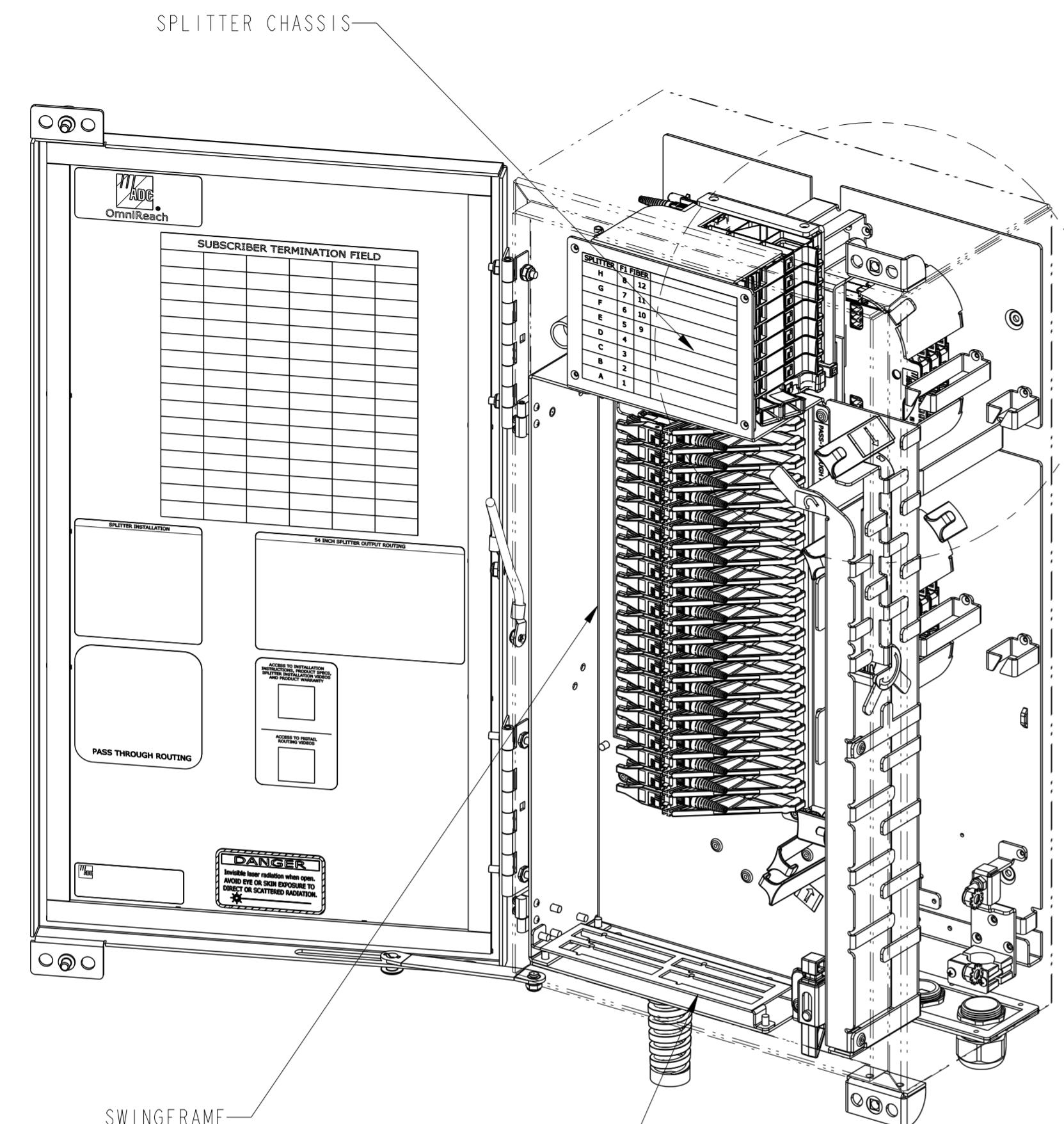

DETAIL A
(SPLICE VERSION CABINET SHOWN WITH OPENED SWINGFRAME FOR REFERENCE ONLY)

FEEDER CABLE ASSIGNMENTS

FIBERS 1-8	SPLITTER SLOTS 1-8
FIBERS 9-12	SPLITTER SLOTS 5-8 (SECOND COLUMN OF SPLITTER INPUTS)
FIBERS 13-36 (IF APPLICABLE)	PASS-THROUGH PORTS 13-36

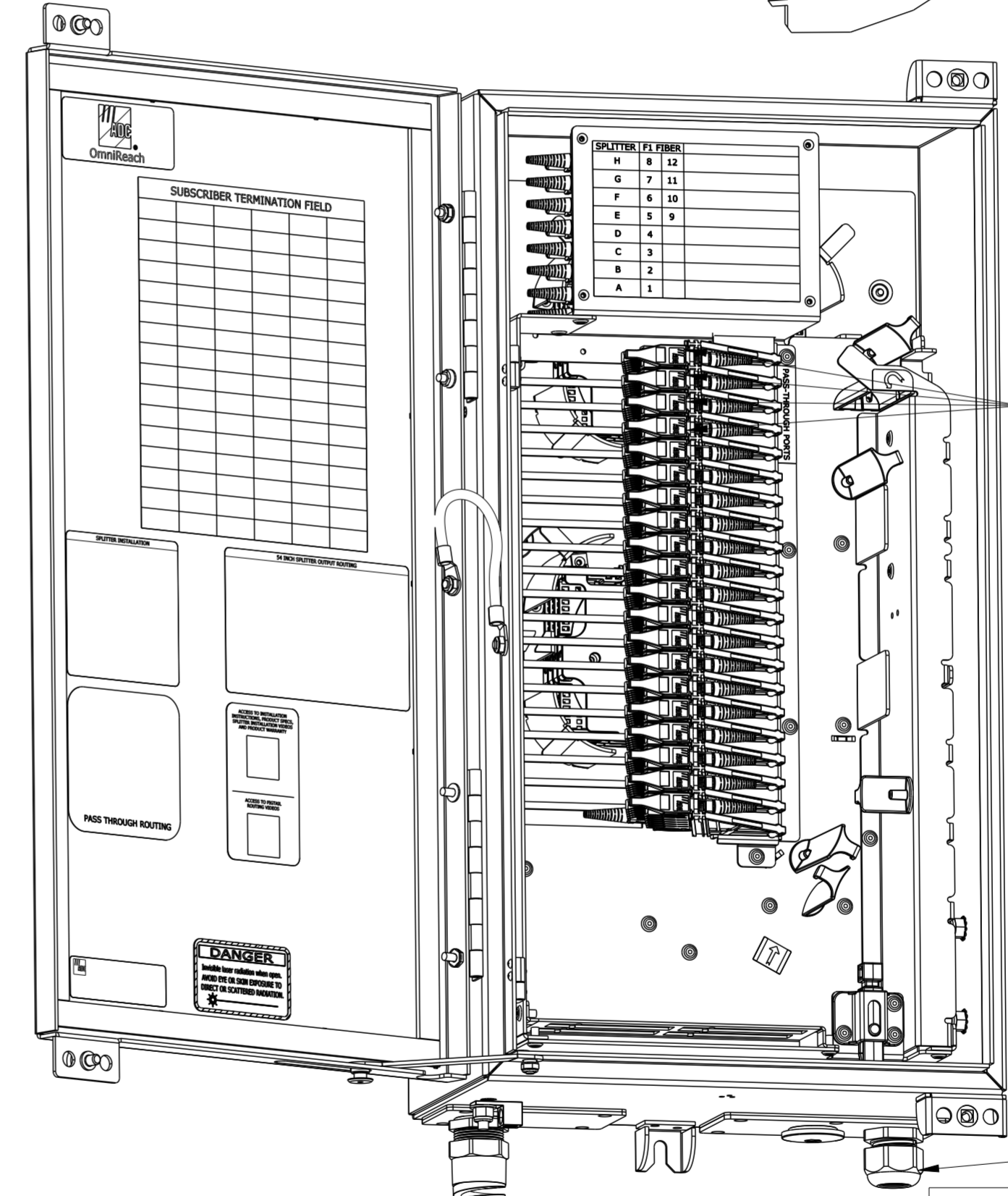
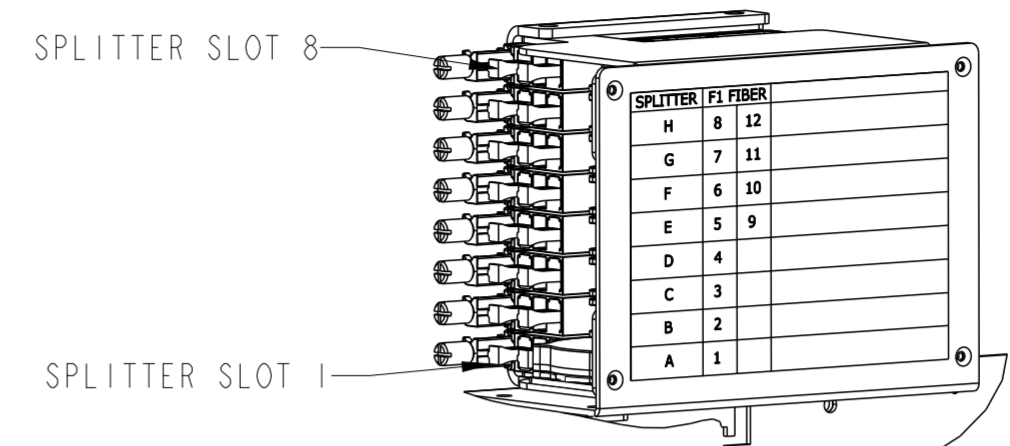

DISTRIBUTION STRAIN RELIEF FOR CABLES THAT ARE 0.35 TO 0.63 INCHES IN DIAMETER

DISTRIBUTION STRAIN RELIEF FOR CABLES THAT ARE 0.51 TO 0.71 INCHES IN DIAMETER

COMMSCOPE, INC.			
TITLE MINI FDH, INSTALLATION DRW			
SIZE A2	SCALE 0.100	DOCUMENT NO. 860638095	
DRAWING VERSION STATUS REVISION			SHEET 2 OF 4
00	RE	A	

© 2024 CommScope, Inc. Confidential
NOTICE: These drawings and specifications are the proprietary property of COMMSCOPE, INC. and may be used only for the specific purpose authorized in writing by COMMSCOPE, INC.

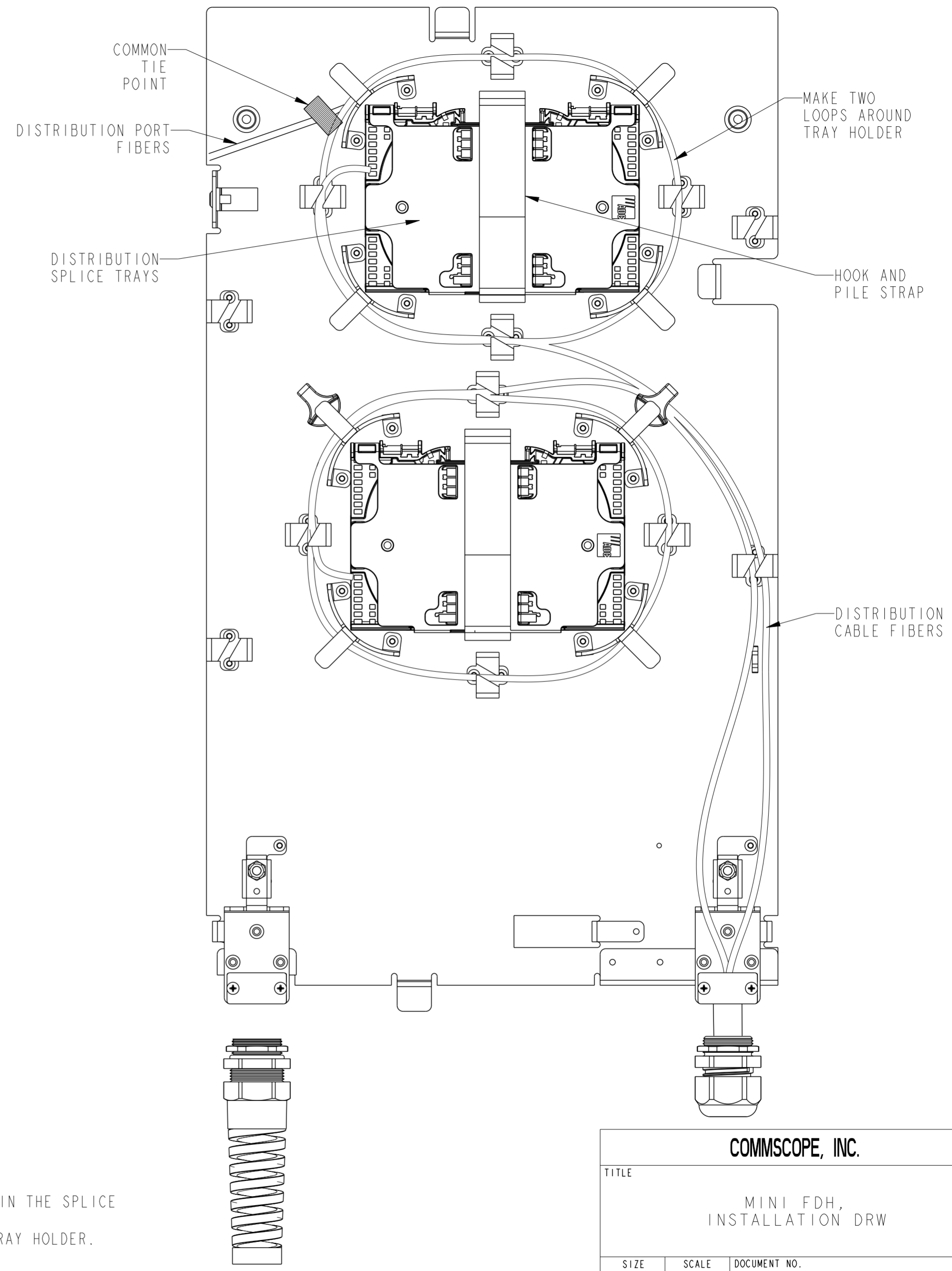
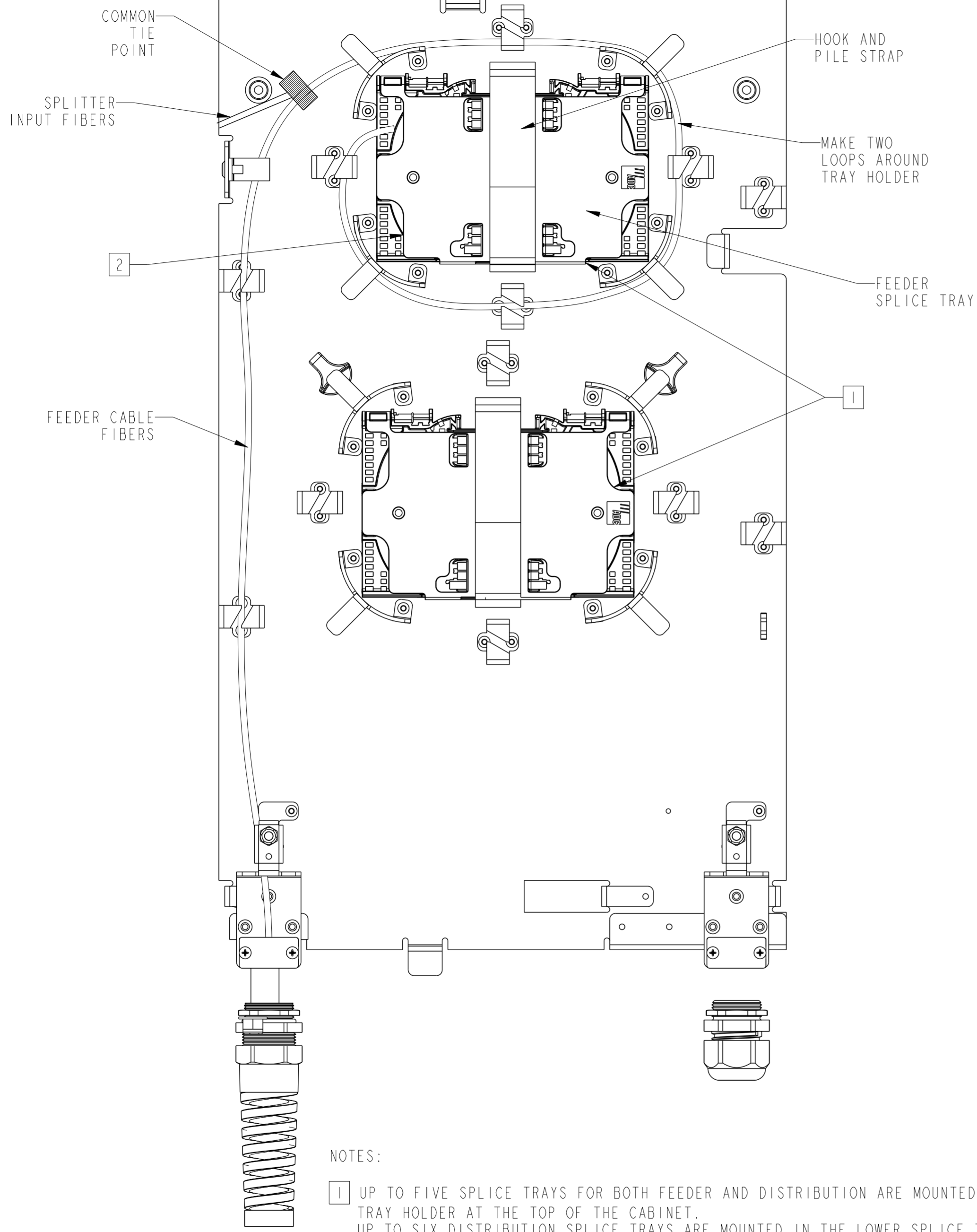

NOTES:

1 UP TO FIVE SPLICE TRAYS FOR BOTH FEEDER AND DISTRIBUTION ARE MOUNTED IN THE SPLICE TRAY HOLDER AT THE TOP OF THE CABINET. UP TO SIX DISTRIBUTION SPLICE TRAYS ARE MOUNTED IN THE LOWER SPLICE TRAY HOLDER. REFER TO IDENTIFICATION LABEL ON EACH SPLICE TRAY.

COMMSCOPE, INC.			
TITLE MINI FDH, INSTALLATION DRW			
SIZE A2	SCALE 0.100	DOCUMENT NO. 860638095	
DRAWING			SHEET
VERSION STATUS REVISION			3 OF 4
00 RE A			

© 2024 CommScope, Inc. Confidential
 NOTICE: These drawings and specifications are the proprietary property of COMMSCOPE, INC. and may be used only for the specific purpose authorized in writing by COMMSCOPE, INC.

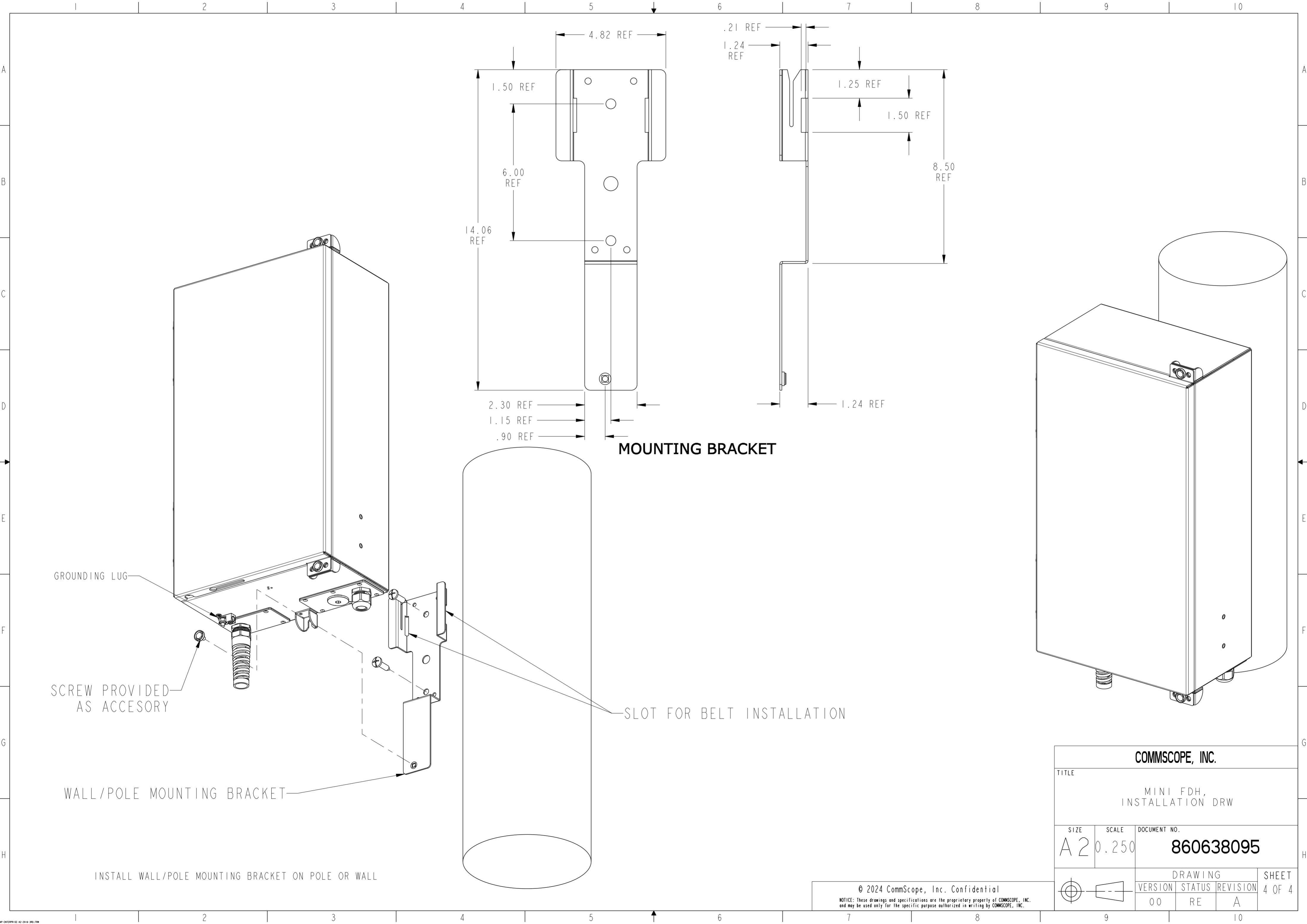

COMMSCOPE, INC.

TITLE
MINI FDH,
INSTALLATION DRW

SIZE	SCALE	DOCUMENT NO.
A2	0.250	860638095

DRAWING			SHEET 4 OF 4
VERSION	STATUS	REVISION	
00	RE	A	

© 2024 CommScope, Inc. Confidential
NOTICE: These drawings and specifications are the proprietary property of COMMSCOPE, INC. and may be used only for the specific purpose authorized in writing by COMMSCOPE, INC.

