

- 1.0 GENERAL NOTES
- 1.1 ALL METRIC DIMENSIONS ARE IN BRACKETS [X.X]
- 1.2 FOR PATENT INFO: <https://www.cs-pat.com>

- 2.0 DESIGN NOTES
- 2.1 ANY HAZARDS OR OBSTRUCTIONS TO THE CLIMBING FACILITY AND SAFETY CLIMB MUST BE IDENTIFIED PRIOR TO INSTALLING THE APPURTENANCE. ADDITIONAL PRODUCTS MAY BE REQUIRED TO MAINTAIN THE INTEGRITY OF THE SAFETY CLIMB. DURING INSTALLATION, TEMPORARY AND/OR PERMANENT PRECAUTIONARY MEASURES SHOULD BE TAKEN TO PRESERVE THE CLIMBING FACILITY AND/OR SAFETY CLIMB.

- 2.2 UP TO 5.0° TAPER AVAILABLE ON MODELS THAT SUPPORT ADJUSTMENT

- 3.0 MANUFACTURING/SPECIAL REQUIREMENTS
- 3.1 TIGHTEN ALL BOLTS SECURING FLAT PLATES BY THE TURN-OF-NUT METHOD. TIGHTEN ALL U-BOLTS USING TURN-OF-NUT METHOD WITH ATTENTION TO LEAVE EQUAL DISTANCE AND EQUAL FORCE ON EACH LEG OF THE U-BOLT.

- 4.0 TEST

- 5.0 PACKAGING
- 5.1 PACKAGING SHALL MEET COMMSCOPE REQUIREMENTS PER DOCUMENT IS-PL-3005.
- 5.2 PRINTED DOCUMENT TO BE PLACED INSIDE POLYBAG AND THEN IN SHIPPING CONTAINER.
- 5.3 EXTRA HARDWARE MAY BE SUPPLIED, BAGGED AND SHIPPED.

REVISIONS			
REV.	DESCRIPTION	DATE	APPROVED
A	INITIAL RELEASE	YMENG 08OCT23	YW1047 40179448CMO
B	ADDED SFG23RHDXL12-4-96, SFG23RHDXL14-4-96, SFG23RHDXL14-4-126, SFG23RHDXL14-5-96 AND SFG23RHDXL14-5-126 TO SERIES	RY1002 22NOV23	YC1015 40183018CMO
C	ADDED SFG23RHDXL11-3-96, SFG23RHDXL12-4-126, SFG23RHDXL13-4-96, SFG23RHDXL15-4-96 AND SFG23RHDXL15-5-96 TO SERIES	RY1002 11DEC23	YC1015 40182550CMO
D	CHG PALLET FROM QVPALLET TO 74X38PALLET; UPDATED SFG23180-00 TO ADD UNIVERSAL INTERFACE PLATES	RY1002 25JUL24	XK1001 40200655CMO

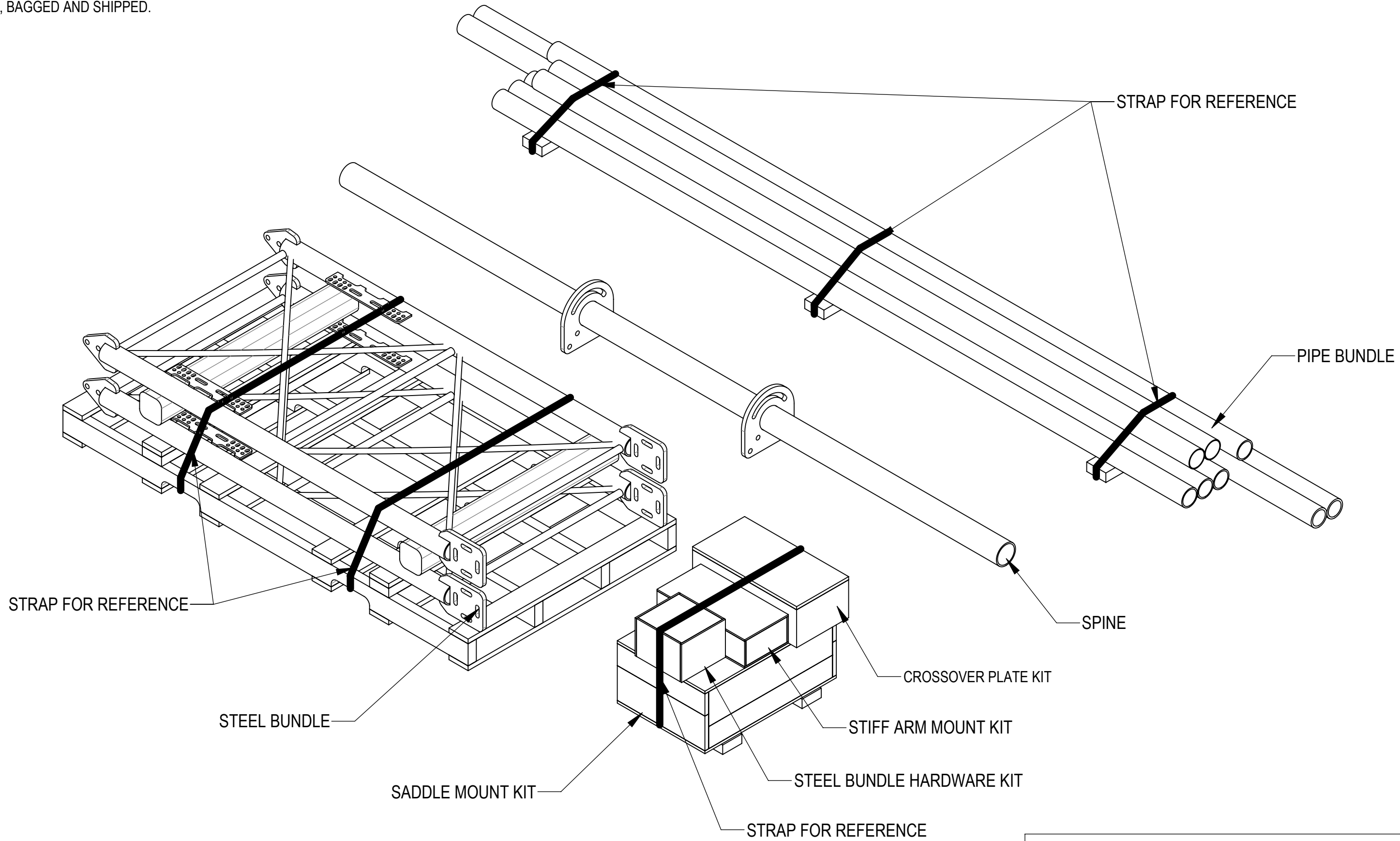

COMMSCOPE, INC. OF NORTH CAROLINA													
TOLERANCES						SAP MATERIAL MASTER							
1 PLACE .X[X] ± 0.2[6.3]			3 PLACE .XXX[X] ± 0.060[1.5]			SEE TABLE 1							
2 PLACE .XX[X] ± 0.12[3.0]			ANGLES ± 2°										
FINISH						MATERIAL							
<small>UNLESS OTHERWISE SPECIFIED DIMENSIONS ARE IN INCHES INTERPRET PER ANSI Y 14.5M-1994</small>						NAME		DATE		TITLE			
						CE YMENG		08OCT23		SFG23RHDXL SECTOR FRAME SERIES			
						RW RY1002		07/29/2024					
						AD XK1001		08/01/2024		SCALE		DOCUMENT NO.	
						RE RY1002		08/14/2024		1:32		SFG23RHDXL	
ECN 40200655CMO													
SIZE		Auth Group		INSL		MODEL			DRAWING				
C		⊕		◁		VERSION			STATUS				
						04			RE				
						E			03				
						RE			D				
									1 OF 12				

DENSITY	lbs/in ³
MASS	lbs
VOLUME	in ³
SURFACE AREA	in ²
HEIGHT	
LENGTH	
WIDTH	

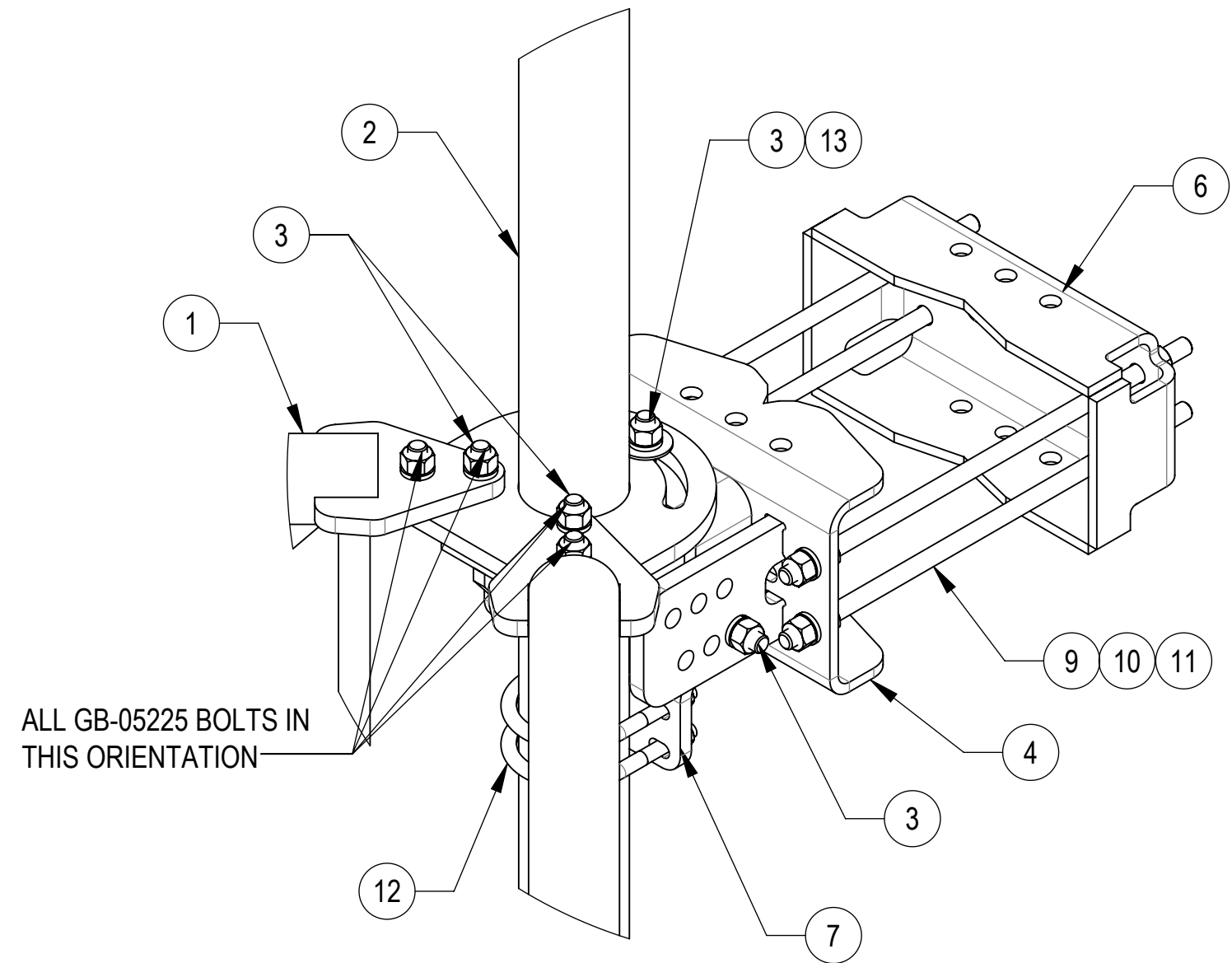

DETAIL A
SCALE 1 : 5

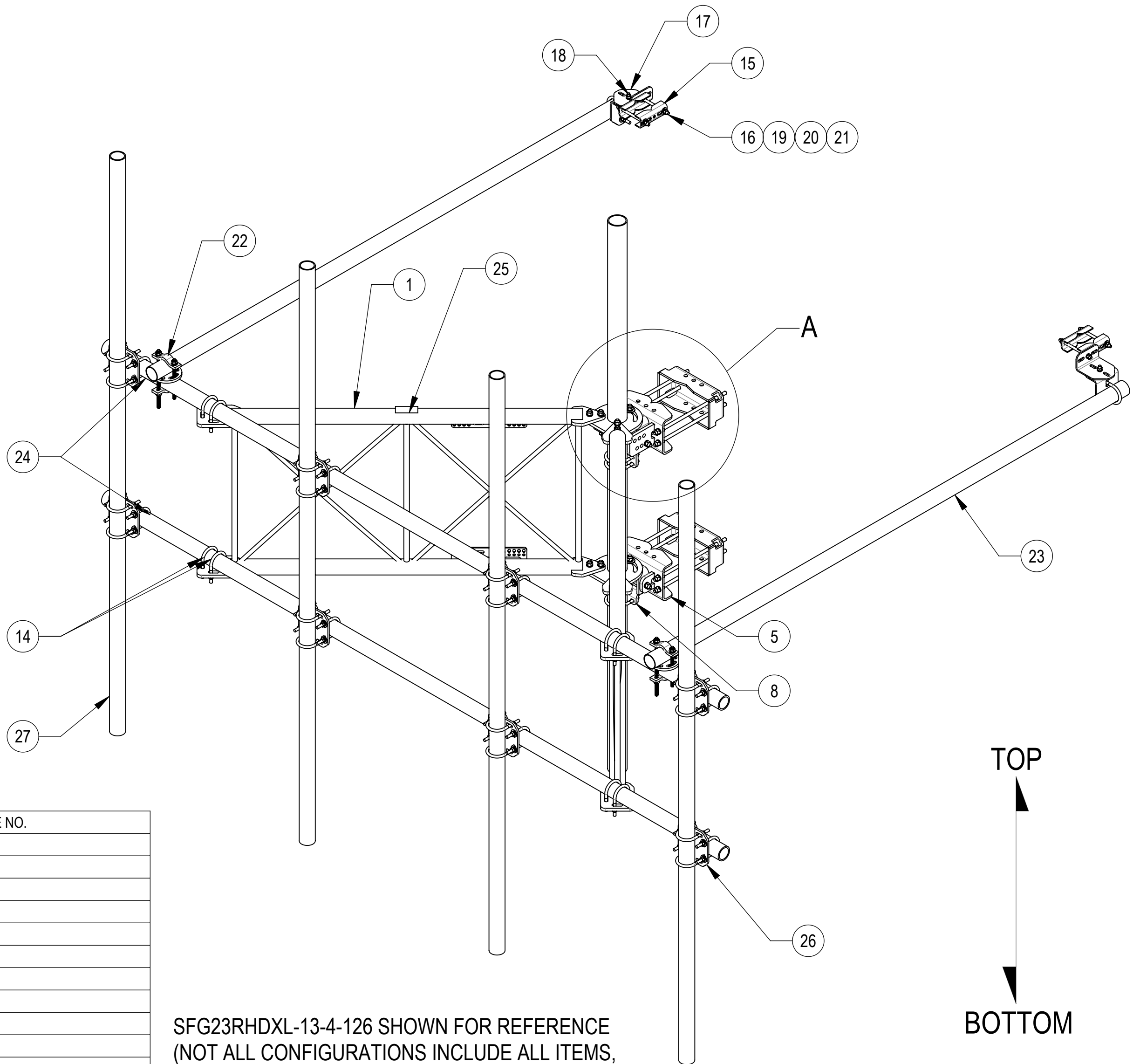

SFG23RHDXL-13-4-126 SHOWN FOR REFERENCE
(NOT ALL CONFIGURATIONS INCLUDE ALL ITEMS,
SEE NOTES IN TABLE)

ALLOWABLE TIEBACK ANGLE
± 15 DEGREES VERTICAL
± 25 DEGREES HORIZONTAL

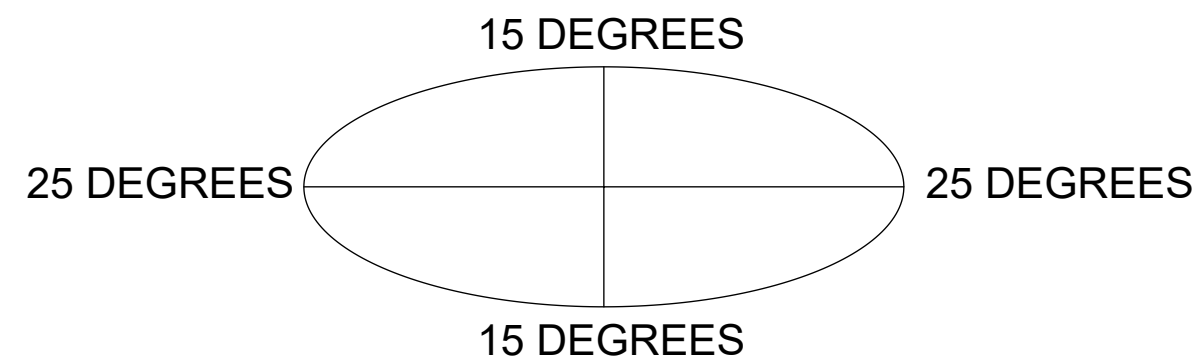

COMPONENT PART NUMBERS PROVIDED FOR ASSEMBLY PURPOSES;
INDIVIDUAL COMPONENTS MAY BE SHIPPED AS PARTS WITHIN AN INCLUDED KIT.

ITEM	PART NO.	DESCRIPTION	QTY.	WEIGHT	NOTE NO.
1	SFG23180-00	ARM, STANDOFF, SFG23	2	123.43 LBS	
2	SFG2204	WELDMENT, BACK VERTICAL ARM MOUNT	1	97.29 LBS	
3	GB-05225	5/8" X 2-1/4" GALV BOLT KIT	14	0.28 LBS	
4	SFG2380	WELDMENT, HD, TOP TAPER BRACKET	1	22.78 LBS	
5	SFG2381	WELDMENT, HD, LOWER TOWER LEG BRACKET	1	17.42 LBS	
6	SFG2289	G2 RRU BACK CLAMP, HD	2	18.65 LBS	
7	SFG2386	WELDMENT, SFG2 AZIMUTH BRACKET	1	10.07 LBS	
8	SFG2397-00	WELDMENT, G23 AZIMUTH BRACKET	1	7.94 LBS	
9	MT-382-18	5/8" X 18" THREADED ROD	8	1.43 LBS	
10	GWL-05	5/8" GALV LOCK WASHER	16	0.03 LBS	
11	GN-05	5/8" GALV HEX NUT	24	0.08 LBS	
12	GUB-4355	1/2" X 3-5/8" X 5" GALV U-BOLT	3	0.71 LBS	
13	GWF-05	5/8" GALV FLAT WASHER, 1.7OD	2	0.06 LBS	
14	GUB-4352	1/2" X 3" X 5-1/4" GALV U-BOLT	10	0.71 LBS	
15	SAB01	FORMED CLAMP	4	1.35 LBS	
16	MT-379-8	1/2" X 8" GALV THREADED ROD	4	0.45 LBS	
17	XAU01	ANGLE, CROSSOVER, 1.9-3.5" X 1.9-3.5" OD	4	2.98 LBS	
18	GB-04145	1/2" X 1-1/2" GALV BOLT KIT	2	0.13 LBS	
19	GWF-04	1/2" GALV FLAT WASHER	8	0.04 LBS	
20	GWL-04	1/2" GALV LOCK WASHER	10	0.01 LBS	
21	GN-04	1/2" GALV HEX NUT	10	0.04 LBS	
22	XP-R	CROSSOVER PLATE, ROUND, UP TO 3.5" OD	2	6.20 LBS	
23	MT546120120	PIPE, 2.875"OD X 120"	2	35.44 LBS	
24	MT546156276	PIPE, 2.875"OD X 156"	2	99.95 LBS	PART NO. SEE INDIVIDUAL DRAWING
25	SFG23100	LABEL, SFG23RHDXL	1	0.04 LBS	
26	XP-2525	CROSSOVER PLATE KIT, 2-7/8 OD X 2-7/8 OD	8	8.37 LBS	QTY SEE INDIVIDUAL DRAWING
27	MT-546-126	PIPE, 2.875"OD X 126"	4	61.05 LBS	PART NO. AND QTY SEE INDIVIDUAL DRAWING

COMMSCOPE, INC. OF NORTH CAROLINA				
TITLE SFG23RHDXL SECTOR FRAME SERIES				
SIZE C	SCALE 1:16	DOCUMENT NO. SFG23RHDXL		
DRAWING		VERSION	STATUS	REVISION
		03	RE	D
				SHEET 3 OF 12

4

3

2

1

TIEBACK MUST BE CONNECTED TO A RIGID MEMBER THAT PROVIDES ADEQUATE SUPPORT WITHIN THE LIMITS NOTED IN THE TIEBACK ANGLE RANGE DETAIL. UNLESS APPROVED BY ENGINEER OF RECORD. SPINE STEM OF NEIGHBORING MOUNT IS ACCEPTABLE.

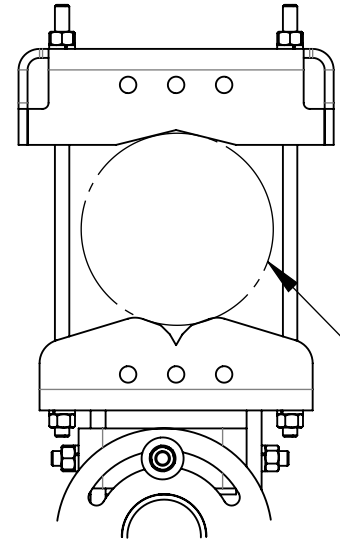
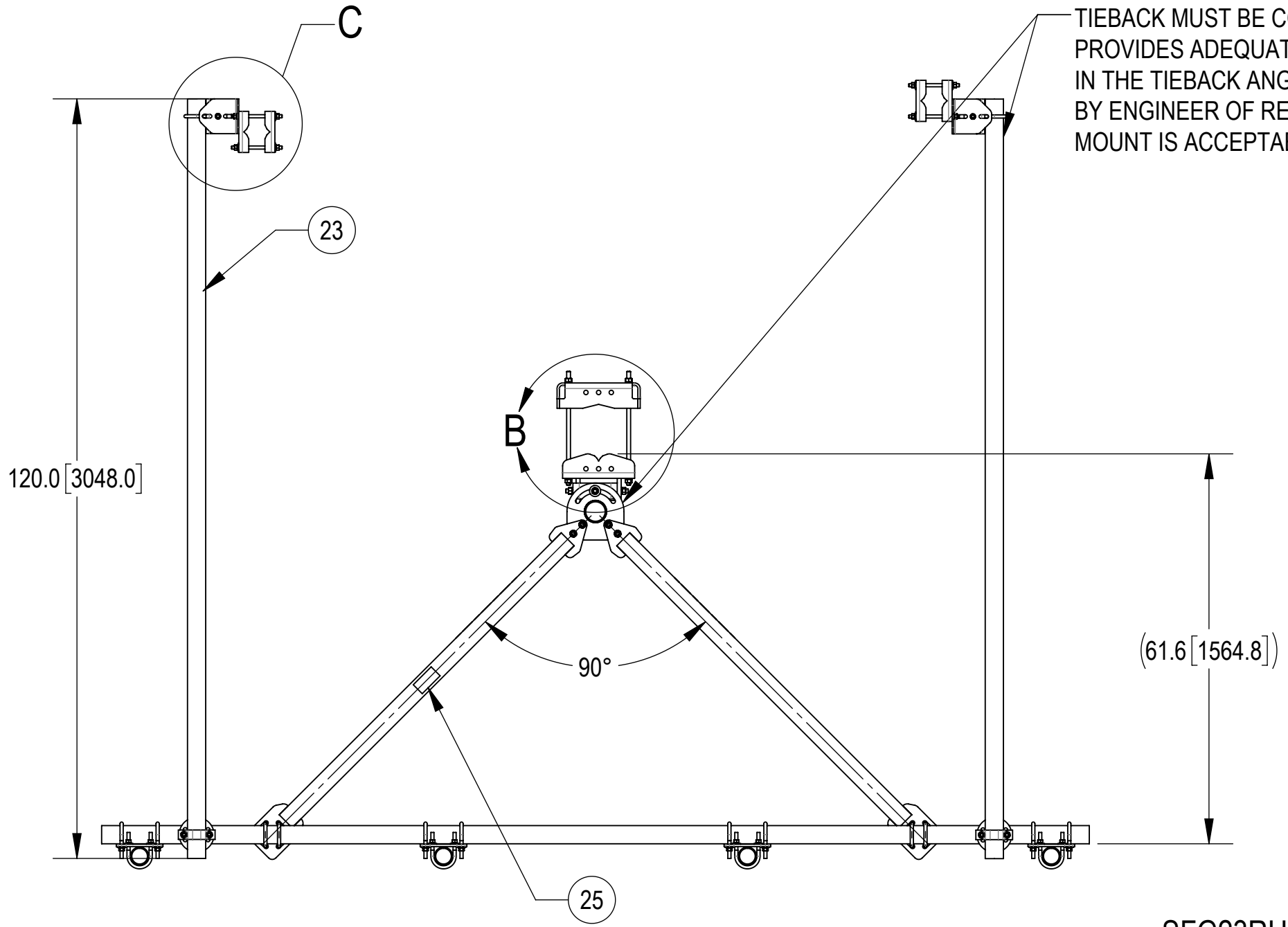

DETAIL B
SCALE 1 : 8

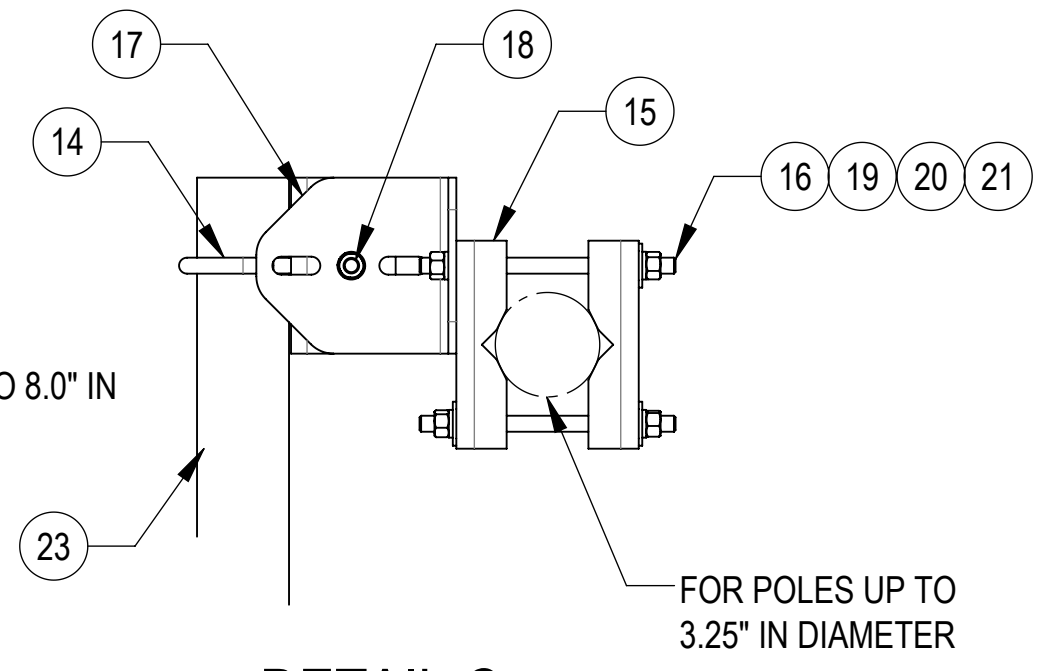

DETAIL C
SCALE 1 : 6

ALLOWABLE TIEBACK ANGLE
± 15 DEGREES VERTICAL
± 25 DEGREES HORIZONTAL

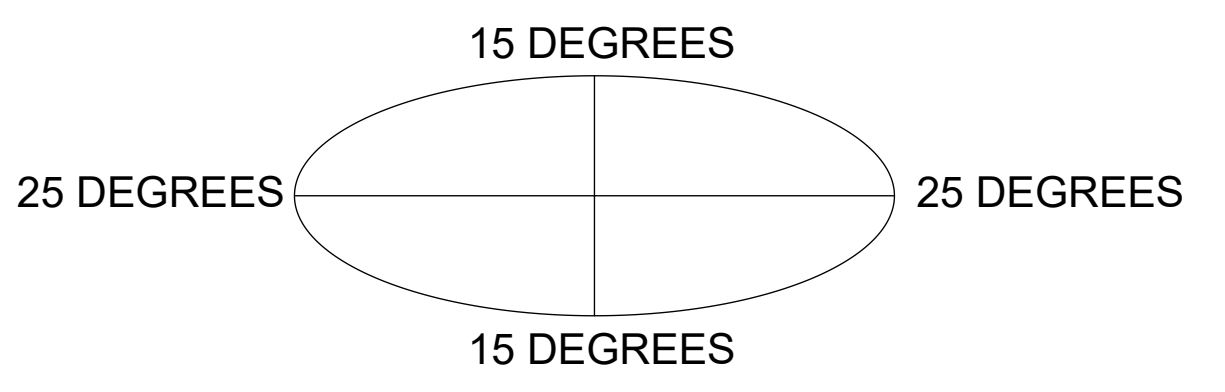

SFG23RHDXL-13-4-126 SHOWN FOR REFERENCE
(NOT ALL CONFIGURATIONS INCLUDE ALL ITEMS,
SEE NOTES IN TABLE ON SHEET 3)

C

C

B

B

A

A

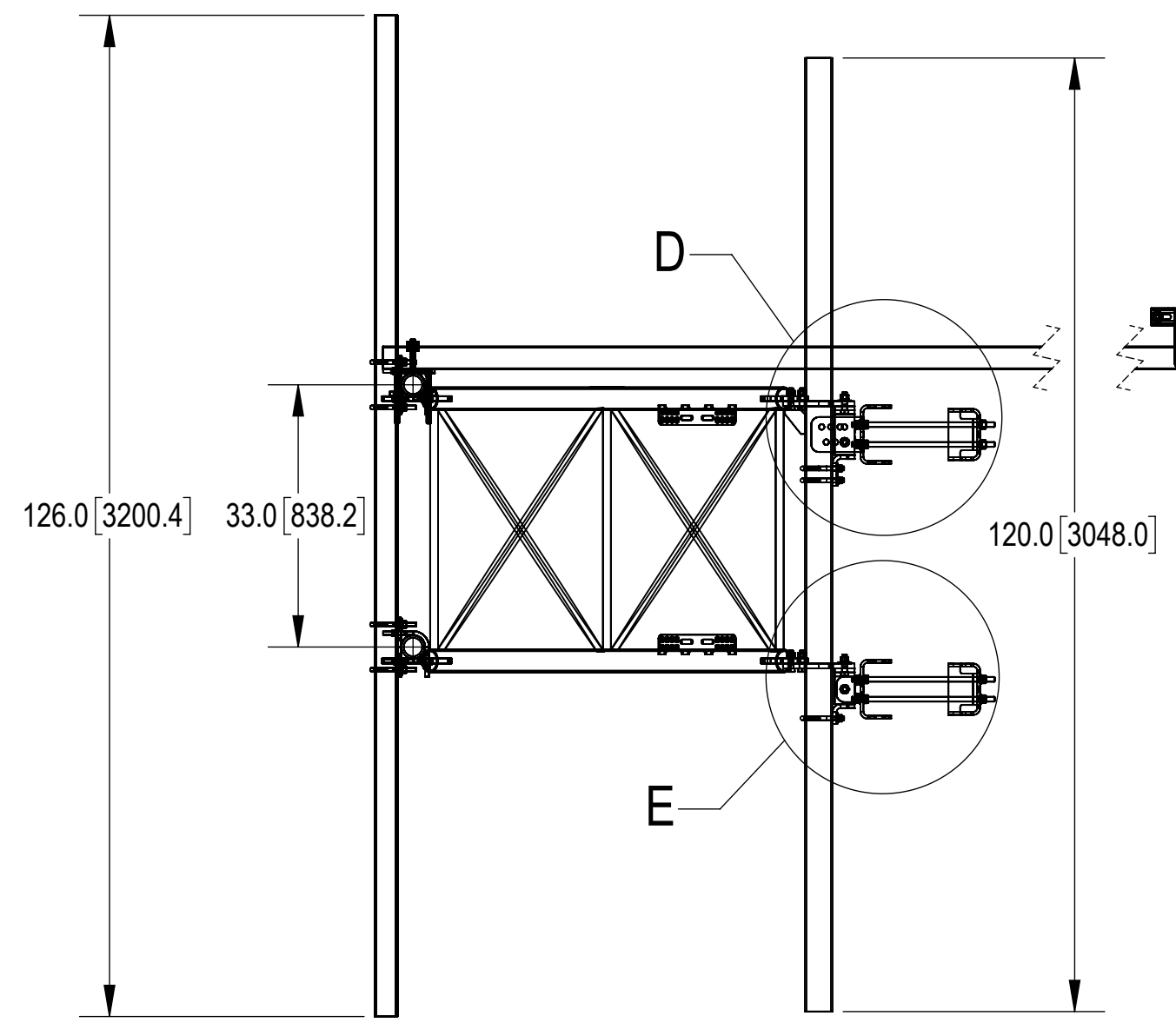
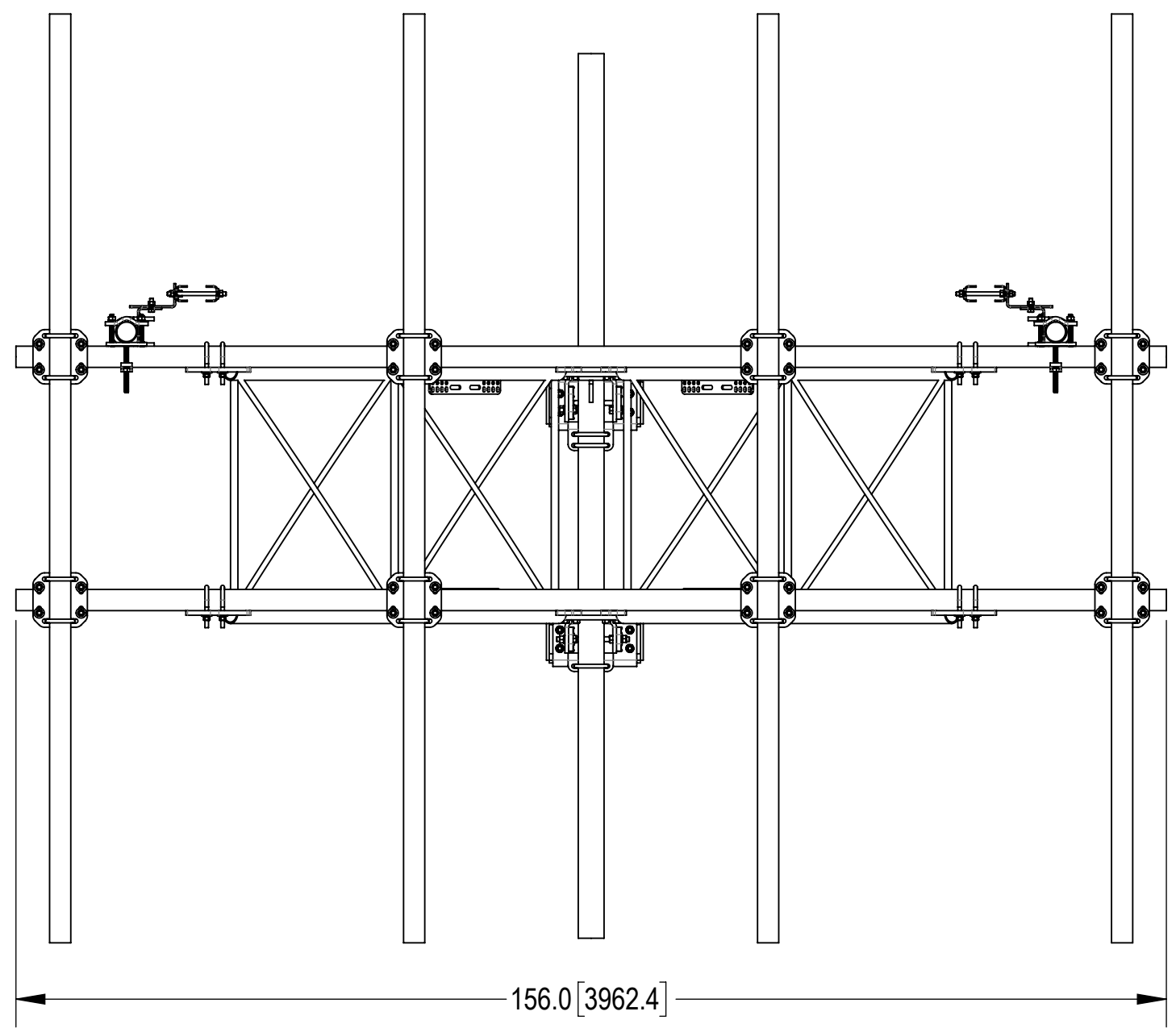

TOP
↓
BOTTOM

COMMSCOPE, INC. OF NORTH CAROLINA				
TITLE SFG23RHDXL SECTOR FRAME SERIES				
SIZE C	SCALE 1:21	DOCUMENT NO. SFG23RHDXL		
DRAWING		VERSION	STATUS	REVISION
		03	RE	D
				SHEET 4 OF 12

4

3

2

1

4

3

2

1

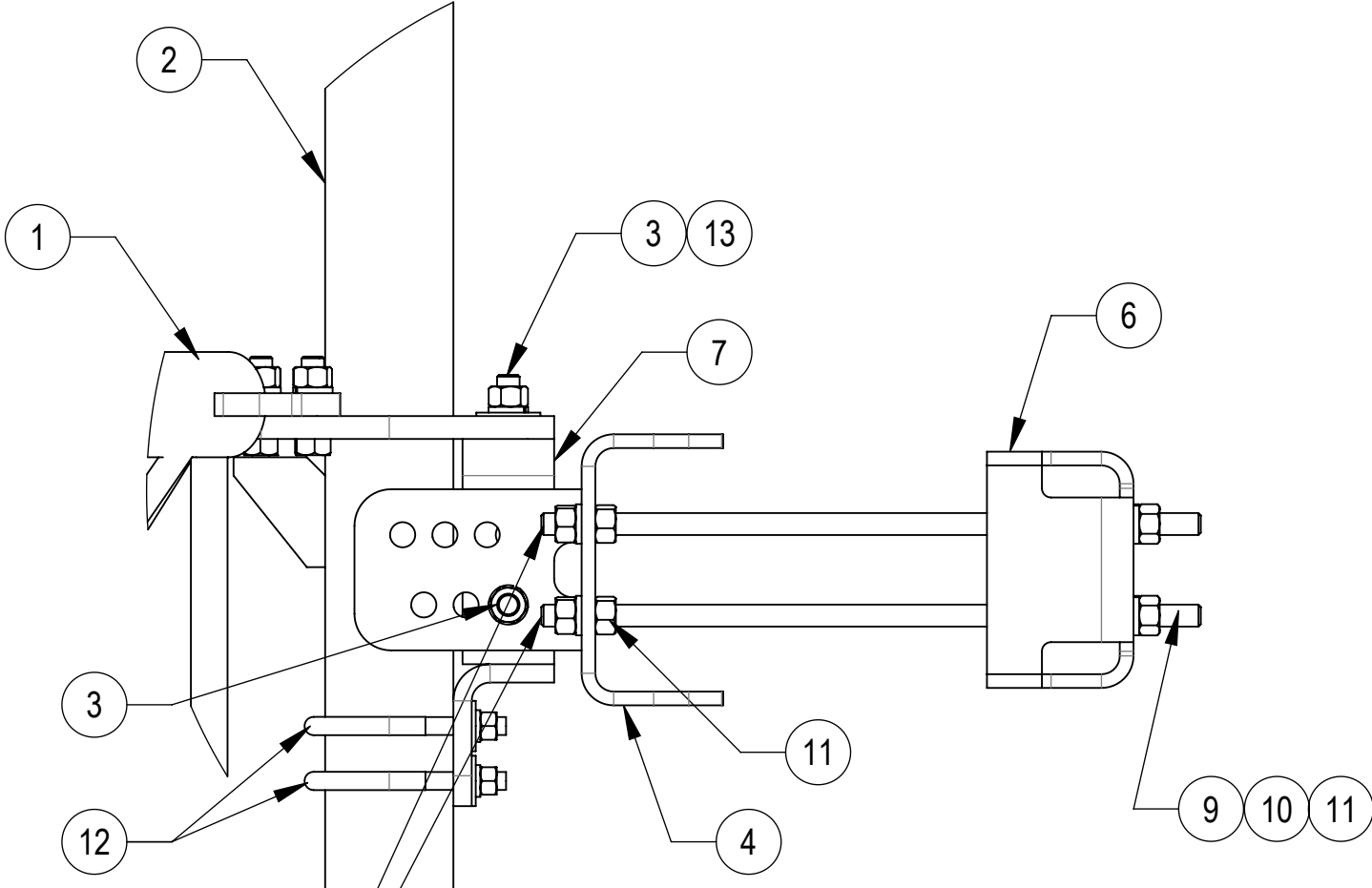

DETAIL D
SCALE 1 : 5

THE THREADED ROD CAN ONLY EXPOSE 4 TO 7 THREADS ON ONE SIDE OF THE BRACKET, WHICH IS TO PREVENT INTERFERENCE WITH THE SIDE BOLTS

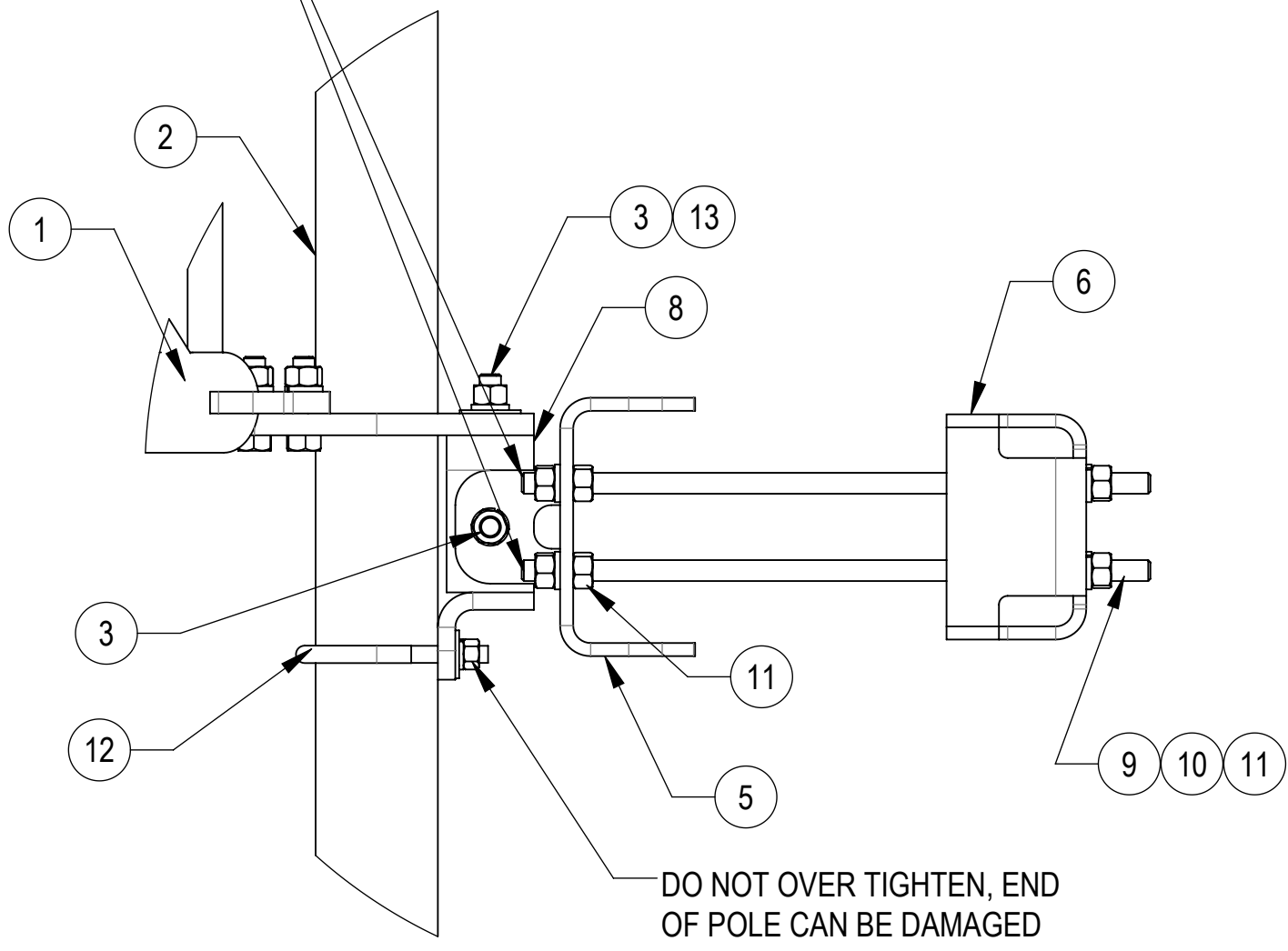

DETAIL E
SCALE 1 : 5

DO NOT OVER TIGHTEN, END OF POLE CAN BE DAMAGED

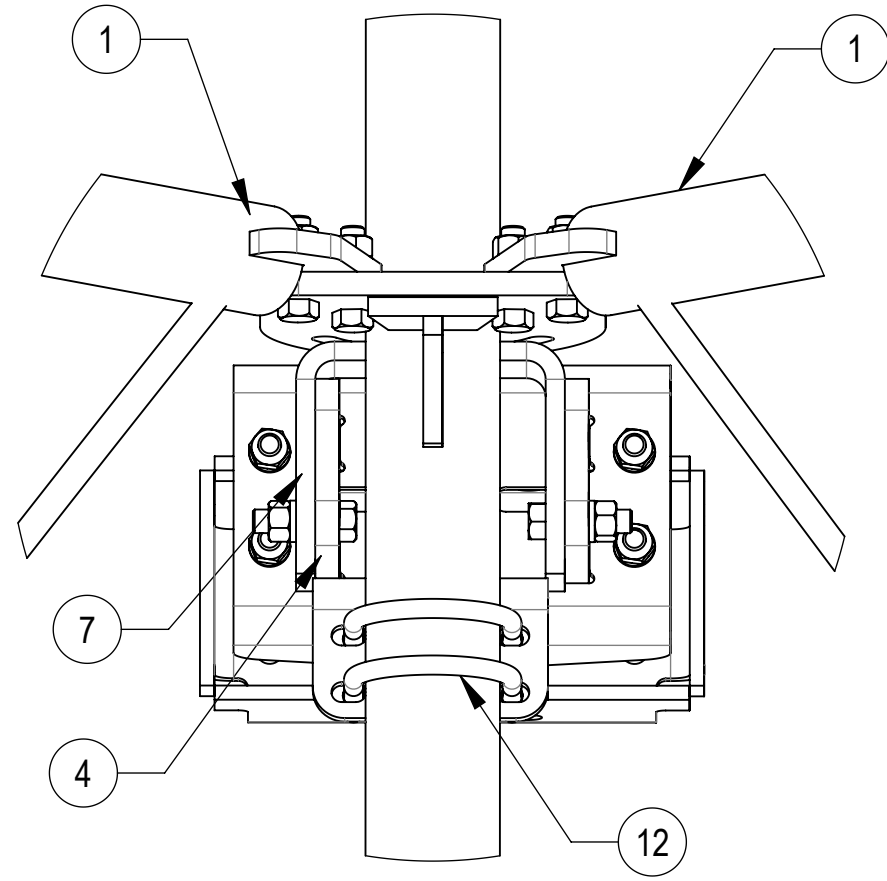

DETAIL ISO TOP ROTATED VIEW
SCALE 1 : 5

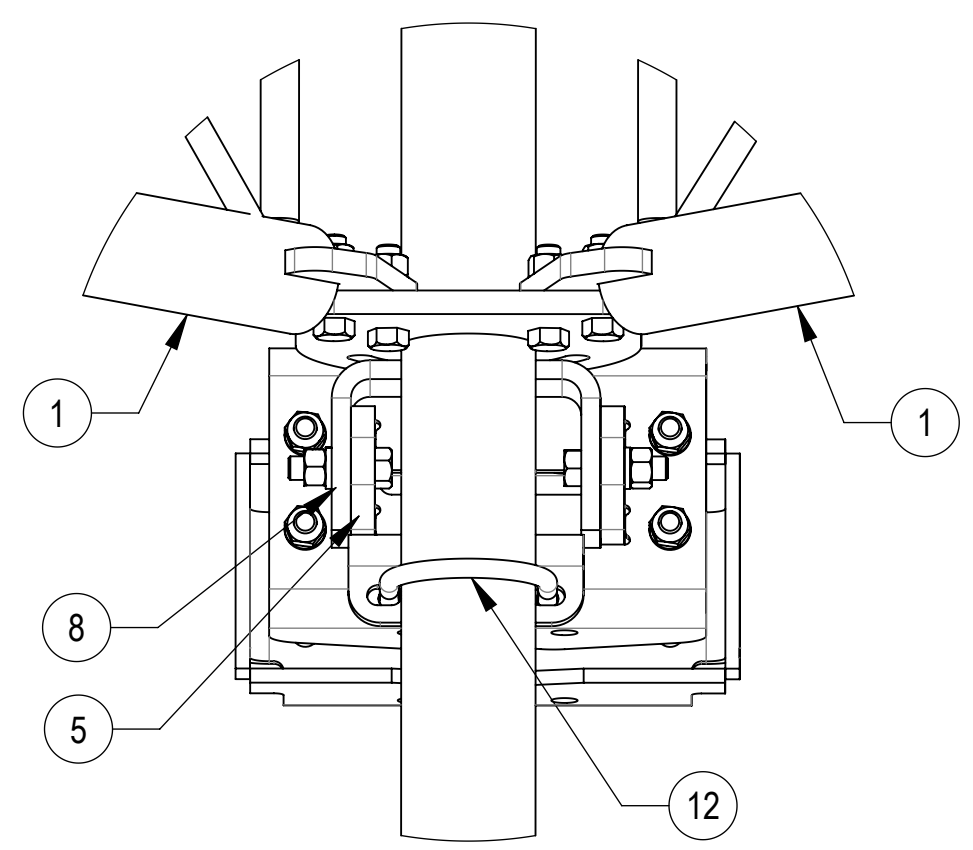

DETAIL ISO BOTTOM ROTATED VIEW
SCALE 1 : 5

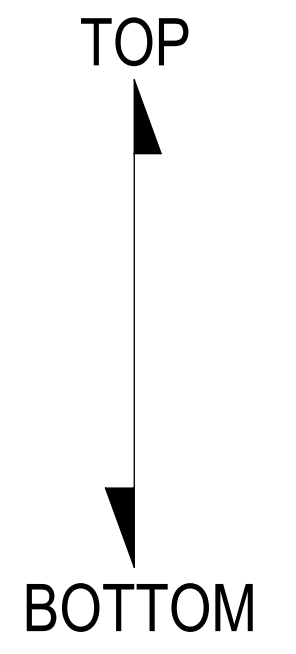

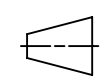
COMMSCOPE, INC. OF NORTH CAROLINA				
TITLE SFG23RHDXL SECTOR FRAME SERIES				
SIZE C	SCALE 1:21	DOCUMENT NO. SFG23RHDXL		
 		DRAWING		SHEET 5 OF 12
		VERSION 03	STATUS RE	

4

3

2

1

D

D

C

C

B

B

A

A

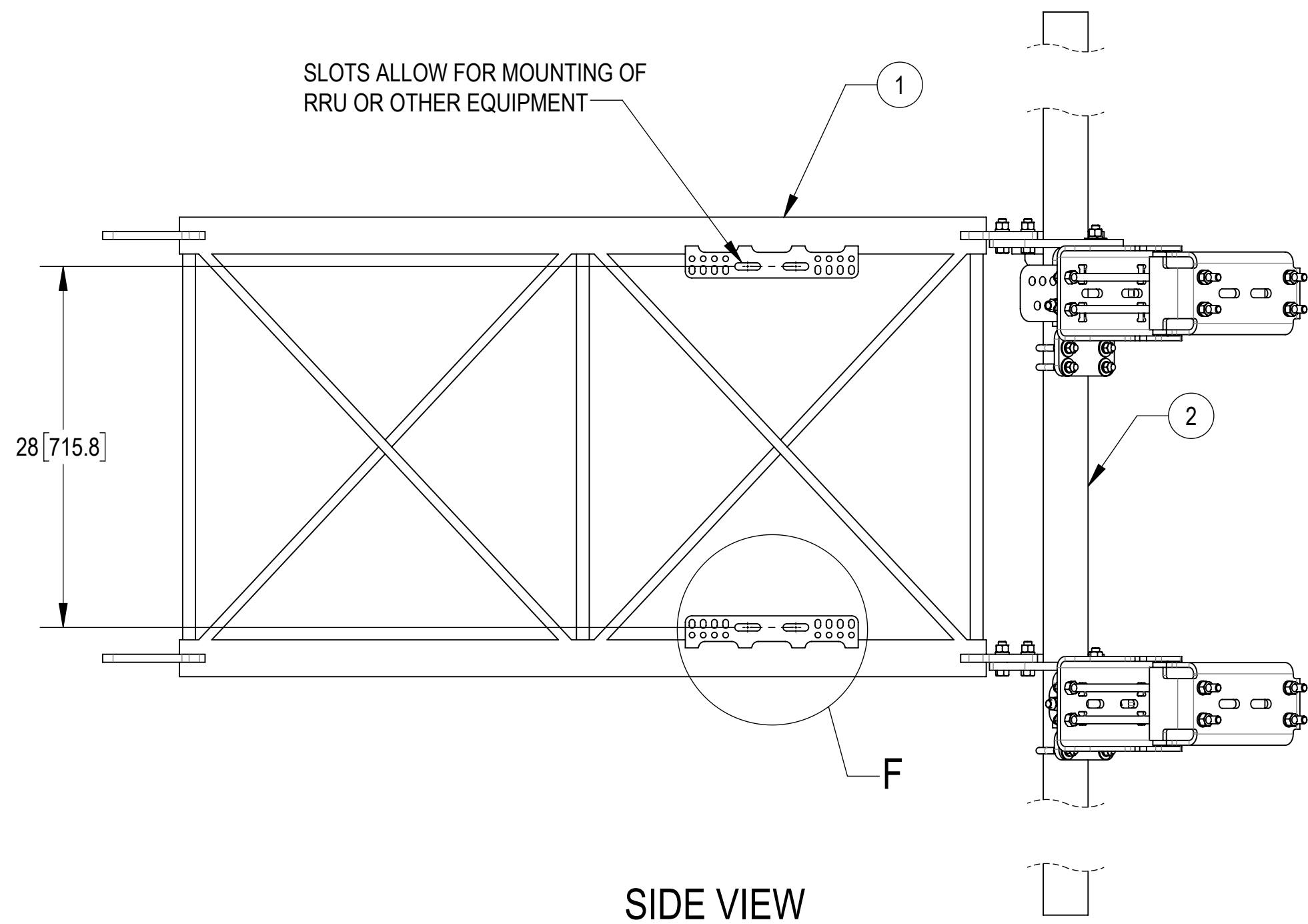

SIDE VIEW

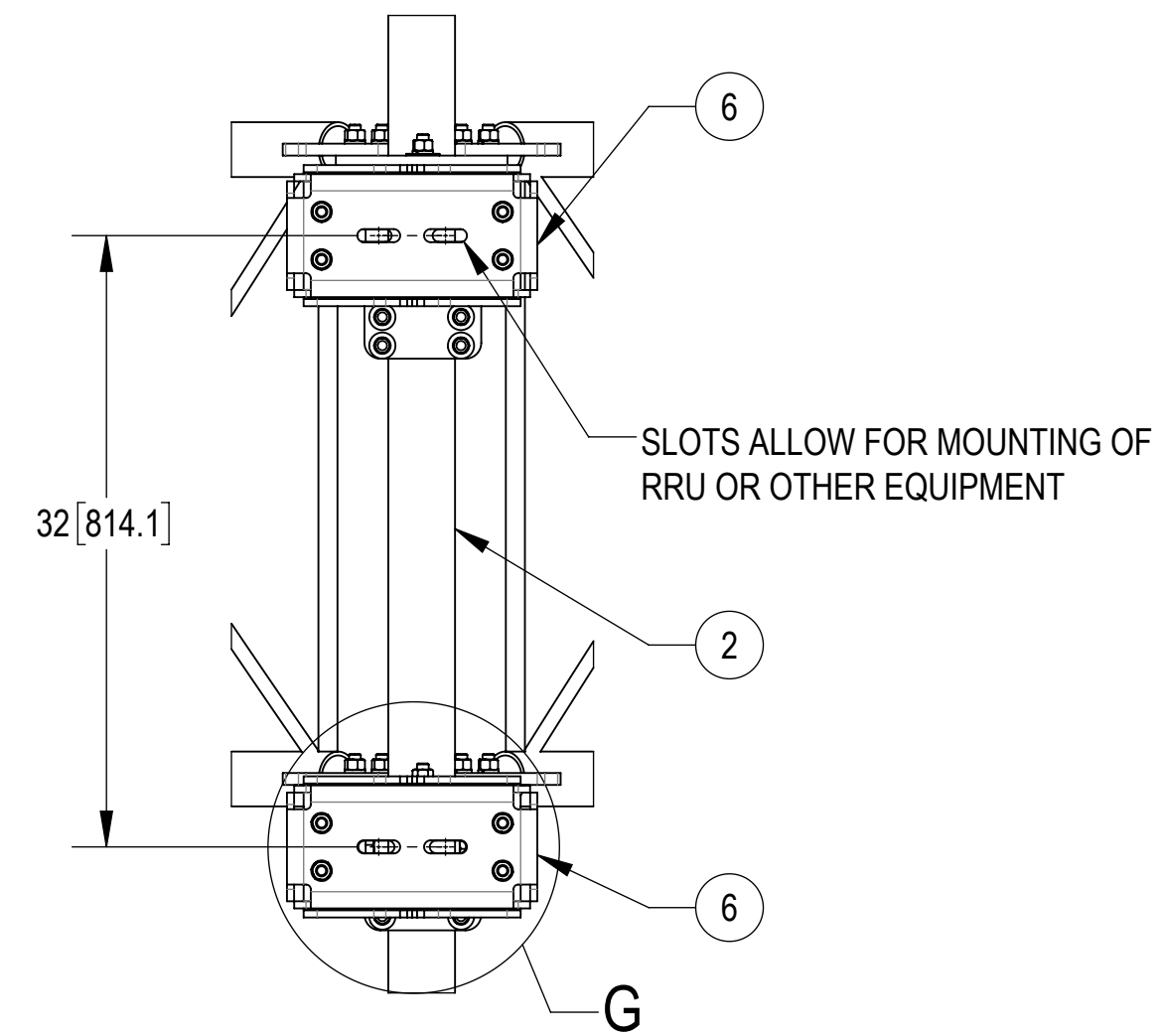

BACK CROP VIEW

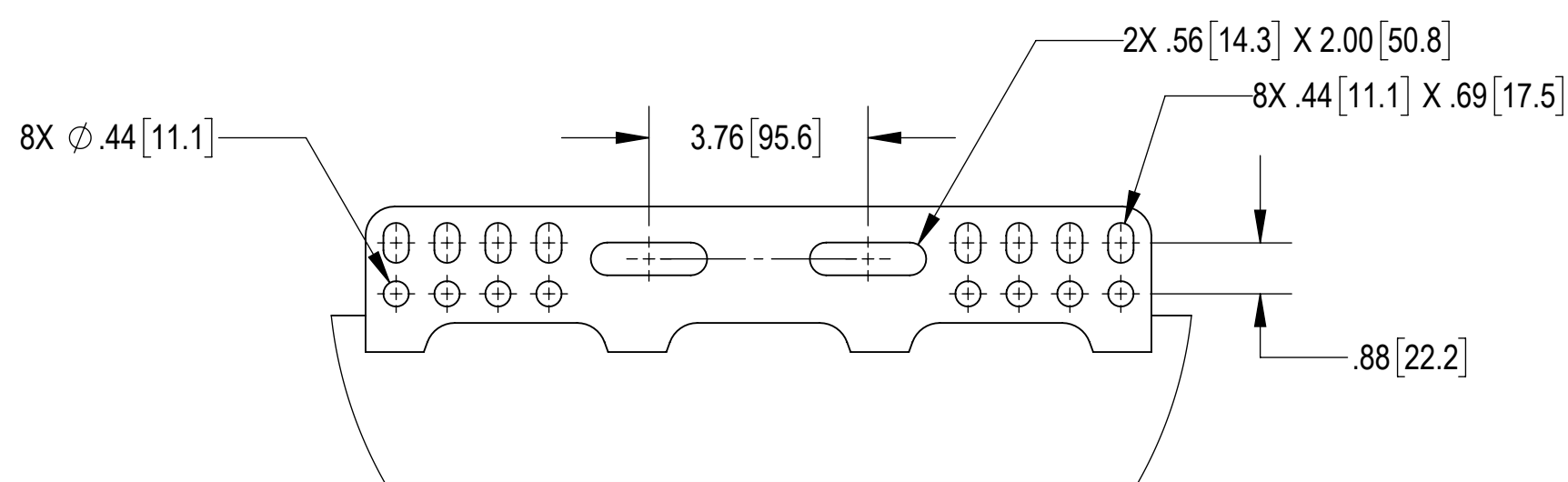

DETAIL F
SCALE 1 : 3

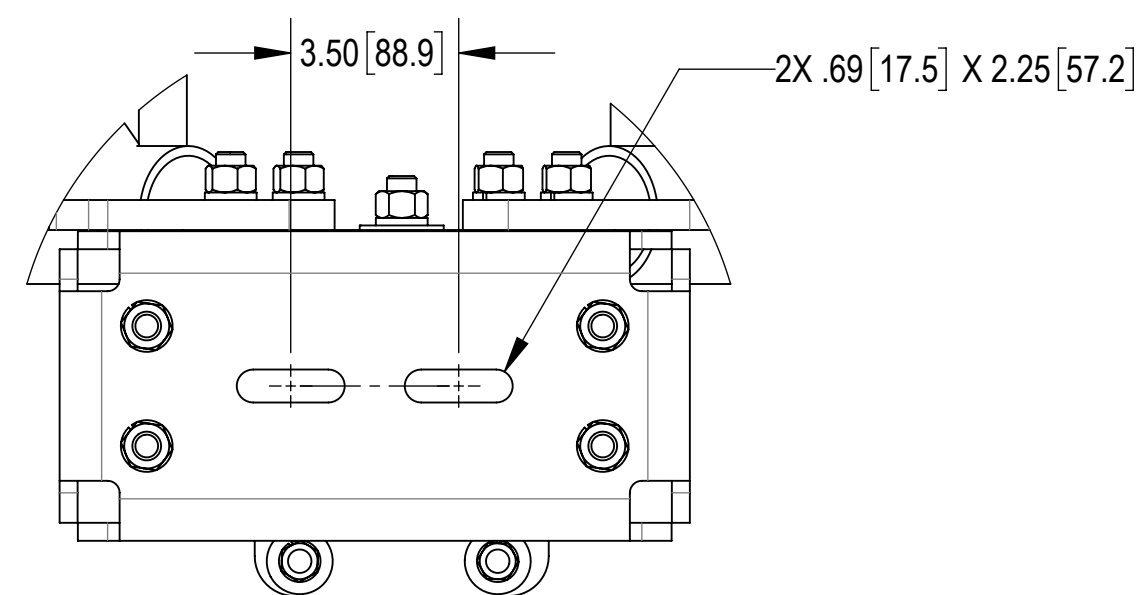

DETAIL G
SCALE 1 : 4

COMMSCOPE, INC. OF NORTH CAROLINA				
TITLE SFG23RHDXL SECTOR FRAME SERIES				
SIZE C	SCALE 1:10	DOCUMENT NO. SFG23RHDXL		
		DRAWING		SHEET 6 OF 12
		VERSION 03	STATUS RE	

4

3

2

1

INSTALLATION SEQUENCE - REFERENCE ONLY

STEP 1: ATTACH STANDOFF ARMS (SFG23180-00) TO BACK VERTICAL ARM MOUNT (SFG2204) USING BOLT KITS (GB-05225)
ATTACH LABEL (SFG23100) ON TOP OF STANDOFF ARMS(SFG23180-00) . (WIPE GALVANIZED SURFACE WITH ALCOHOL CLEANER BEFORE APPLYING LABEL.)

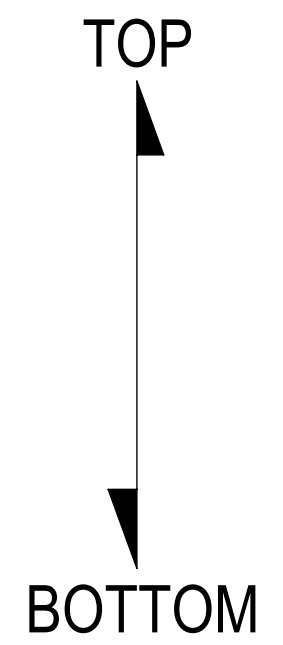
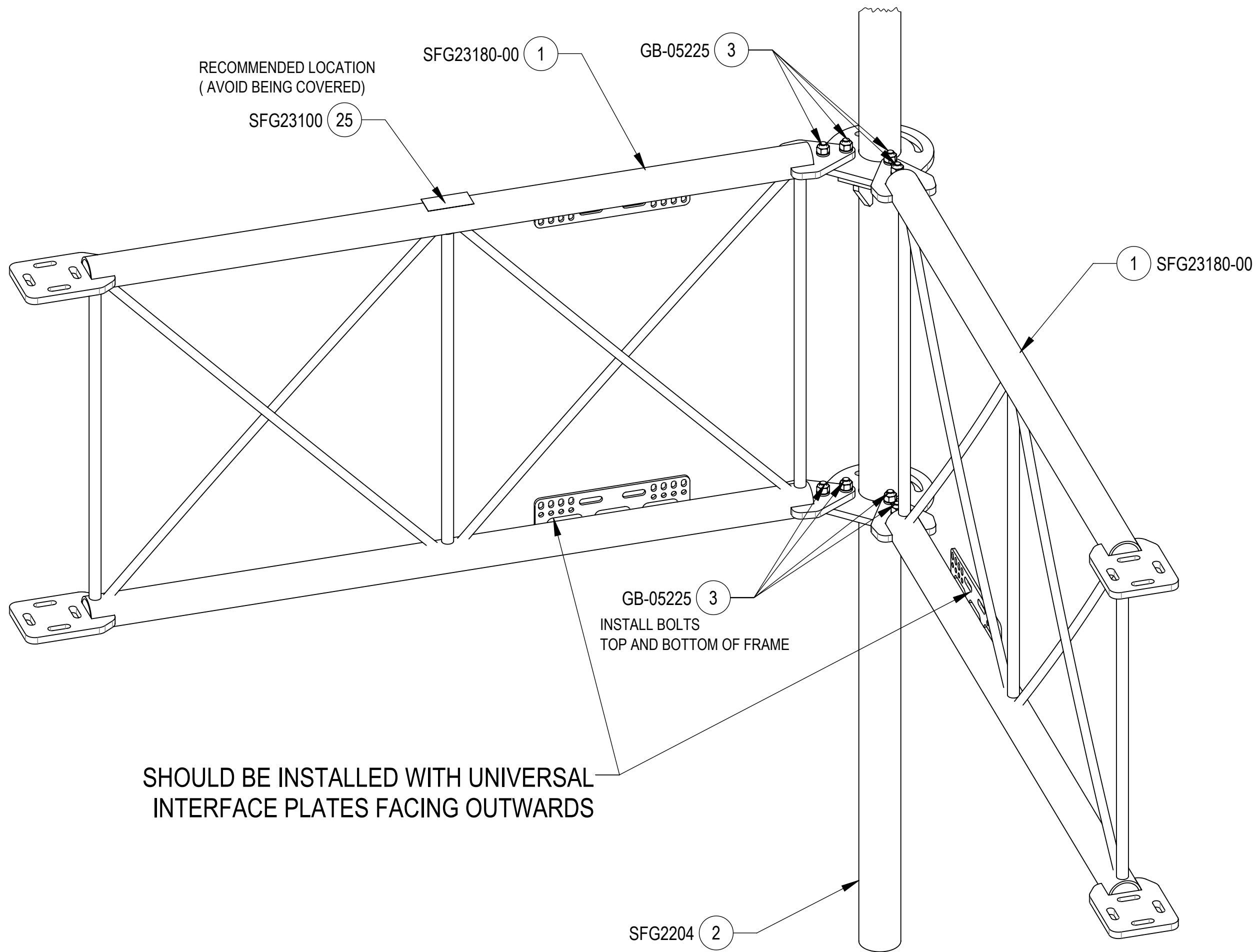

COMMSCOPE, INC. OF NORTH CAROLINA				
TITLE SFG23RHDXL SECTOR FRAME SERIES				
SIZE C	SCALE 1:32	DOCUMENT NO. SFG23RHDXL		
		DRAWING		SHEET
		VERSION 03	STATUS RE	REVISION D
				7 OF 12

4

3

2

1

4

3

2

1

STEP 2: AT TOP, ATTACH AZIMUTH/TAPER BRACKET (SFG2386) TO BACK VERTICAL ARM MOUNT (SFG2204) USING BOLT KIT (GB-05225),
 FLAT WASHER (GWF-05) AND U-BOLT KITS (GUB-4355);
 AT BOTTOM, ATTACH AZIMUTH/TAPER BRACKET (SFG2387-00) TO BACK VERTICAL ARM MOUNT (SFG2204) USING BOLT KIT (GB-05225),
 FLAT WASHER (GWF-05) AND U-BOLT KIT (GUB-4355);

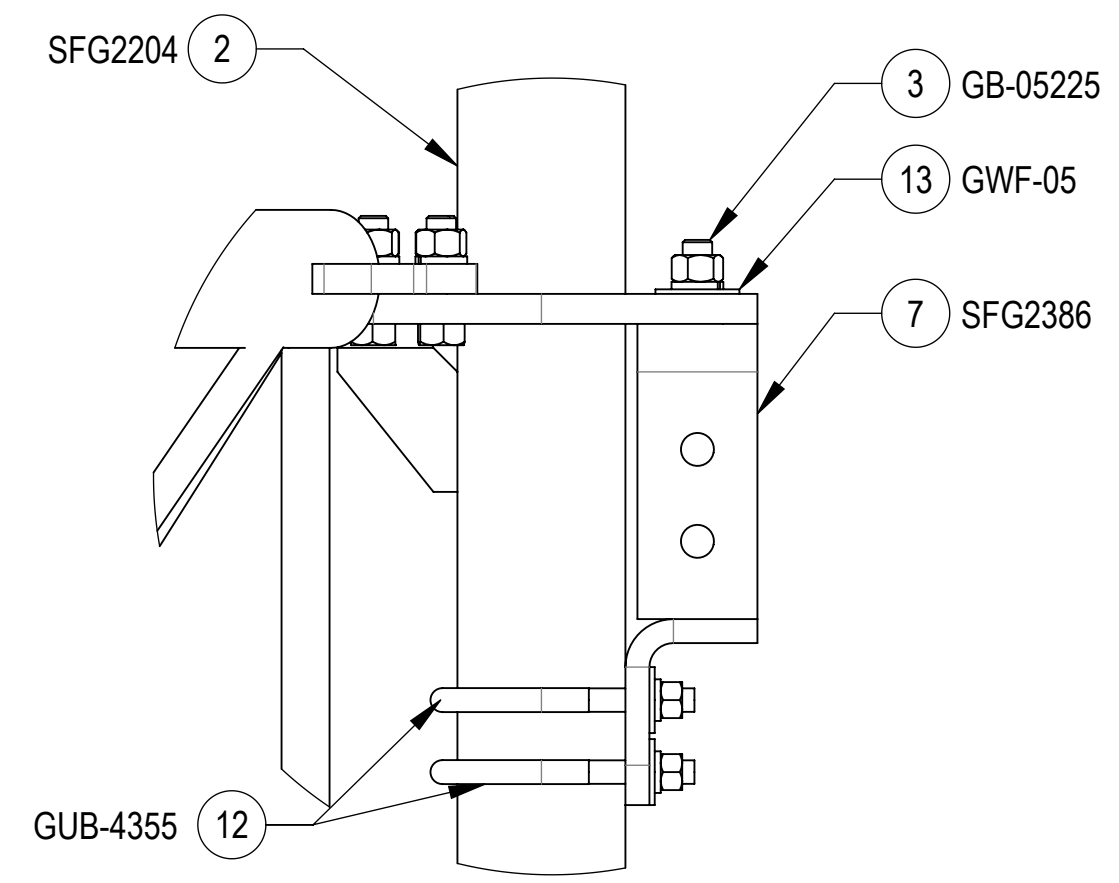
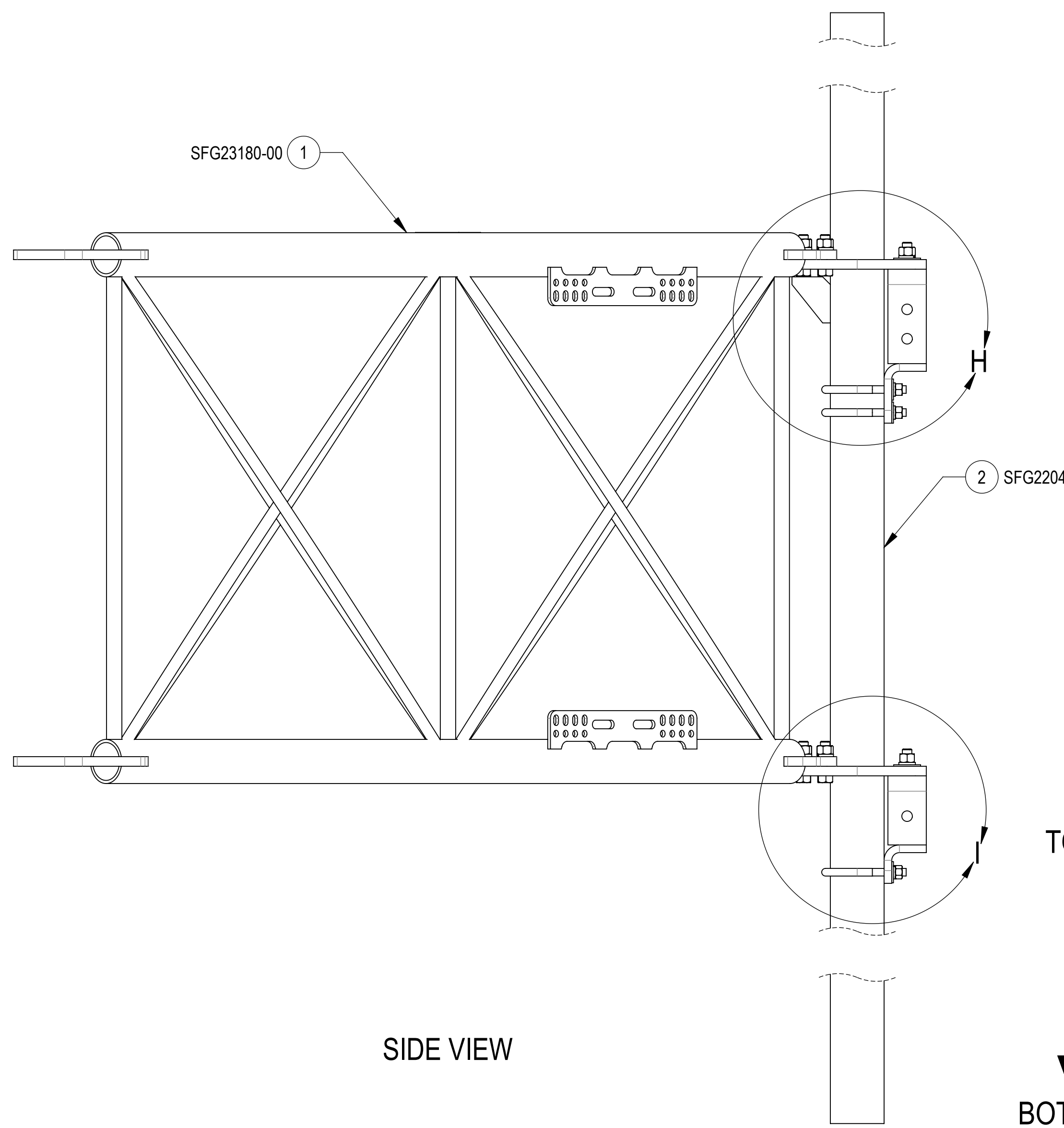

DETAIL H
 SCALE 1 : 4

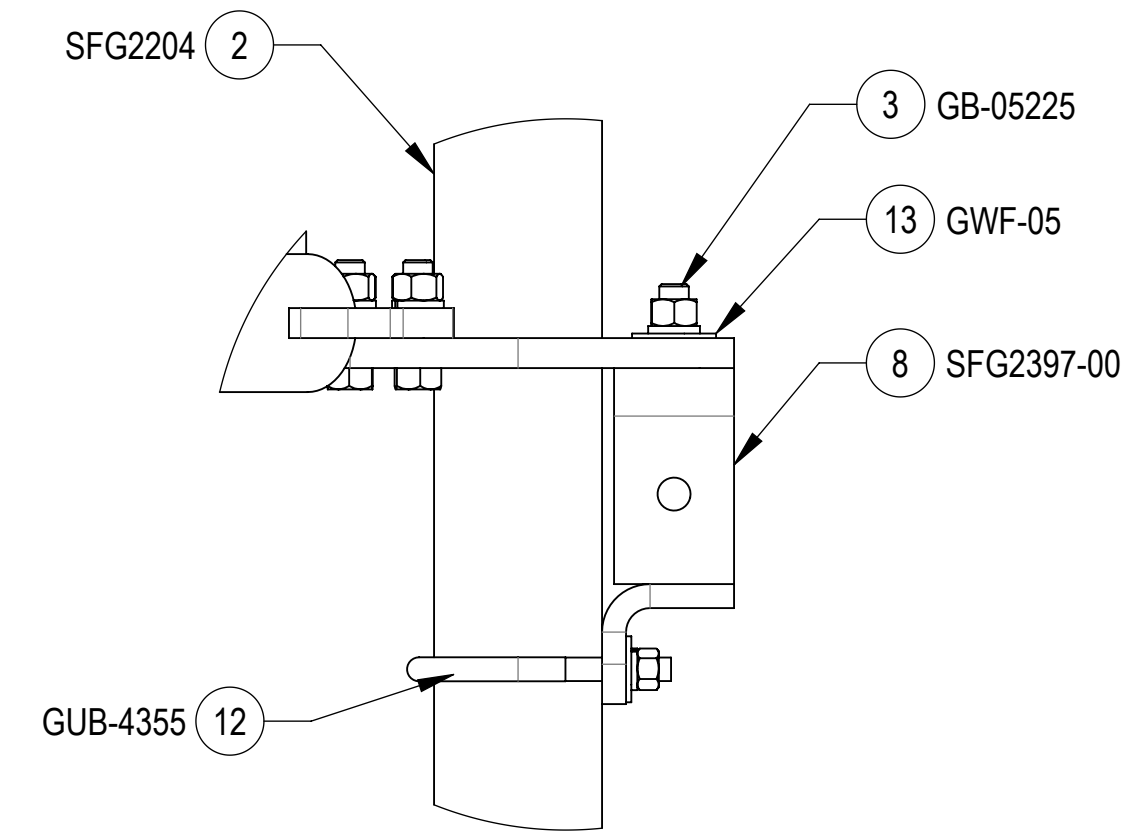

DETAIL I
 SCALE 1 : 4

SIDE VIEW

TOP
 ↓
 BOTTOM

COMMSCOPE, INC. OF NORTH CAROLINA				
TITLE SFG23RHDXL SECTOR FRAME SERIES				
SIZE C	SCALE 1:24	DOCUMENT NO. SFG23RHDXL		
		DRAWING		SHEET 8 OF 12
		VERSION 03	STATUS RE	

4

3

2

1

STEP 3: AT TOP, ATTACH TOP TAPER BRACKET (SFG2380) AZIMUTH/TAPER BRACKET (SFG2386) USING BOLTS KITS (GB-05225)
 AT BOTTOM, ATTACH LOWER TOWER LEG BRACKET (SFG2381) TO AZIMUTH/TAPER BRACKET (SFG2397-00) USING BOLTS KITS (GB-05225)

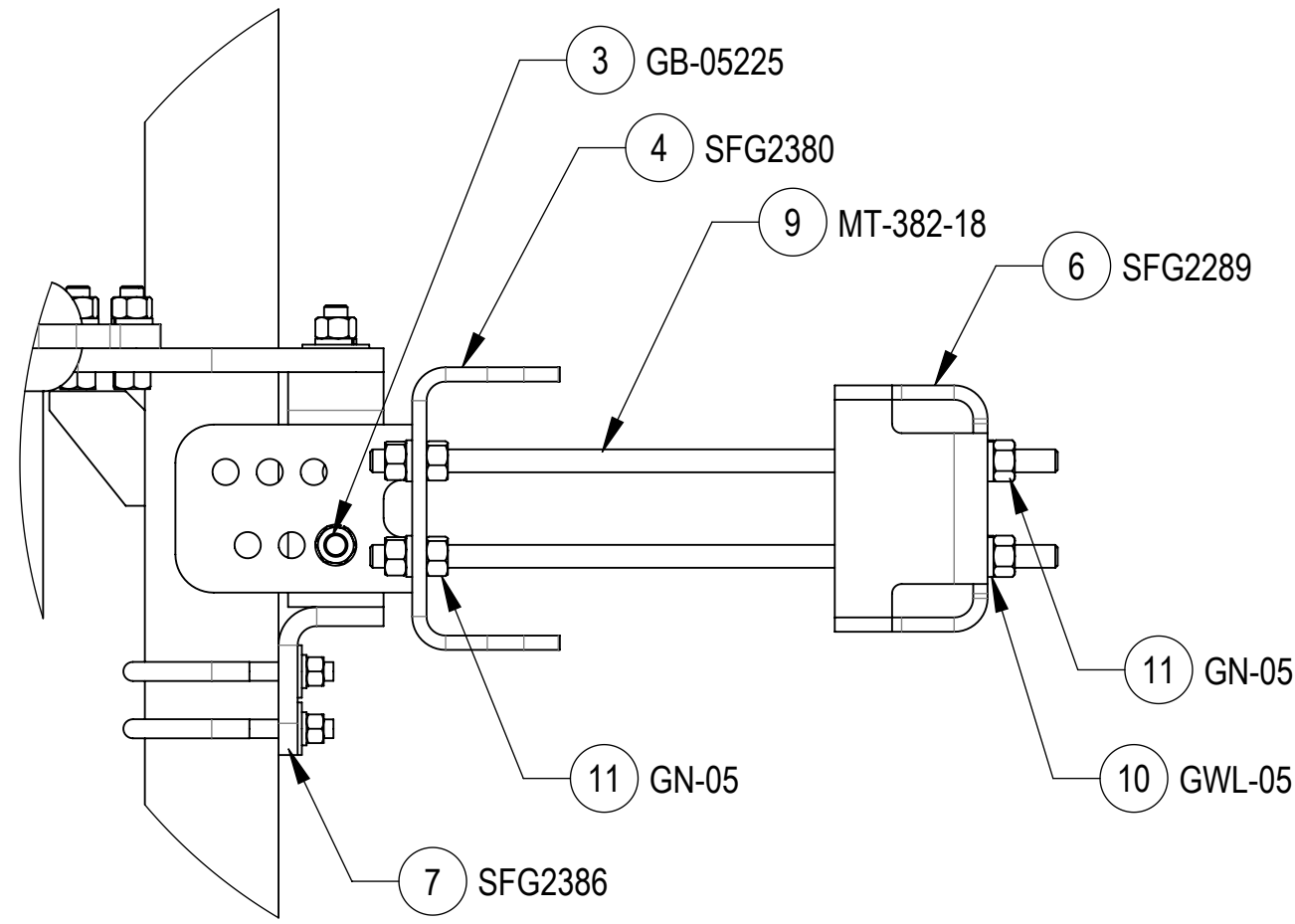

DETAIL J
SCALE 1 : 5

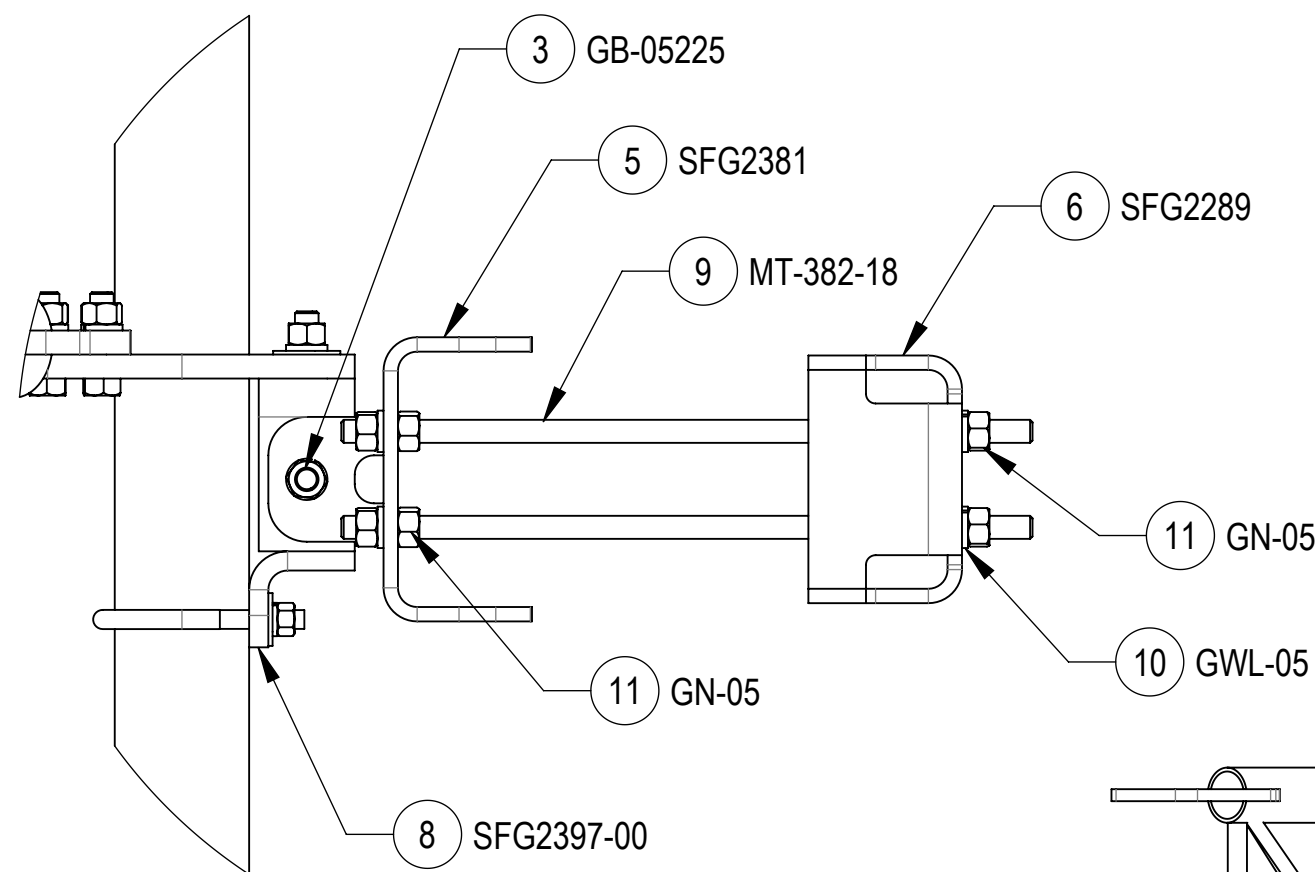

DETAIL K
SCALE 1 : 5

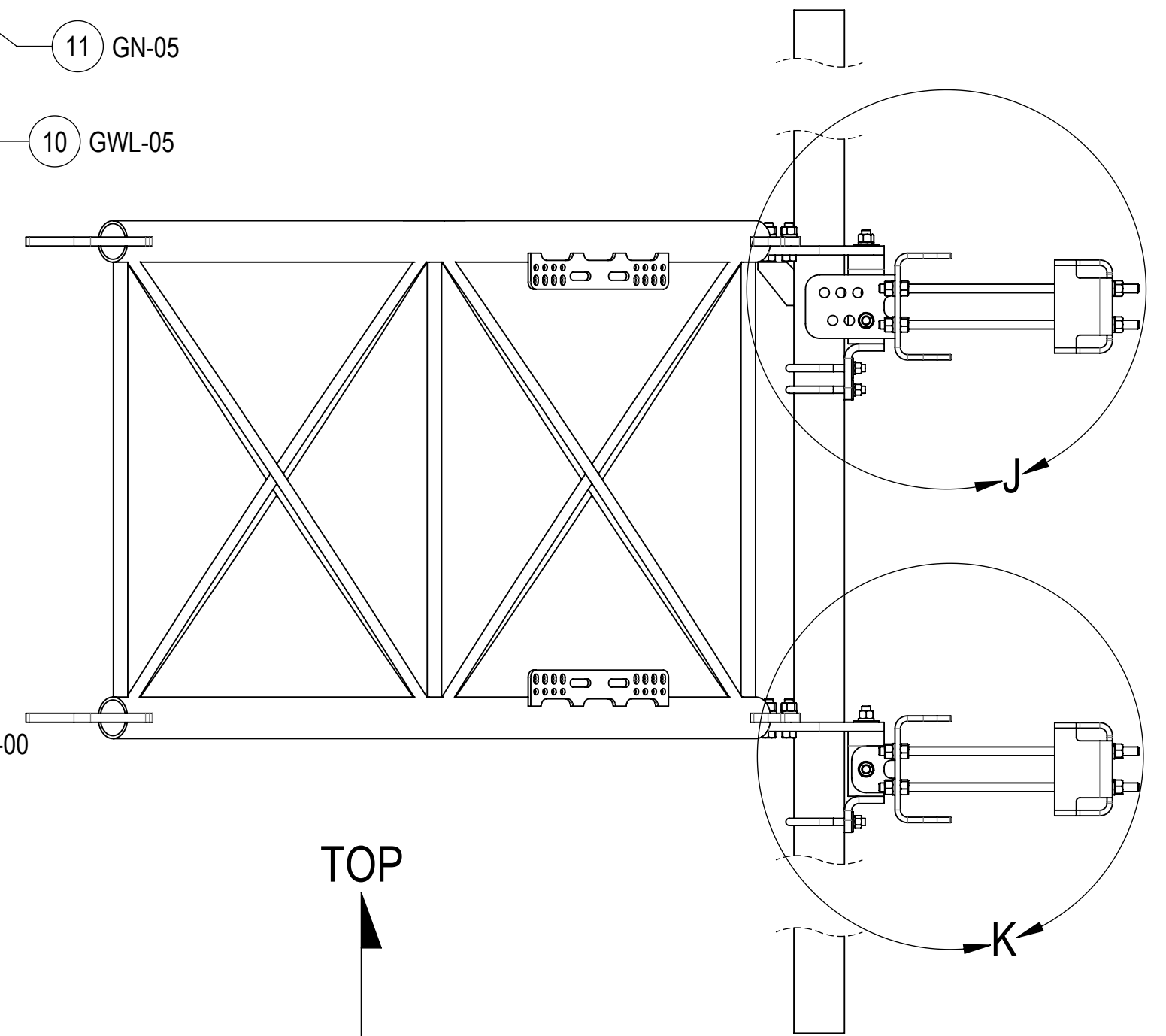

TOP
↓
BOTTOM

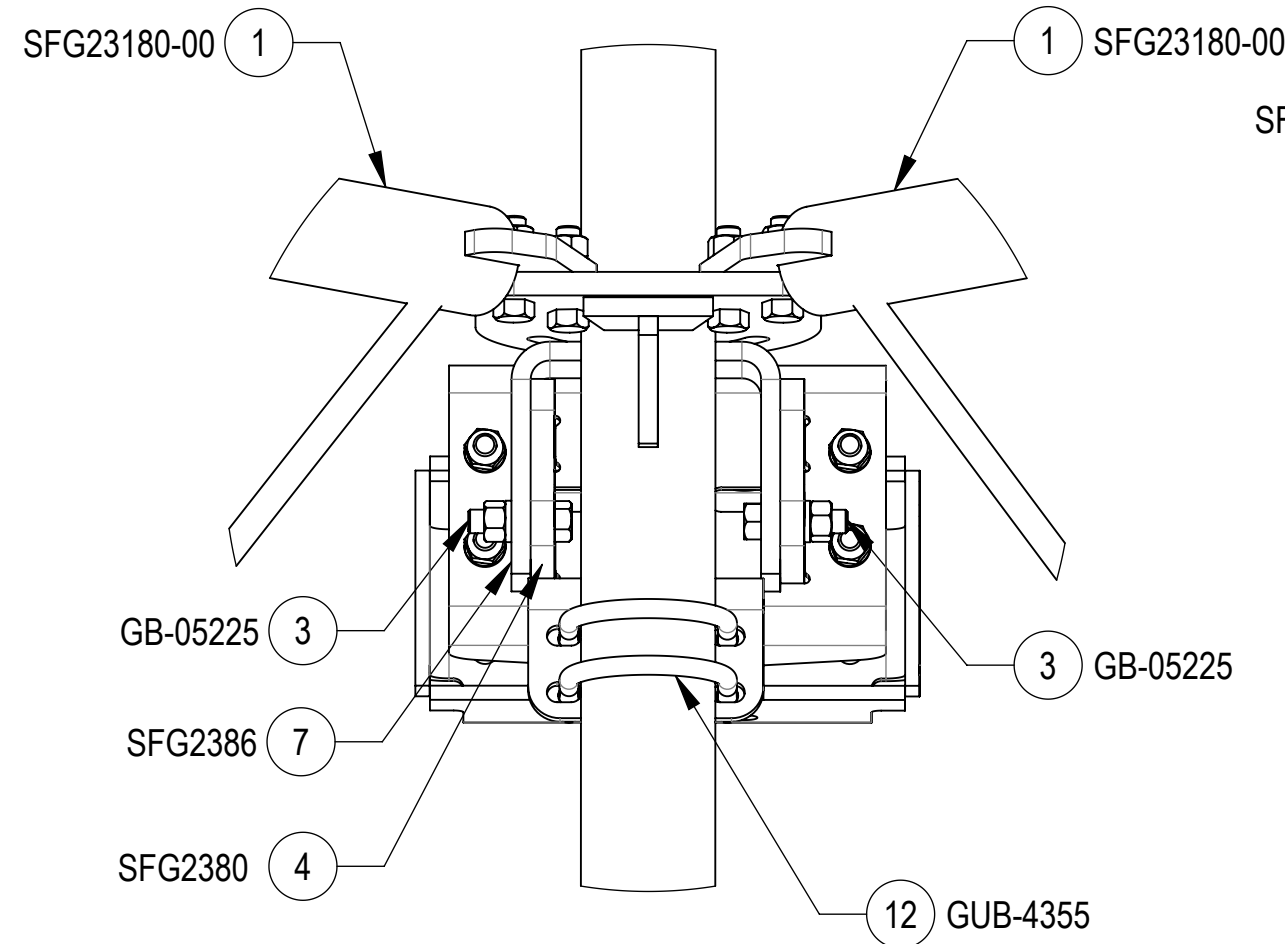

DETAIL ISO TOP ROTATED VIEW
SCALE 1 : 5

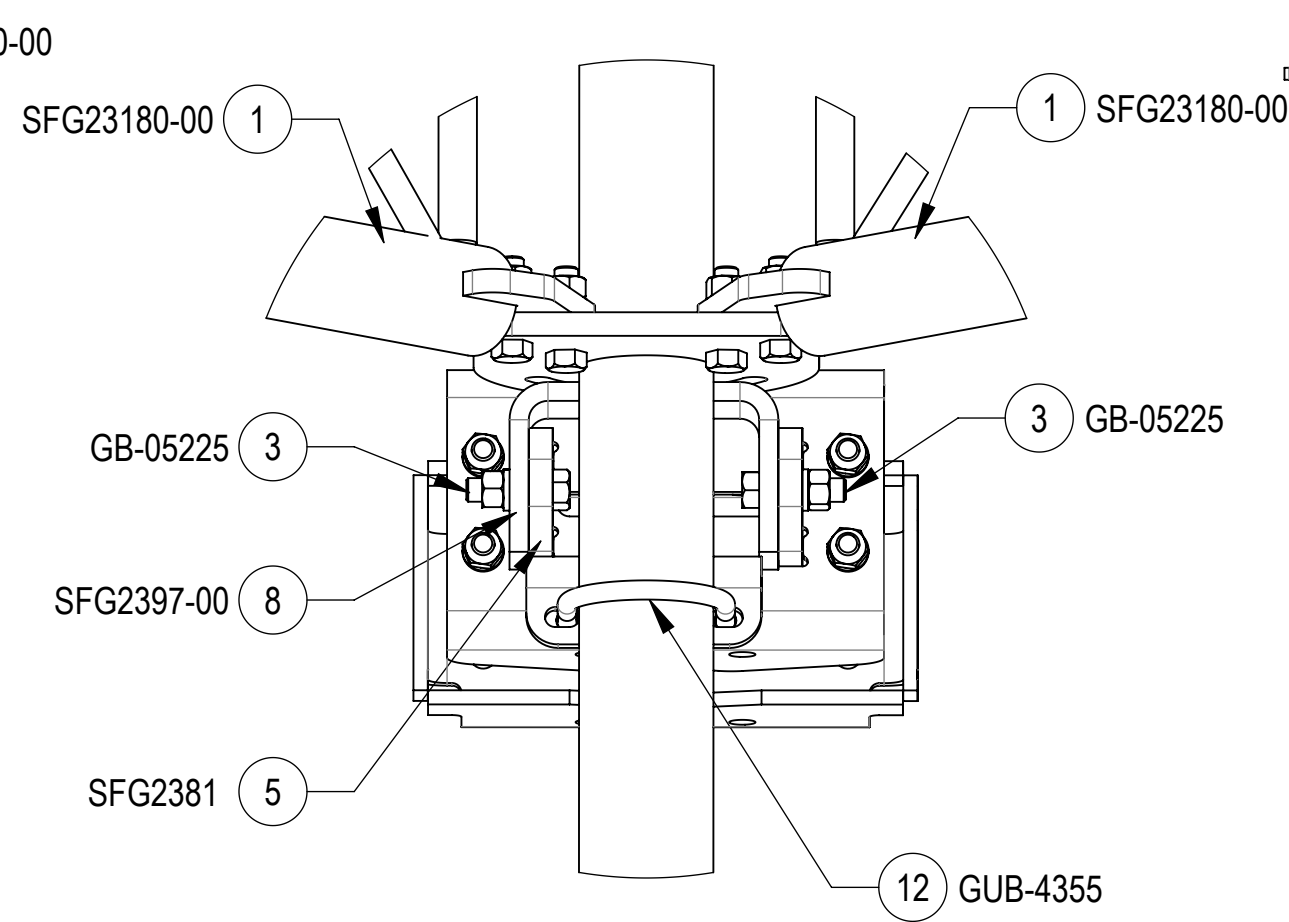

DETAIL ISO BOTTOM ROTATED VIEW
SCALE 1 : 5

COMMSCOPE, INC. OF NORTH CAROLINA				
TITLE SFG23RHDXL SECTOR FRAME SERIES				
SIZE C	SCALE 1:24	DOCUMENT NO. SFG23RHDXL		
DRAWING		REVISION		SHEET
VERSION 03	STATUS RE	REVISION D	9 OF 12	

4

3



2

1

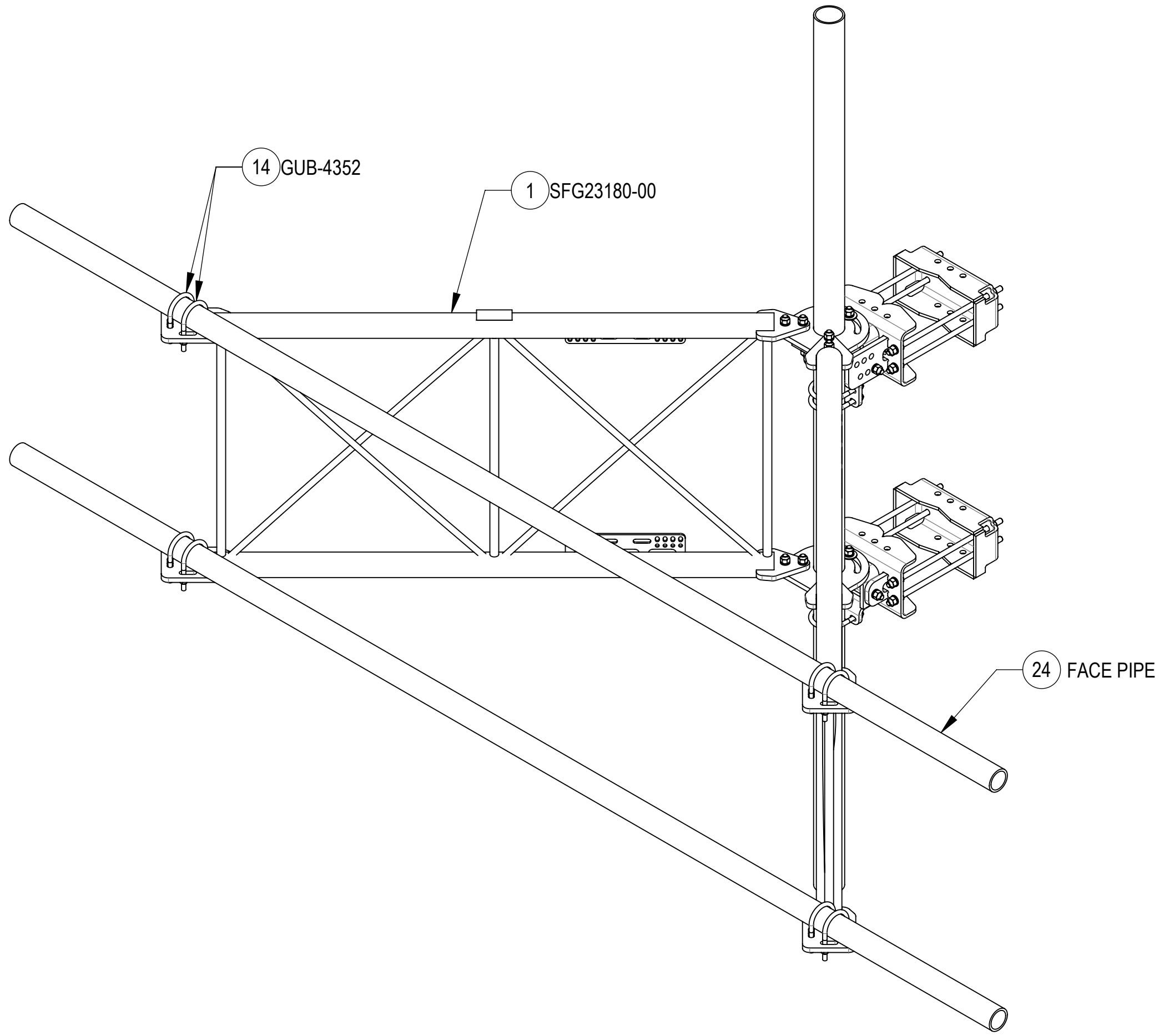
STEP 4: ATTACH FACE PIPES TO STANDOFF ARMS (SFG23180-00) USING U-BOLTS (GUB-4352)



TOP
 ↓
 BOTTOM

COMMSCOPE, INC. OF NORTH CAROLINA				
TITLE SFG23RHDXL SECTOR FRAME SERIES				
SIZE C	SCALE 1:24	DOCUMENT NO. SFG23RHDXL		
 		DRAWING		SHEET
		VERSION 03	STATUS RE	REVISION D

4

3

2

1

D

D

C

C

B

B

A

A

STEP 5: ATTACH ANTENNA PIPES TO FACE PIPES USING CROSSOVER PLATES KITS (XP-2525) .
 ATTACH TIE BACK PIPES (MT546120120) TO FACE PIPES USING ROUND CROSSOVER PLATES KITS (XP-R).

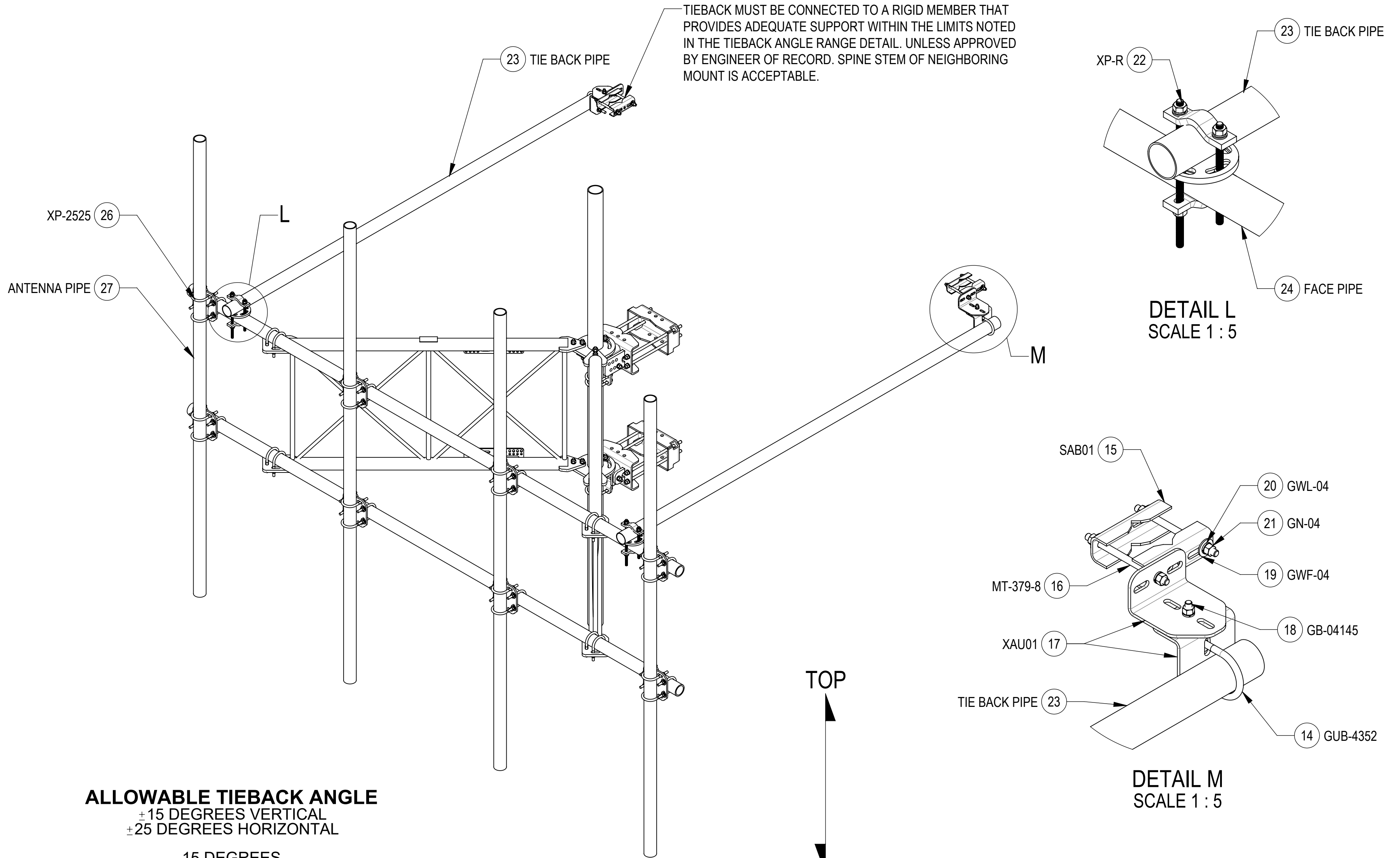

TOP
 ↓
 BOTTOM

ALLOWABLE TIEBACK ANGLE

± 15 DEGREES VERTICAL
 ± 25 DEGREES HORIZONTAL

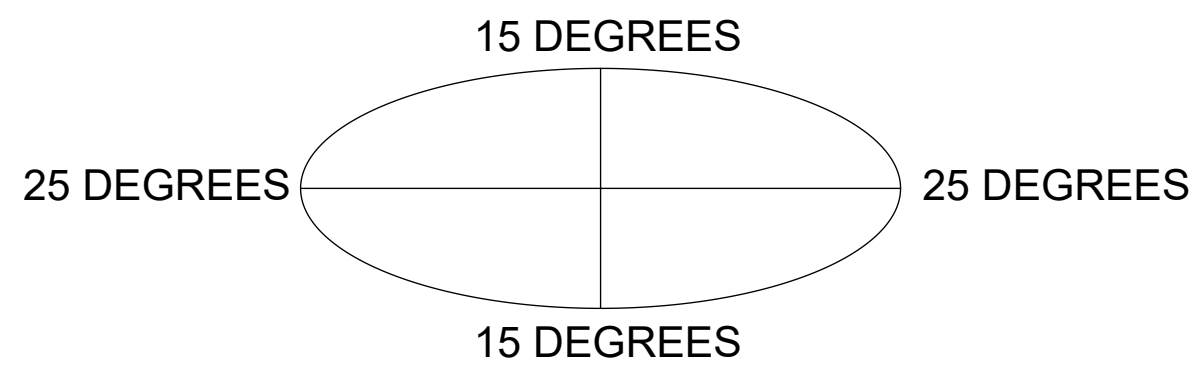

COMMSCOPE, INC. OF NORTH CAROLINA				
TITLE SFG23RHDXL SECTOR FRAME SERIES				
SIZE C	SCALE 1:24	DOCUMENT NO. SFG23RHDXL		
DRAWING		REVISION		SHEET
VERSION 03	STATUS RE	REVISION D	11 OF 12	

4

3

2

1

ACCESSORIES ORDERED SEPARATELY:

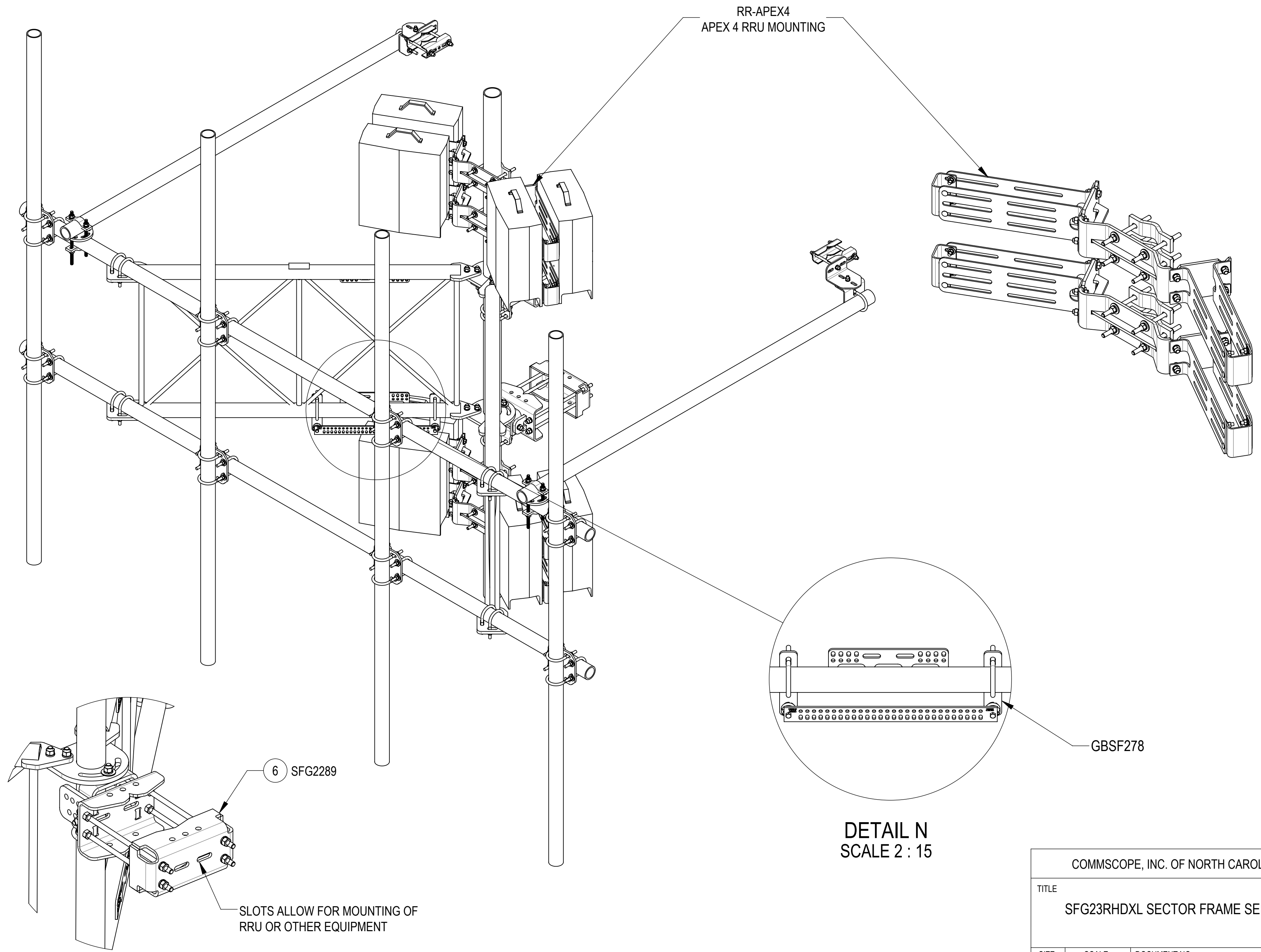

COMMSCOPE, INC. OF NORTH CAROLINA				
TITLE SFG23RHDXL SECTOR FRAME SERIES				
SIZE C	SCALE 1:12	DOCUMENT NO. SFG23RHDXL		
		DRAWING		SHEET
		VERSION 03	STATUS RE	REVISION D
				12 OF 12

4

3

2

1