

REVISION			
REV	DESCRIPTION	DATE	APPROVED
A	40202469CMO	16-AUG-2024	SA

NOTES :

- SEE COMMSCOPE CATALOG FOR COMPLETE LIST OF PARTS RELATED TO THE USE OF THIS PRODUCT.
- DIMENSIONS ARE IN MM.
- PART INCLUDES:
 (1) Panel with integrated rear cable manager.
 (1) Velcro, Set of 4.
 (2) M5 grounding points.
- ALL DIMENSIONS ARE REFERENCE DIMENSIONS.

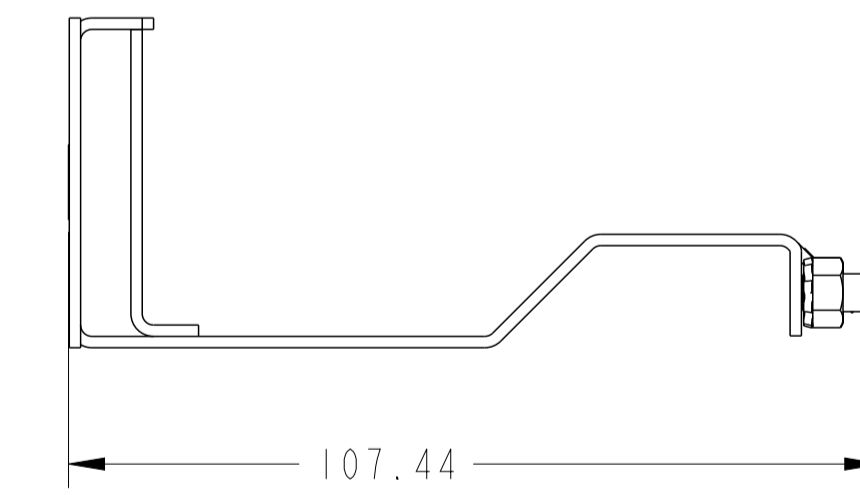
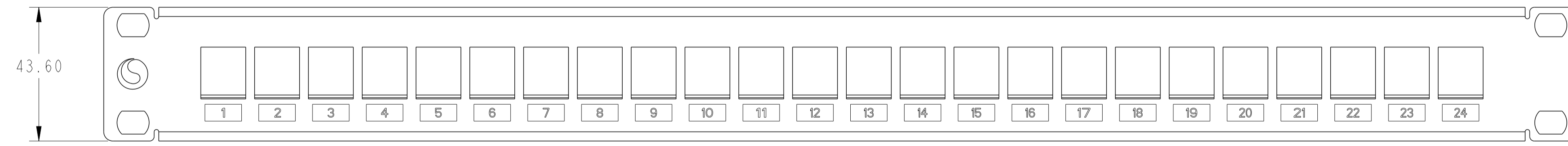
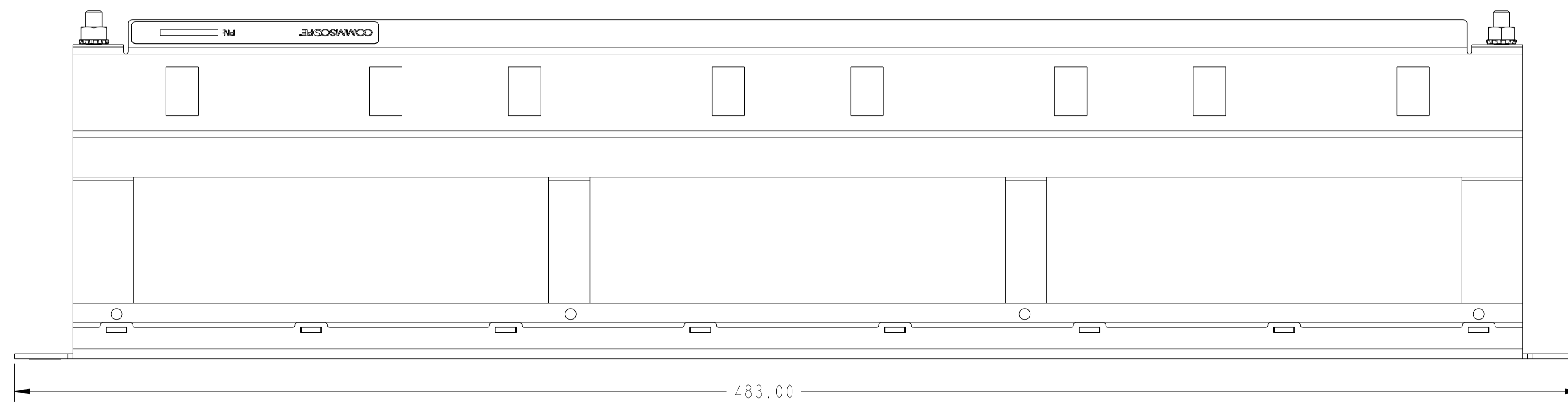
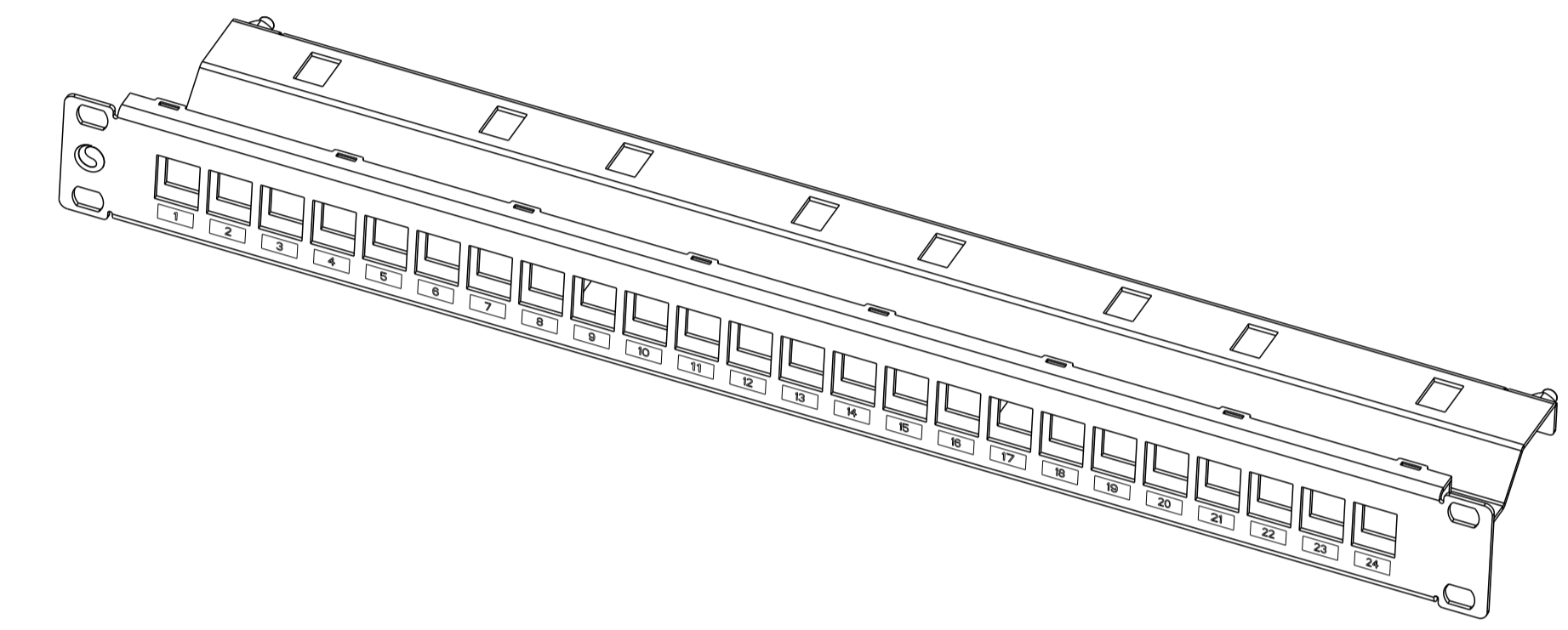

CPP-SMOD-SL-1U-E-24	760256625
CATALOG NUMBER	MATERIAL ID

COMMSCOPE, INC.			
DRAFTER W. PRASANNA	TITLE CPP-MODULAR-PANEL		
ENGINEER A. SANDESH	SIZE A1	SCALE 0.500	DOCUMENT NO. 760256625-C
CUSTOMER DRAWING			REVISION SHEET A 1 OF 1