

4

3

2

1

- 1.0 GENERAL NOTES
 - 1.1 ALL METRIC DIMENSIONS ARE IN BRACKETS [X. X]
 - 1.2 FOR PATENT INFO: <https://www.cs-pat.com>

- 2.0 DESIGN NOTES
 - 2.1 ANY HAZARDS OR OBSTRUCTIONS TO THE CLIMBING FACILITY AND SAFETY CLIMB MUST BE IDENTIFIED PRIOR TO INSTALLING THE APPURTENANCE. ADDITIONAL PRODUCTS MAY BE REQUIRED TO MAINTAIN THE INTEGRITY OF THE SAFETY CLIMB. DURING INSTALLATION, TEMPORARY AND/OR PERMANENT PRECAUTIONARY MEASURES SHOULD BE TAKEN TO PRESERVE THE CLIMBING FACILITY AND/OR SAFETY CLIMB.

D **2.2** FITS MONOPOLES 28" TO 50" OD. MONOPOLE DIAMETER MUST BE GREATER THAN OR EQUAL TO 28" TO MEET ANTENNA TO ANTENNA CORNER SPACING OF >24".

- 3.0 MANUFACTURING/SPECIAL REQUIREMENTS
 - 3.1 TIGHTEN ALL BOLTS SECURING FLAT PLATES BY THE TURN-OF-NUT METHOD. TIGHTEN ALL U-BOLTS USING TURN-OF-NUT METHOD WITH ATTENTION TO LEAVE EQUAL DISTANCE AND EQUAL FORCE ON EACH LEG OF THE U-BOLT.

- 4.0 TEST
- 5.0 PACKAGING
 - 5.1 PACKAGING SHALL MEET COMMSCOPE REQUIREMENTS PER DOCUMENT IS-PL-3005.
 - 5.2 PRINTED DOCUMENT TO BE PLACED INSIDE POLYBAG AND THEN IN SHIPPING CONTAINER.
 - 5.3 EXTRA HARDWARE MAY BE SUPPLIED, BAGGED AND SHIPPED.

REVISIONS			
REV.	DESCRIPTION	DATE	APPROVED
A	INITIAL RELEASE	JL1183 18FEB24	CB1094 40188553CMO

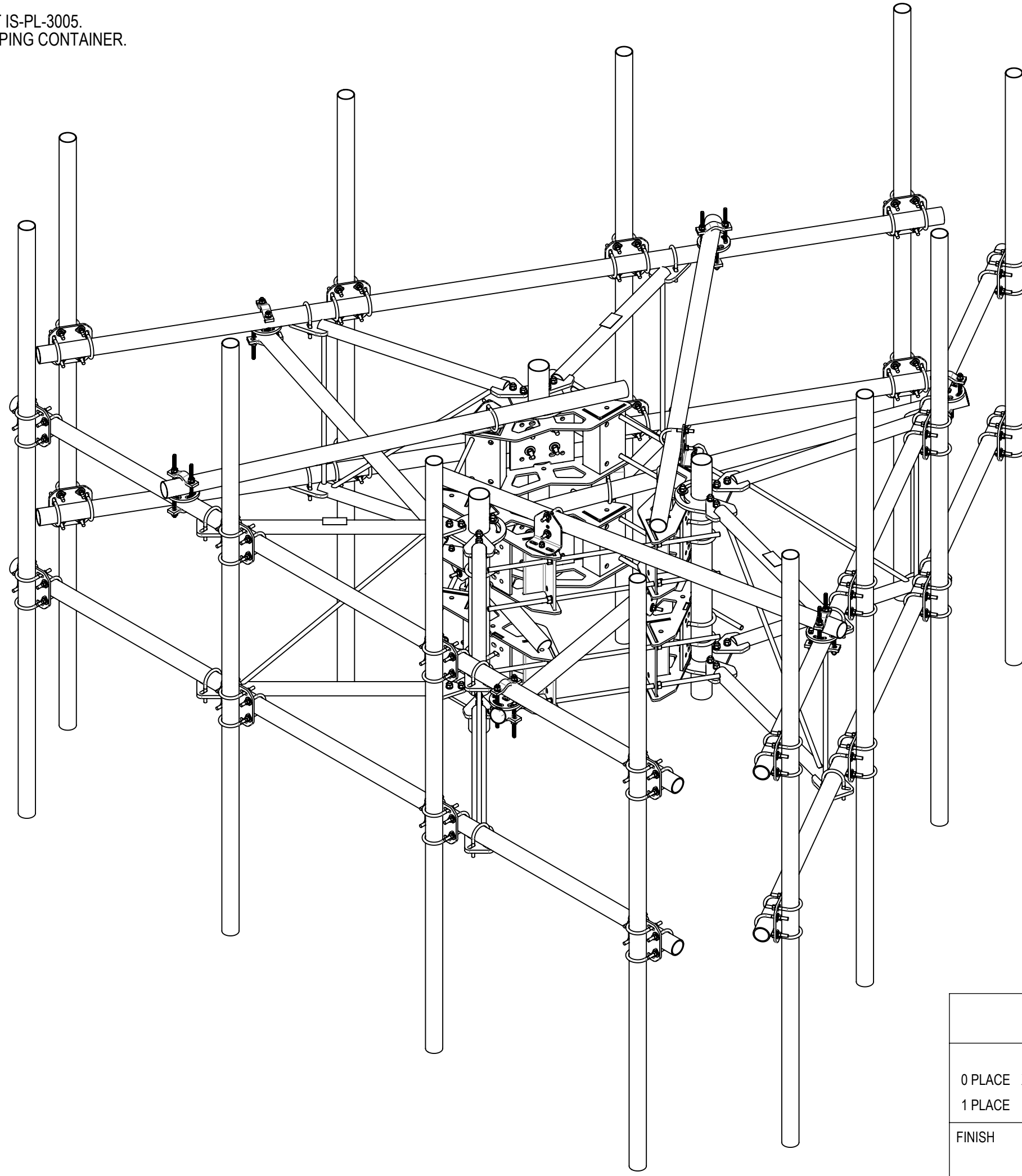

COMMSCOPE, INC. OF NORTH CAROLINA

TOLERANCES		SAP MATERIAL MASTER						
0 PLACE X[X] ± 0.25[6.3]	2 PLACE .XX[X] ± 0.06[1.5]	MCG22HDX13-12-H10						
1 PLACE X[X] ± 0.12[3.0]	ANGLES ± 2°							
FINISH		MATERIAL						
UNLESS OTHERWISE SPECIFIED DIMENSIONS ARE IN INCHES INTERPRET PER ANSI Y 14.5M-1994		NAME	DATE	MP, 13' SF KIT OF 3 W/COLLAR, AP				
		CE JL1183	18FEB24					
		RW JL1183	02/28/2024					
		AD YMENG	02/28/2024					
		RE JL1183	02/28/2024	SCALE	DOCUMENT NO.	MCG22HDX13-12-H10		
ECN 40188553CMO		1:18						
SIZE	Auth Group	INSL	MODEL	DRAWING	SHEET			
C		00	RE	A	00	RE	A	1 OF 4

DENSITY		lbs/in³
MASS	2148.78	lbs
VOLUME	8883.36	in³
SURFACE AREA	86320.60	in²
HEIGHT	120"	
LENGTH	156"	
WIDTH	84"	

4

3

2

1

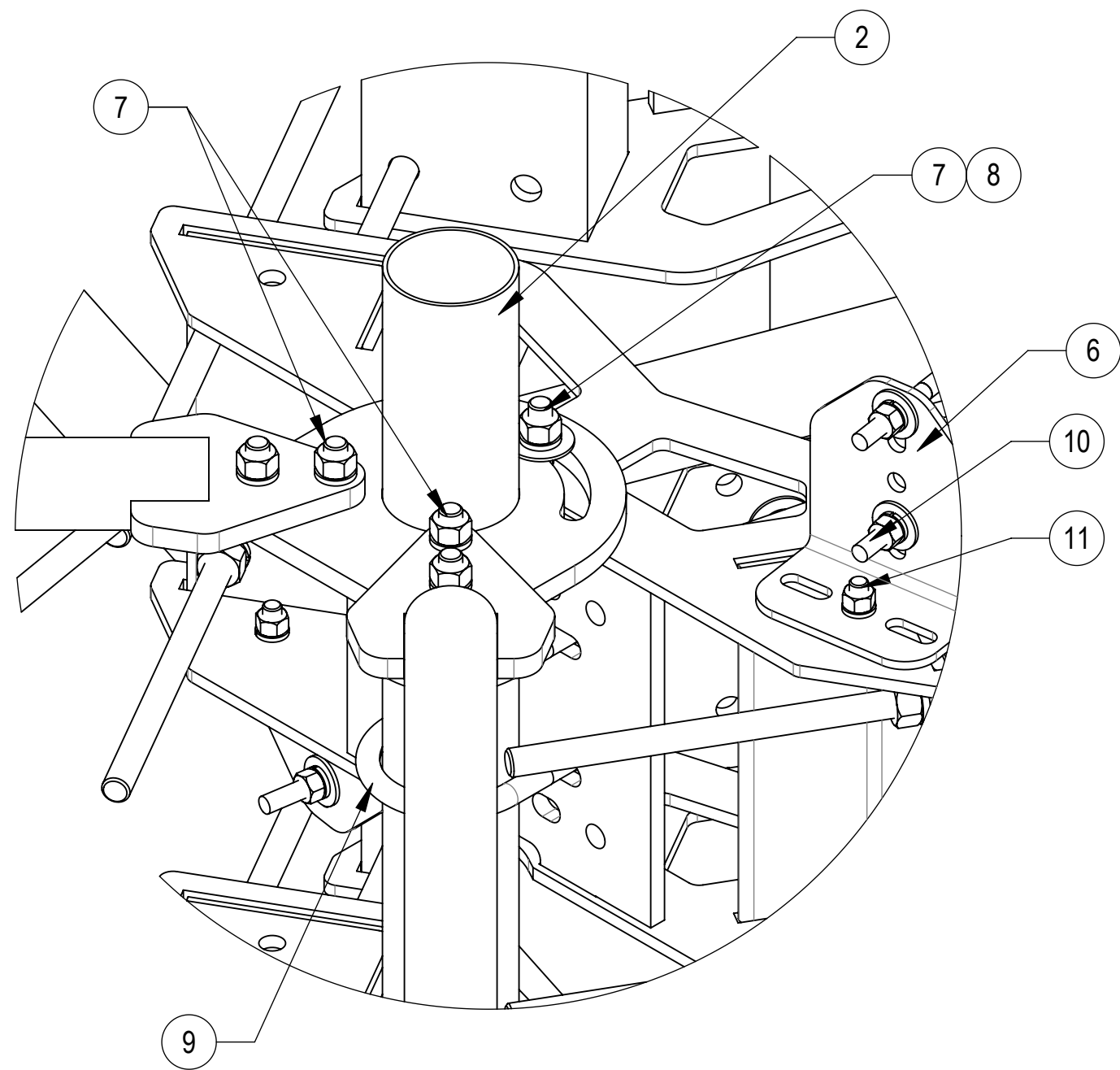

DETAIL B
SCALE 1:4

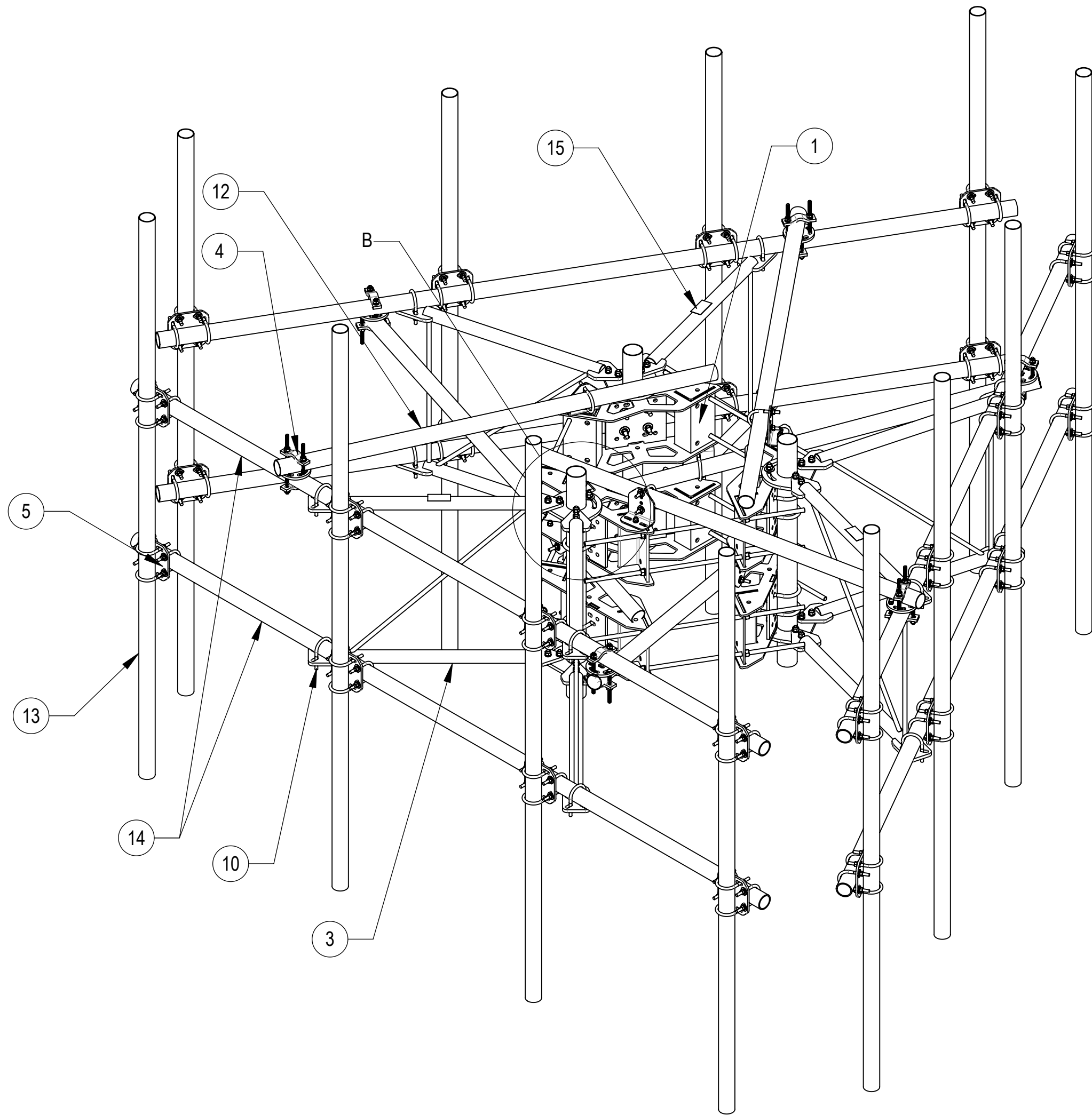

COMPONENT PART NUMBERS PROVIDED FOR ASSEMBLY PURPOSES;
INDIVIDUAL COMPONENTS MAY BE SHIPPED AS PARTS WITHIN AN INCLUDED KIT.

ITEM	PART NO.	DESCRIPTION	QTY.	WEIGHT	NOTE NO.
1	MC-RM1550-3	15" - 50" OD RINGMOUNT	2	229.90 LBS	
2	SFG2270	BACK VERTICAL ARM MOUNT	3	36.96 LBS	
3	SFG2278	ARM, STANDOFF - SFG22	6	40.92 LBS	
4	XP-R	CROSSOVER PLATE, ROUND, UP TO 3.5" OD	6	6.20 LBS	
5	XP-2525	CROSSOVER PLATE KIT, 2-7/8 OD X 2-7/8 OD	24	8.37 LBS	
6	XAU01	ANGLE, CROSSOVER, 1.9-3.5" X 1.9-3.5" OD	6	2.98 LBS	
7	GB-05225	5/8" X 2-1/4" GALV BOLT KIT	30	0.28 LBS	
8	GWF-05	5/8" GALV FLAT WASHER, 1.7OD	6	0.06 LBS	
9	GUB-53560	5/8" X 3-5/8" X 6" GALV U-BOLT	12	1.30 LBS	
10	GUB-4352	1/2" X 3" X 5-1/4" GALV U-BOLT	18	0.71 LBS	
11	GB-04145	1/2" X 1-1/2" GALV BOLT KIT	6	0.13 LBS	
12	MT546084120	2.88" OD X 84" LONG PIPE	6	24.81 LBS	
13	MT546120120	PIPE, 2.875"OD X 120"	12	35.44 LBS	
14	MT546156	2.875" O.D. X 156" PIPE	6	75.58 LBS	
15	SFG2255	LABEL, SFG22HDX	3	0.04 LBS	

ALLOWABLE TIEBACK ANGLE

± 15 DEGREES VERTICAL
± 25 DEGREES HORIZONTAL

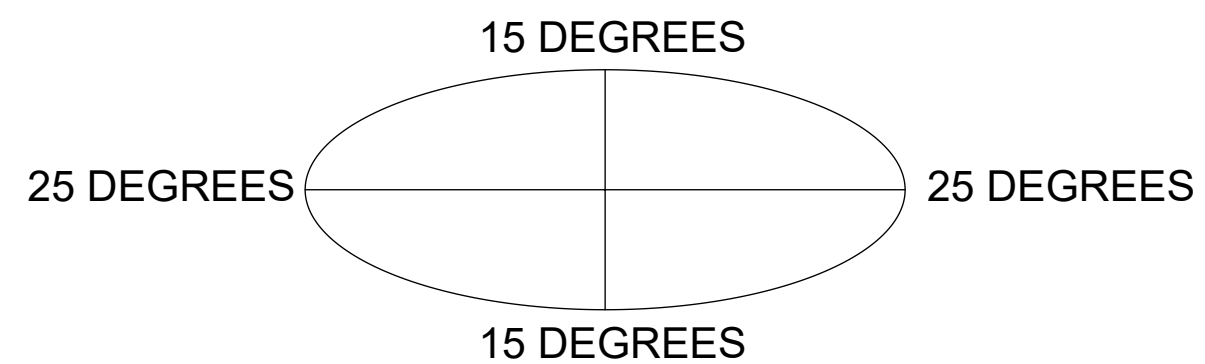

© 2024 CommScope, Inc. Confidential

COMMSCOPE, INC. OF NORTH CAROLINA				
TITLE MP, 13' SF KIT OF 3 W/COLLAR, AP				
SIZE C	SCALE 1:18	DOCUMENT NO. MCG22HDX13-12-H10		
DRAWING		VERSION	STATUS	REVISION
		00	RE	A
				SHEET 2 OF 4

4

3

2

1

ALLOWABLE TIEBACK ANGLE

+15 DEGREES VERTICAL
±25 DEGREES HORIZONTAL

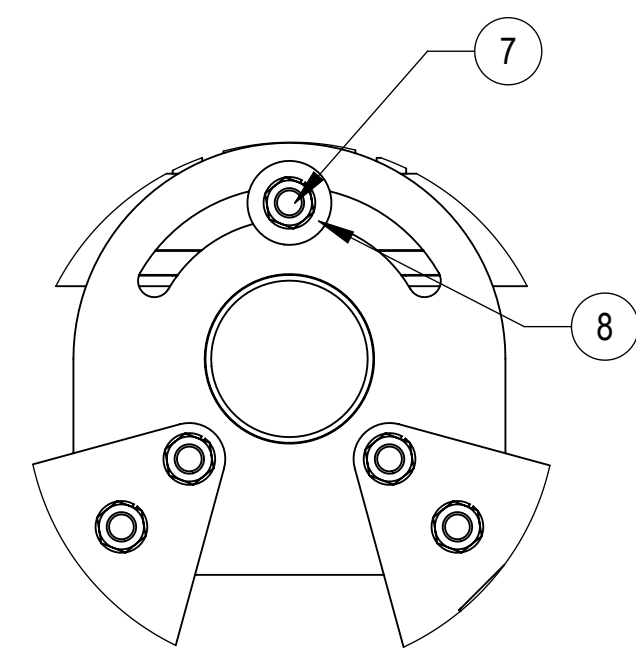
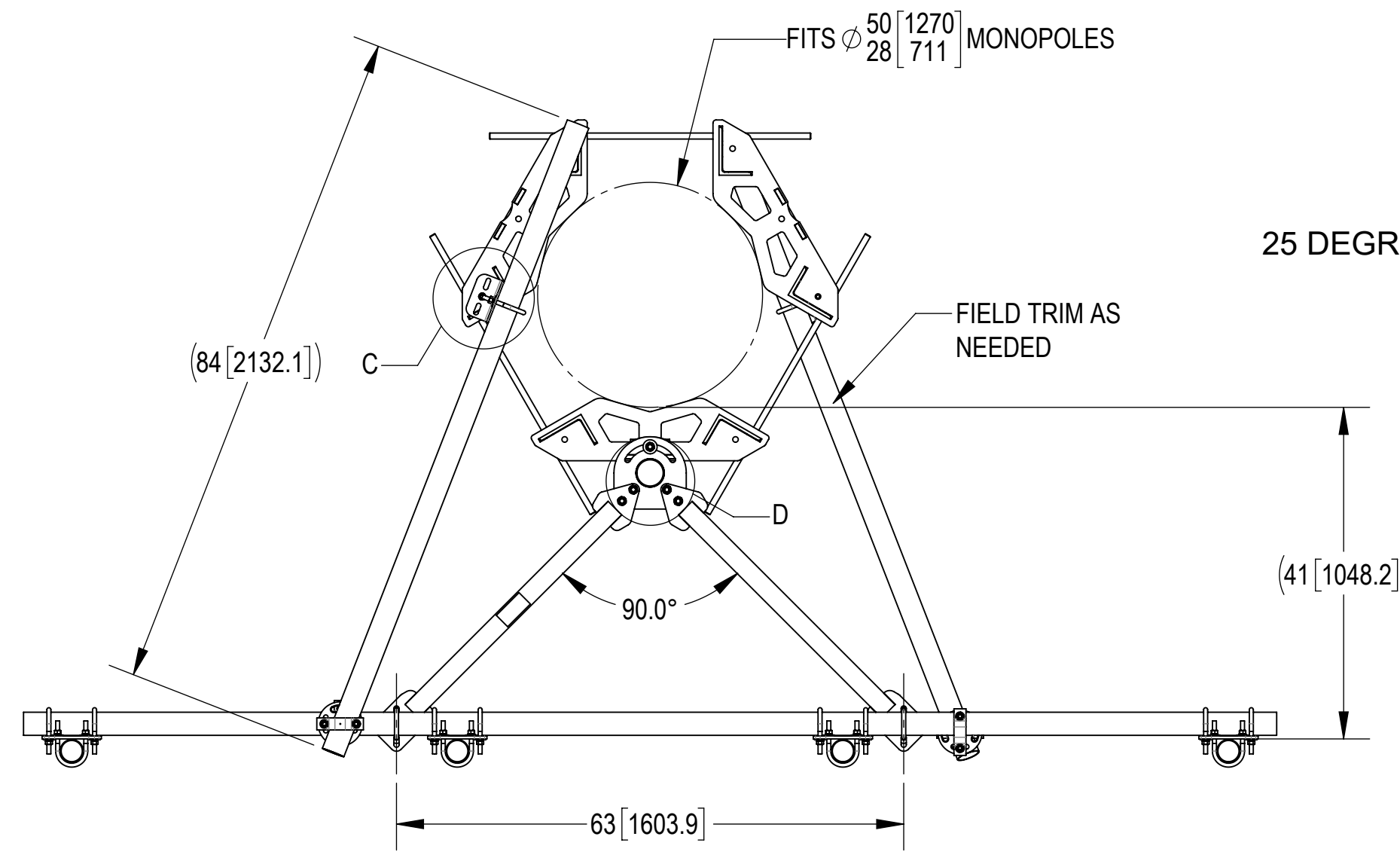
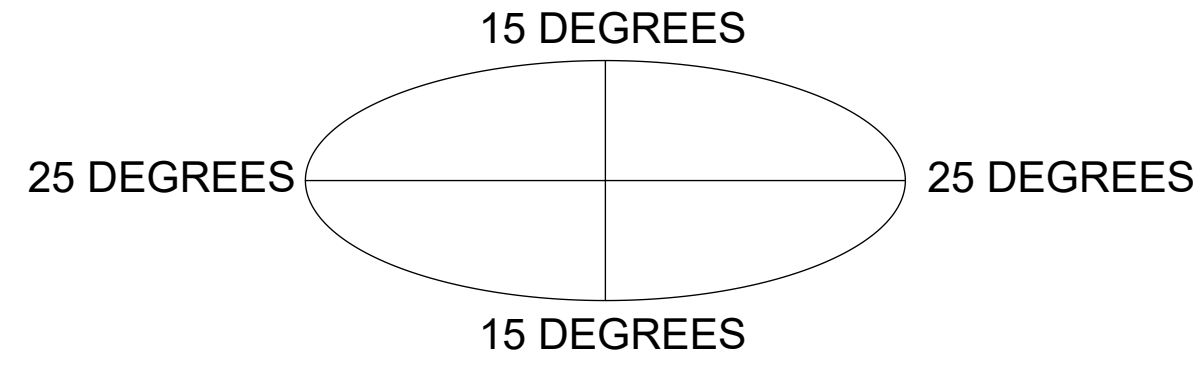

DETAIL D
SCALE 1 : 4

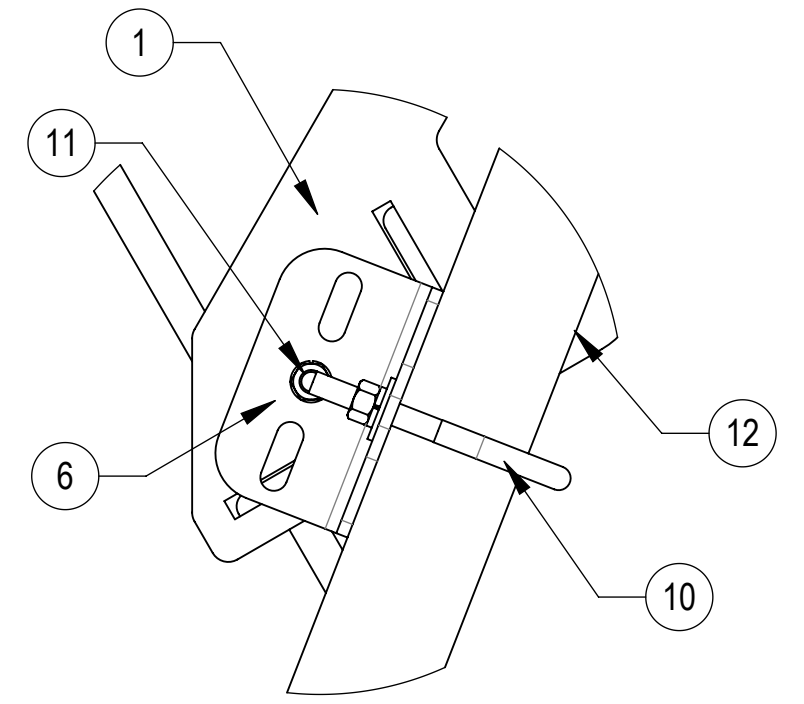

DETAIL C
SCALE 1 : 4

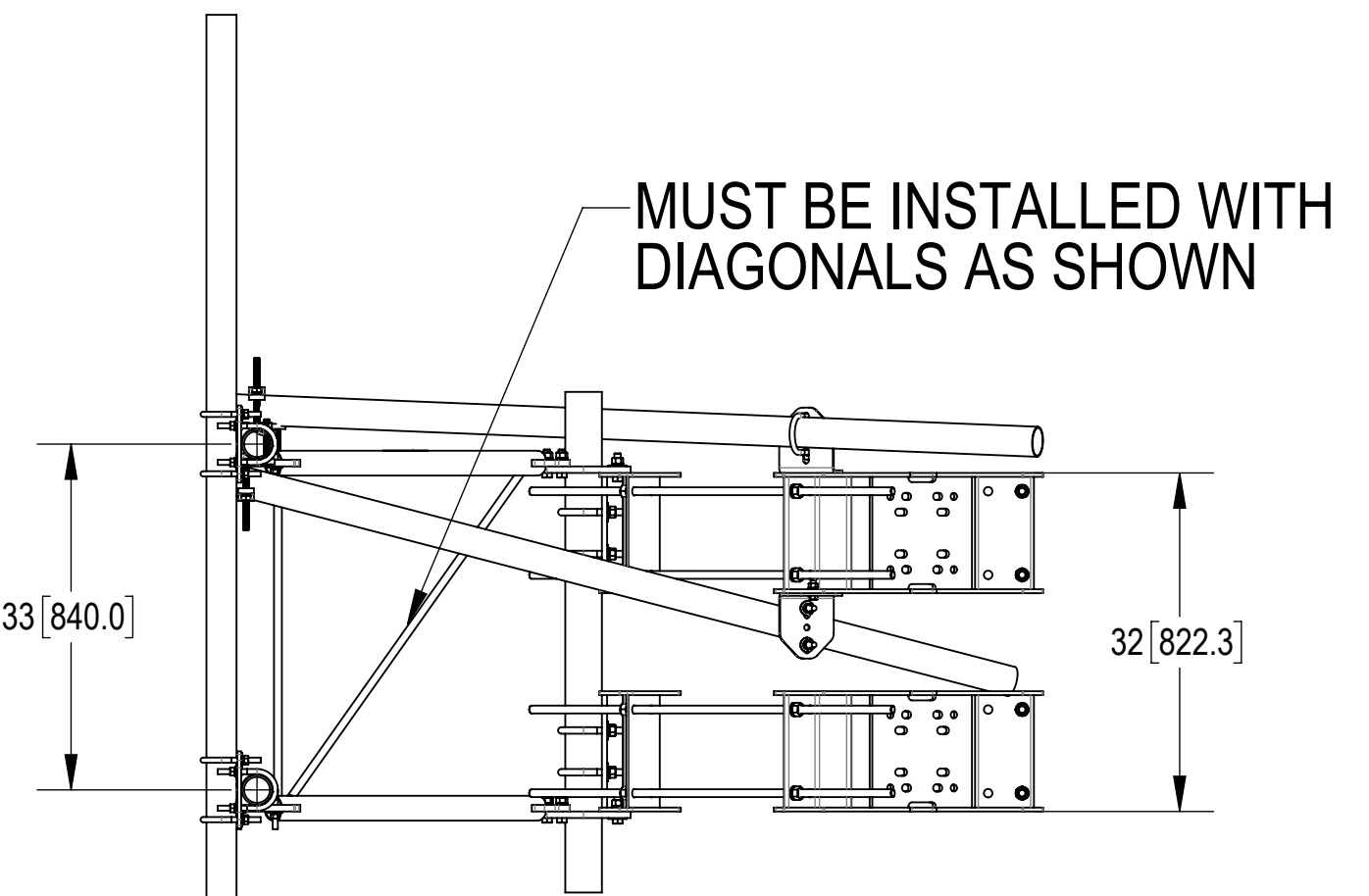
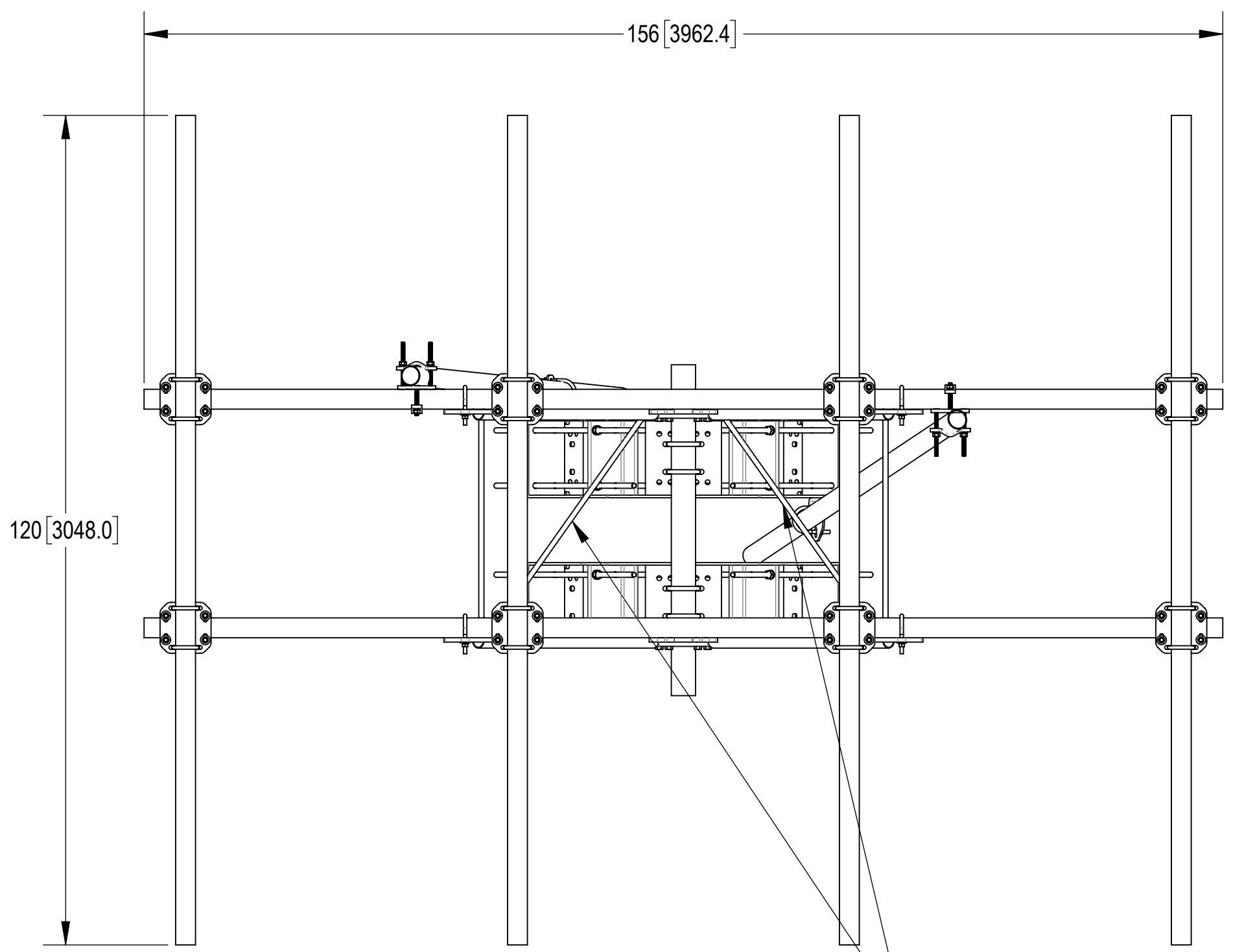

TOP
BOTTOM

MUST BE INSTALLED WITH
DIAGNALS AS SHOWN

SOME ITEMS OMITTED FOR CLARITY

COMMSCOPE, INC. OF NORTH CAROLINA				
TITLE MP, 13' SF KIT OF 3 W/COLLAR, AP				
SIZE C	SCALE 1:18	DOCUMENT NO. MCG22HDX13-12-H10		
		DRAWING		SHEET
		VERSION	STATUS	REVISION
		00	RE	A
				3 OF 4

4

3

2

1

ANTENNA SPACING SHOWN

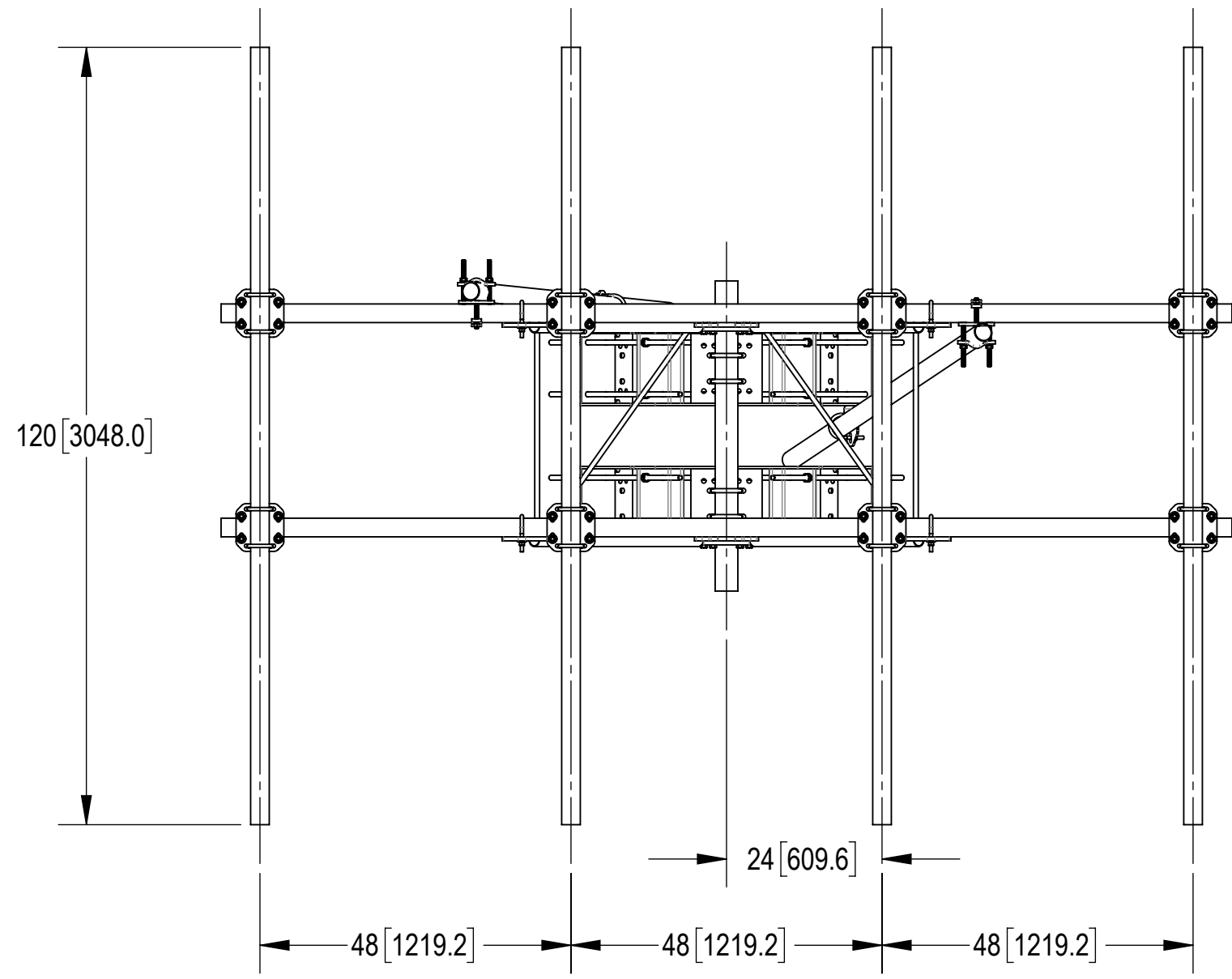
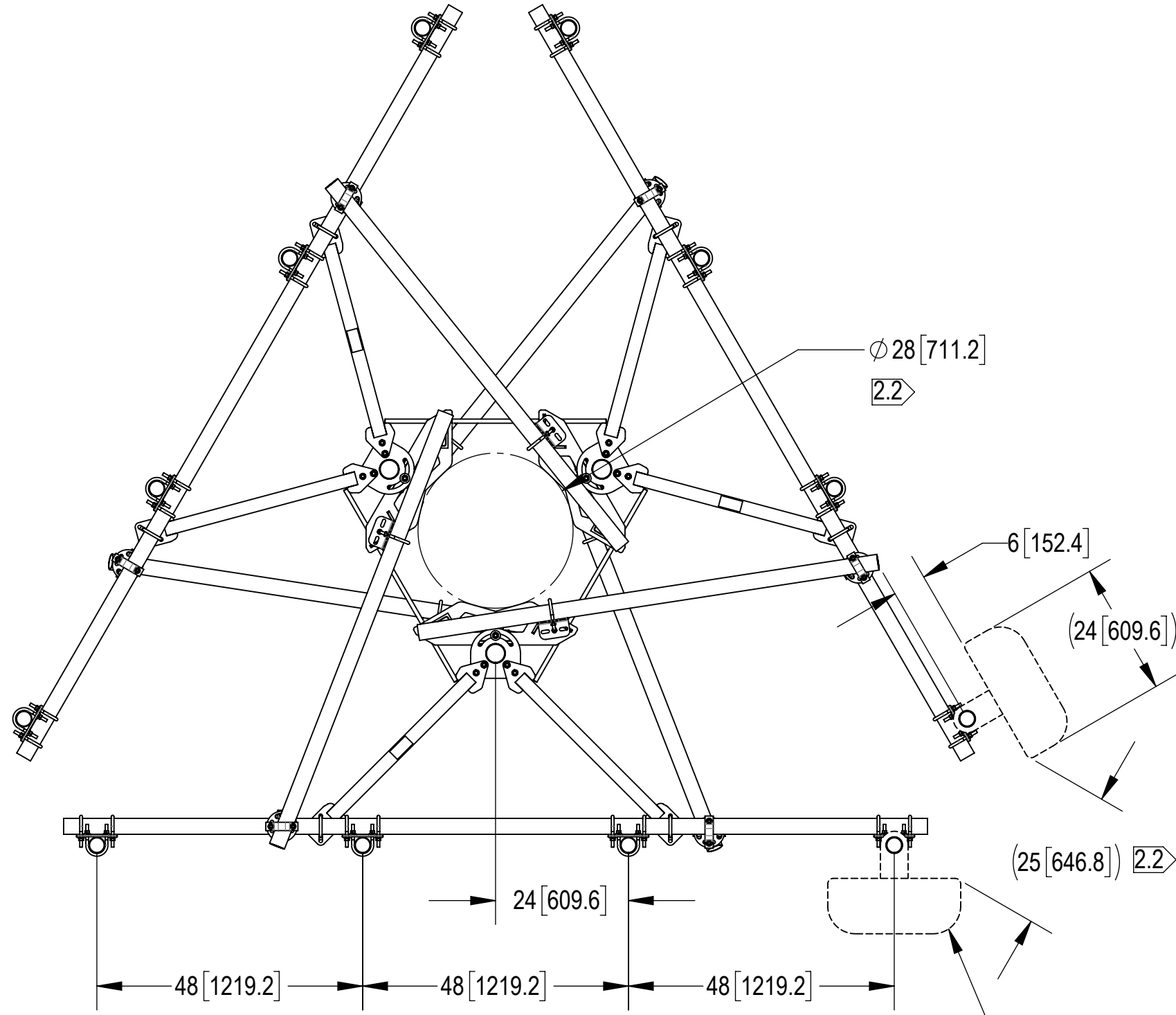

SOME ITEMS OMITTED FOR CLARITY

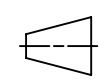
COMMSCOPE, INC. OF NORTH CAROLINA				
TITLE MP, 13' SF KIT OF 3 W/COLLAR, AP				
SIZE C	SCALE 1:24	DOCUMENT NO. MCG22HDX13-12-H10		
 		DRAWING		SHEET
		VERSION 00	STATUS RE	REVISION A