

4

3

2

1

- 1.0 GENERAL NOTES
  - 1.1 ALL METRIC DIMENSIONS ARE IN BRACKETS [X. X]
  - 1.2 FOR PATENT INFO: <https://www.cs-pat.com>

- 2.0 DESIGN NOTES
  - 2.1 ANY HAZARDS OR OBSTRUCTIONS TO THE CLIMBING FACILITY AND SAFETY CLIMB MUST BE IDENTIFIED PRIOR TO INSTALLING THE APPURTENANCE. ADDITIONAL PRODUCTS MAY BE REQUIRED TO MAINTAIN THE INTEGRITY OF THE SAFETY CLIMB. DURING INSTALLATION, TEMPORARY AND/OR PERMANENT PRECAUTIONARY MEASURES SHOULD BE TAKEN TO PRESERVE THE CLIMBING FACILITY AND/OR SAFETY CLIMB.

D **2.2** FITS MONOPOLES 45" TO 50" OD. MONOPOLE DIAMETER MUST BE GREATER THAN OR EQUAL TO 45" TO MEET ANTENNA TO ANTENNA CORNER SPACING OF >24".

- 3.0 MANUFACTURING/SPECIAL REQUIREMENTS
  - 3.1 TIGHTEN ALL BOLTS SECURING FLAT PLATES BY THE TURN-OF-NUT METHOD. TIGHTEN ALL U-BOLTS USING TURN-OF-NUT METHOD WITH ATTENTION TO LEAVE EQUAL DISTANCE AND EQUAL FORCE ON EACH LEG OF THE U-BOLT.

- 4.0 TEST
- 5.0 PACKAGING
  - 5.1 PACKAGING SHALL MEET COMMSCOPE REQUIREMENTS PER DOCUMENT IS-PL-3005.
  - 5.2 PRINTED DOCUMENT TO BE PLACED INSIDE POLYBAG AND THEN IN SHIPPING CONTAINER.
  - 5.3 EXTRA HARDWARE MAY BE SUPPLIED, BAGGED AND SHIPPED.

REVISIONS			
REV.	DESCRIPTION	DATE	APPROVED
A	INITIAL RELEASE	JL1183 18FEB24	CB1094 40188553CMO

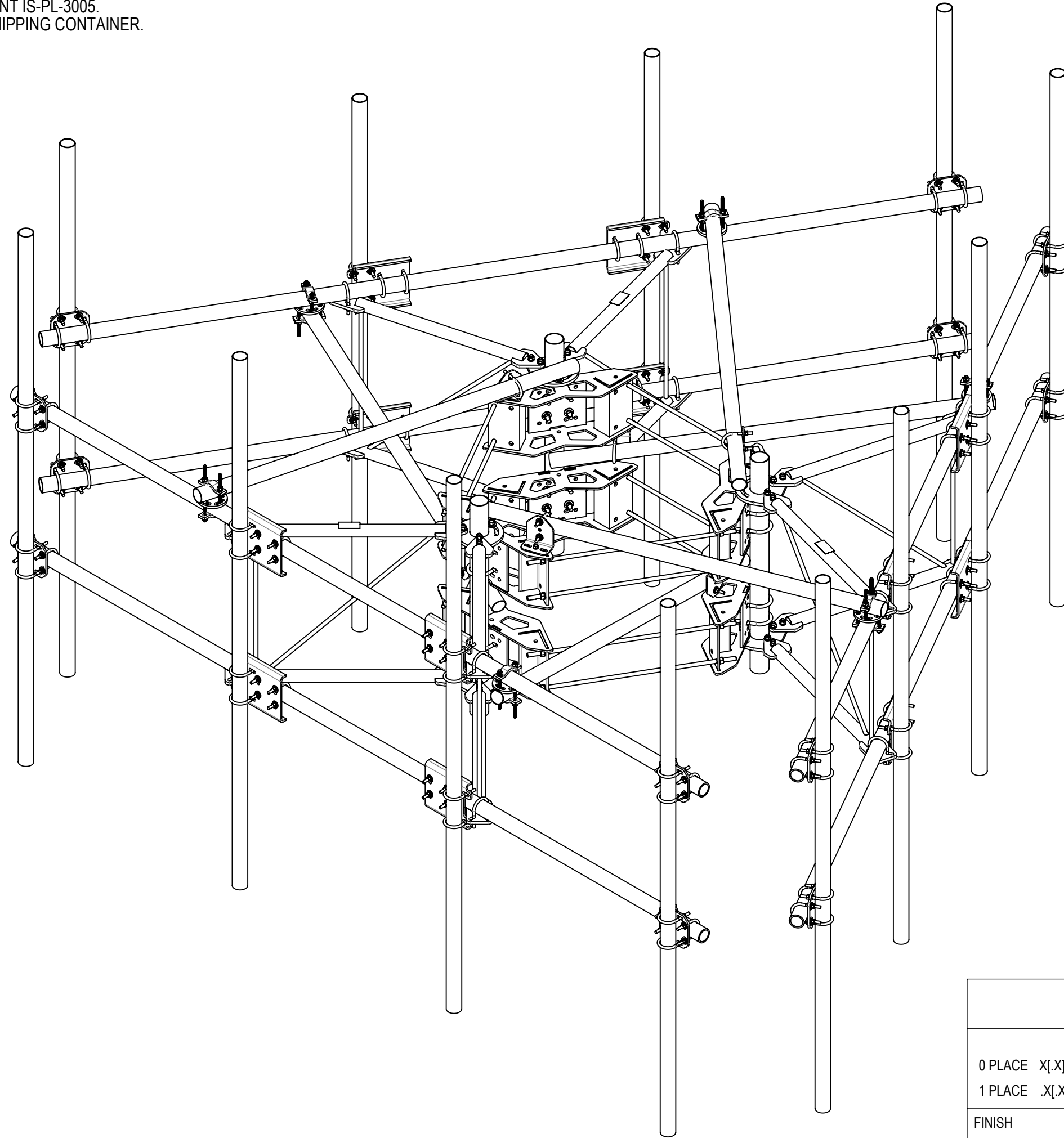

**COMMSCOPE, INC. OF NORTH CAROLINA**

TOLERANCES		SAP MATERIAL MASTER				
0 PLACE X[X] ± 0.25[6.3]	2 PLACE .XX[X] ± 0.06[1.5]	<b>MCG22HDX15-12-H10</b>				
1 PLACE X[X] ± 0.12[3.0]	ANGLES ± 2°					
FINISH		MATERIAL				
<small>UNLESS OTHERWISE SPECIFIED DIMENSIONS ARE IN INCHES INTERPRET PER ANSI Y 14.5M-1994</small>		NAME	DATE	<b>MP, 15' SF KIT OF 3 W/COLLAR, AP</b>		
		CE JL1183	18FEB24			
		RW JL1183	02/28/2024			
		AD YMENG	02/28/2024			
		RE JL1183	02/28/2024			
ECN 40188553CMO		SCALE	DOCUMENT NO.	<b>MCG22HDX15-12-H10</b>		
		<b>1:20</b>				
SIZE	Auth Group	INSL	MODEL	DRAWING		SHEET 1 OF 4
<b>C</b>			VERSION STATUS REVISION	VERSION STATUS REVISION		
			00 RE A	00 RE A		

DENSITY		lbs/in³
MASS	2486.55	lbs
VOLUME	10875.58	in³
SURFACE AREA	93544.08	in²
HEIGHT	120"	
LENGTH	180"	
WIDTH	84"	

4

3

2

1

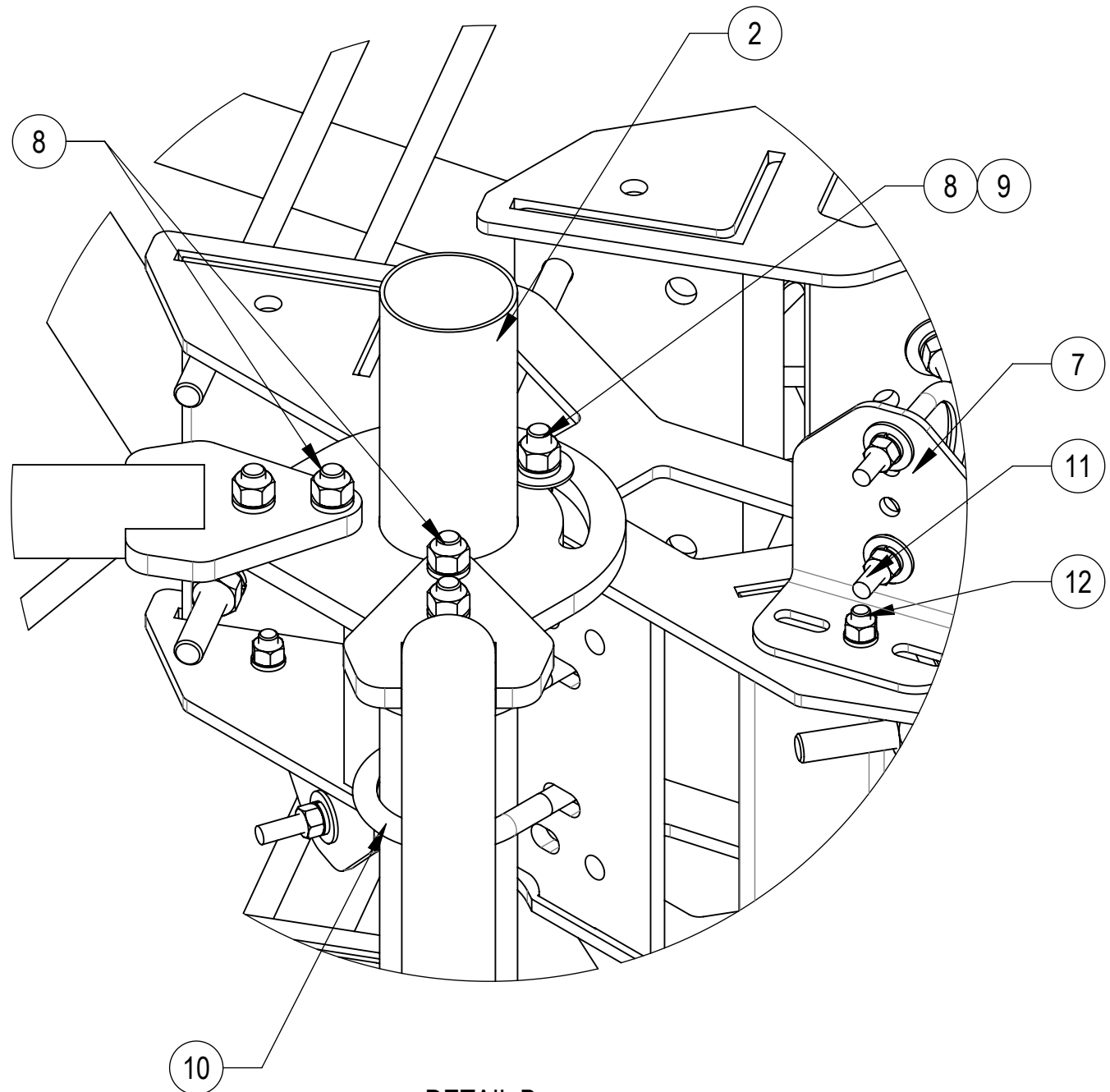

DETAIL B  
SCALE 1 : 4

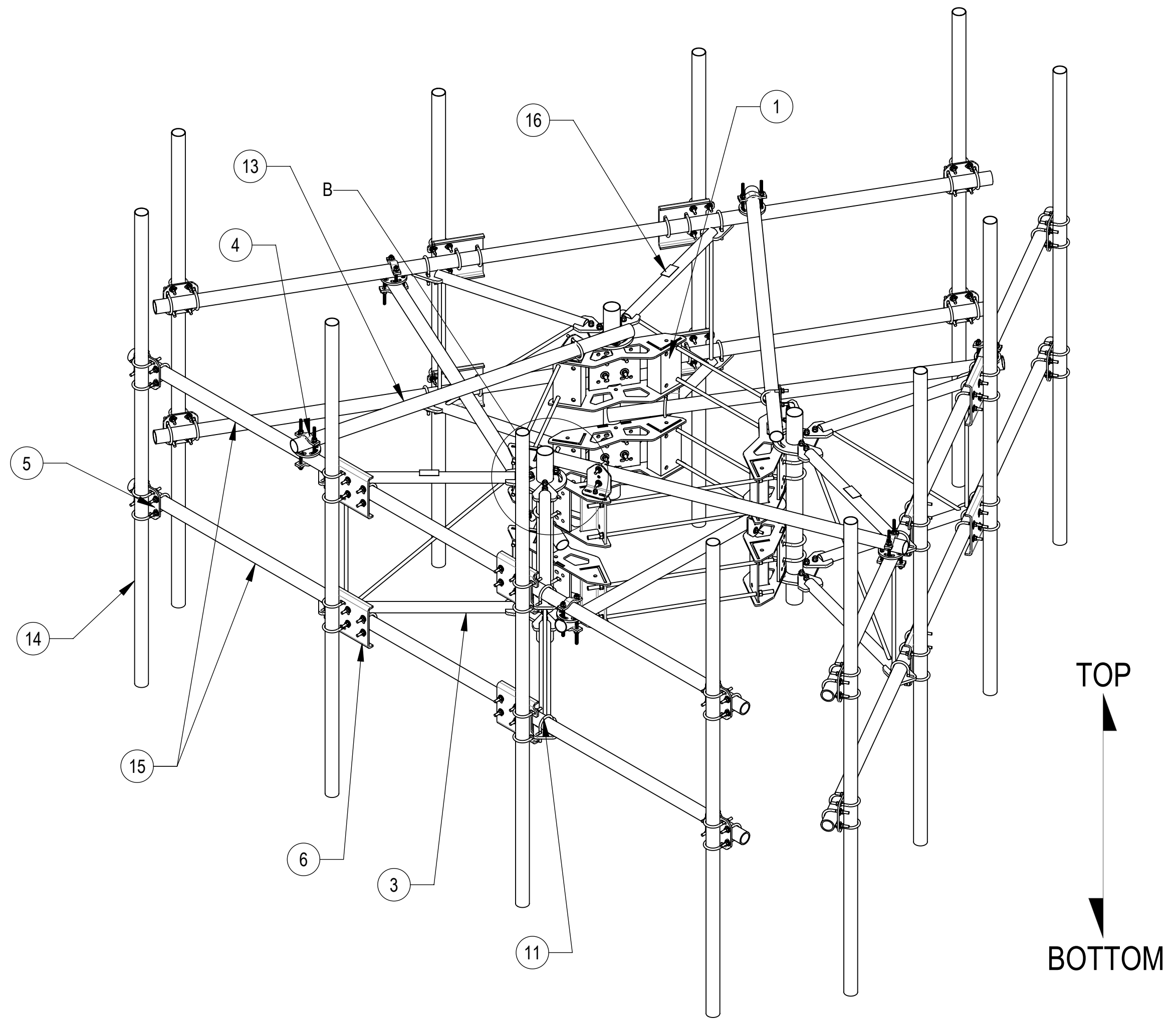

**ALLOWABLE TIEBACK ANGLE**  
± 15 DEGREES VERTICAL  
± 25 DEGREES HORIZONTAL

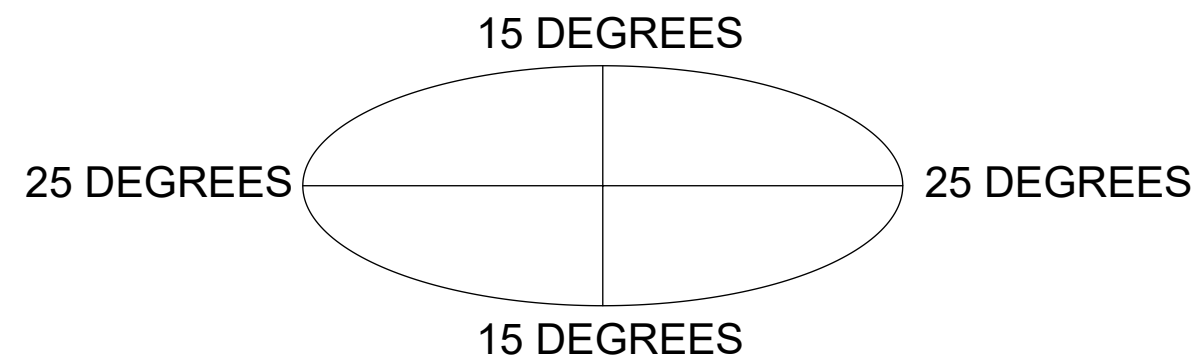

COMPONENT PART NUMBERS PROVIDED FOR ASSEMBLY PURPOSES;  
INDIVIDUAL COMPONENTS MAY BE SHIPPED AS PARTS WITHIN AN INCLUDED KIT.

ITEM	PART NO.	DESCRIPTION	QTY.	WEIGHT	NOTE NO.
1	MC-RM1550-3	15" - 50" OD RINGMOUNT	2	229.90 LBS	
2	SFG2270	BACK VERTICAL ARM MOUNT	3	36.96 LBS	
3	SFG2278	ARM, STANDOFF - SFG22	6	40.92 LBS	
4	XP-R	CROSSOVER PLATE, ROUND, UP TO 3.5" OD	6	6.20 LBS	
5	XP-2525	CROSSOVER PLATE KIT, 2-7/8 OD X 2-7/8 OD	12	8.37 LBS	
6	XP-2525-OFF	OFFSET CO PLATE KIT, 2-7/8ODX2-7/8OD	12	16.64 LBS	
7	XAU01	ANGLE, CROSSOVER, 1.9-3.5" X 1.9-3.5" OD	6	2.98 LBS	
8	GB-05225	5/8" X 2-1/4" GALV BOLT KIT	30	0.28 LBS	
9	GWF-05	5/8" GALV FLAT WASHER, 1.7OD	6	0.06 LBS	
10	GUB-53560	5/8" X 3-5/8" X 6" GALV U-BOLT	12	1.30 LBS	
11	GUB-4352	1/2" X 3" X 5-1/4" GALV U-BOLT	18	0.71 LBS	
12	GB-04145	1/2" X 1-1/2" GALV BOLT KIT	6	0.13 LBS	
13	MT546084120	2.88" OD X 84" LONG PIPE	6	24.81 LBS	
14	MT546120120	PIPE, 2.875"OD X 120"	12	35.44 LBS	
15	MT546180276	PIPE, 2.875"OD X 180"	6	115.33 LBS	
16	SFG2255	LABEL, SFG22HDX	3	0.04 LBS	

COMMSCOPE, INC. OF NORTH CAROLINA			
TITLE MP, 15' SF KIT OF 3 W/COLLAR, AP			
SIZE <b>C</b>	SCALE <b>1:20</b>	DOCUMENT NO. <b>MCG22HDX15-12-H10</b>	
DRAWING		VERSION	STATUS
REVISION		00	RE
SHEET		2 OF 4	

4

3

2

1

**ALLOWABLE TIEBACK ANGLE**

±15 DEGREES VERTICAL  
±25 DEGREES HORIZONTAL

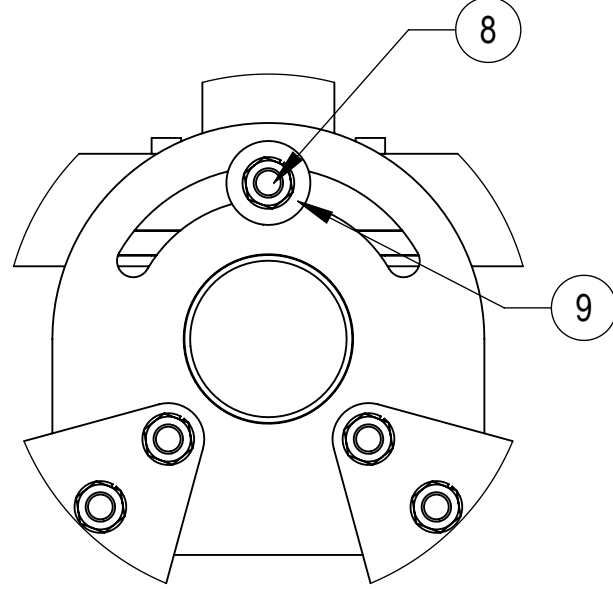
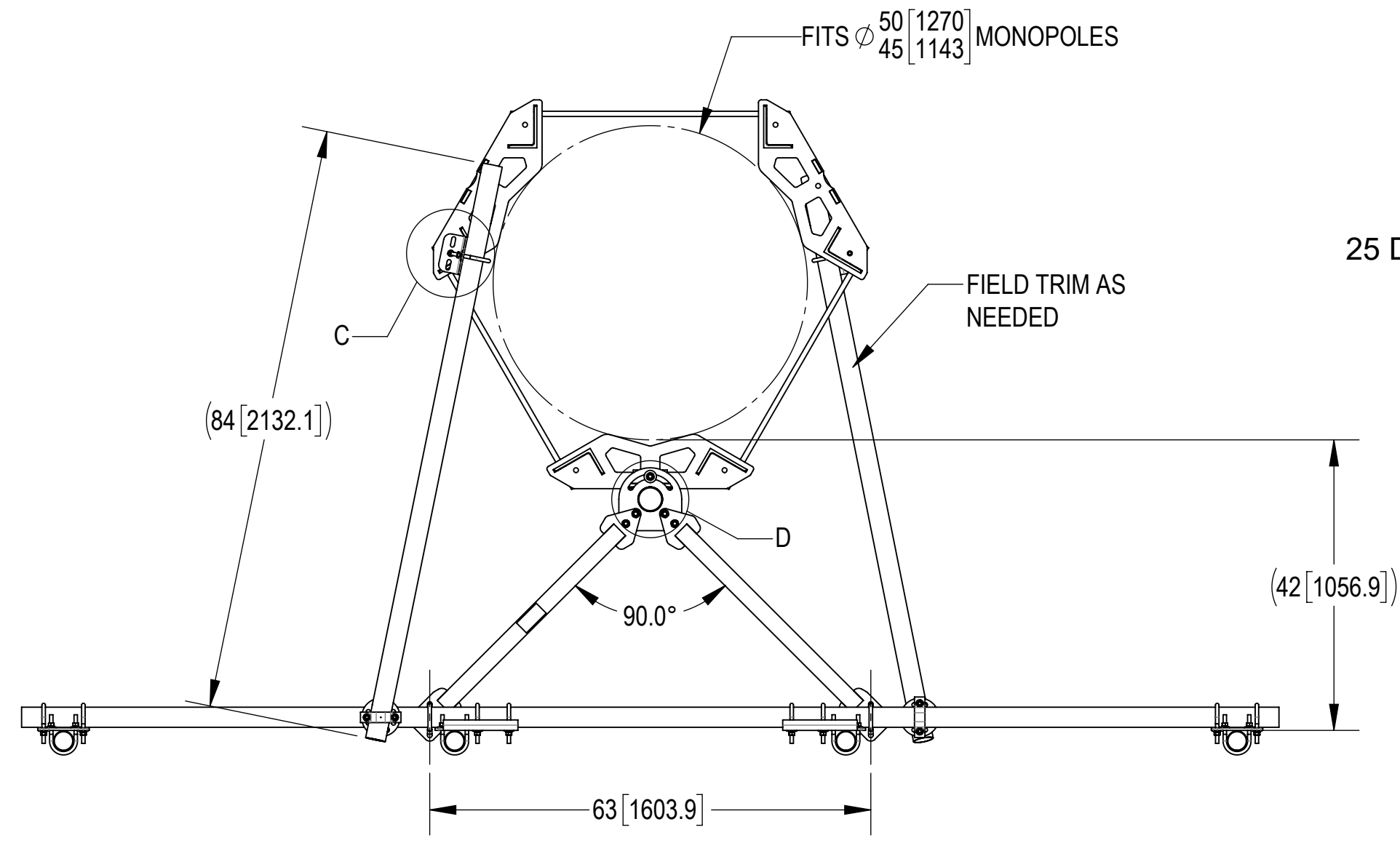
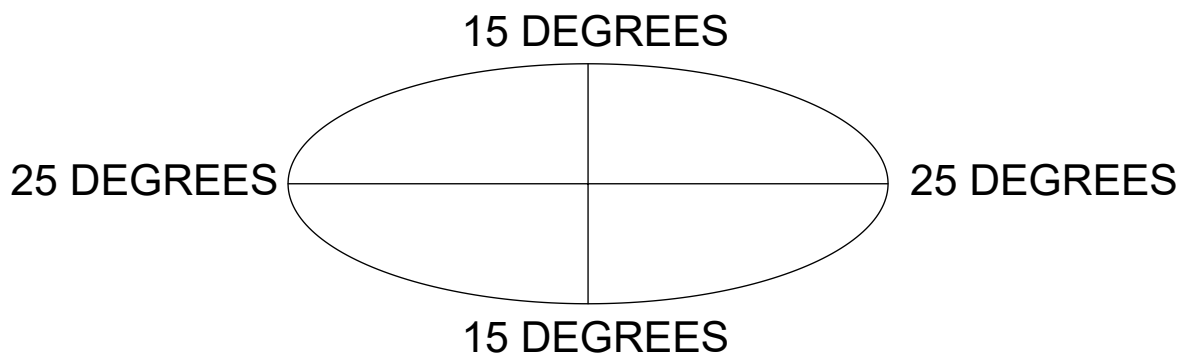

DETAIL D  
SCALE 1:4

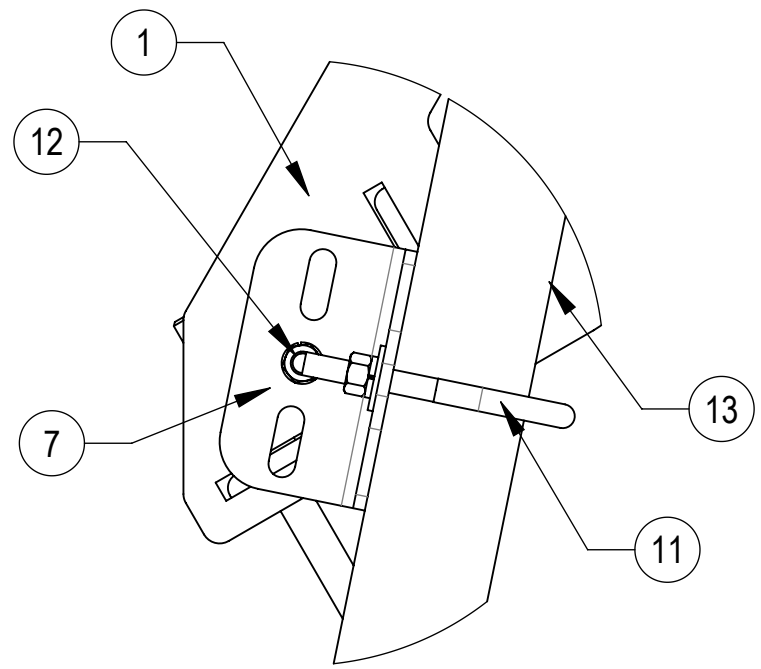

DETAIL C  
SCALE 1:4

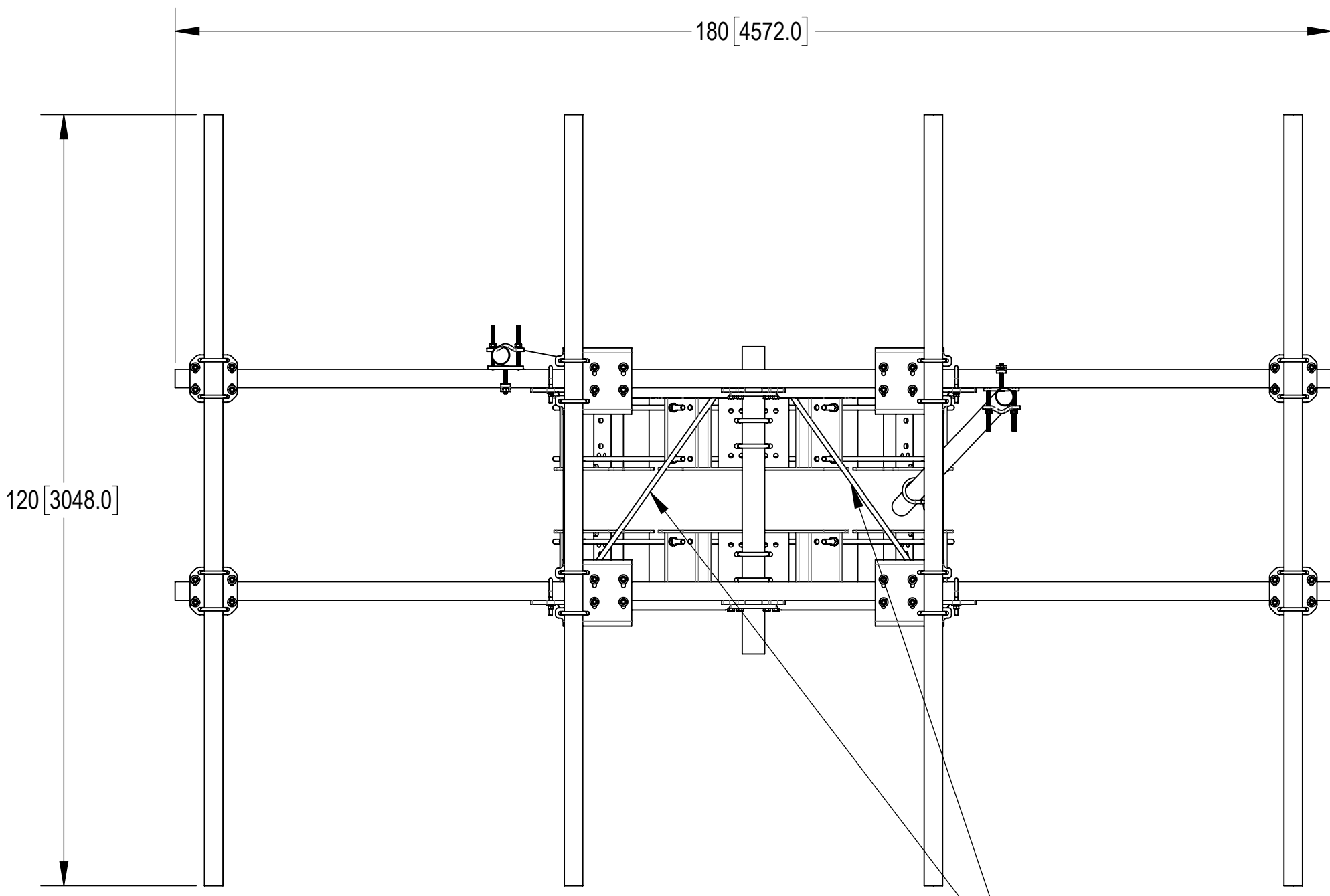

TOP  
BOTTOM

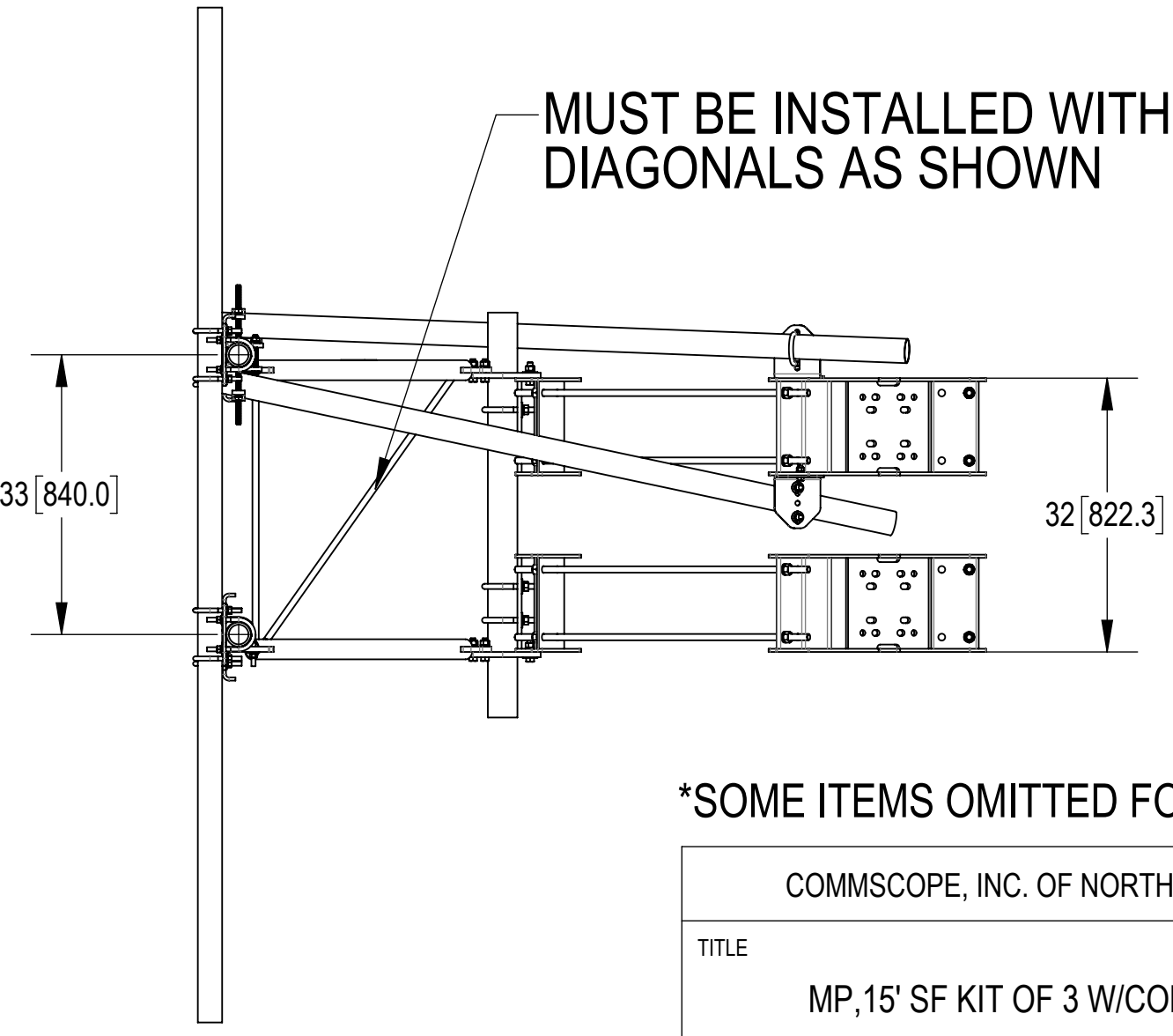

MUST BE INSTALLED WITH DIAGONALS AS SHOWN

\*SOME ITEMS OMITTED FOR CLARITY\*

COMMSCOPE, INC. OF NORTH CAROLINA				
TITLE MP, 15' SF KIT OF 3 W/COLLAR, AP				
SIZE C	SCALE 1:20	DOCUMENT NO. MCG22HDX15-12-H10		
		DRAWING		SHEET
		VERSION	STATUS	REVISION
		00	RE	A
				3 OF 4

4

3



2

1

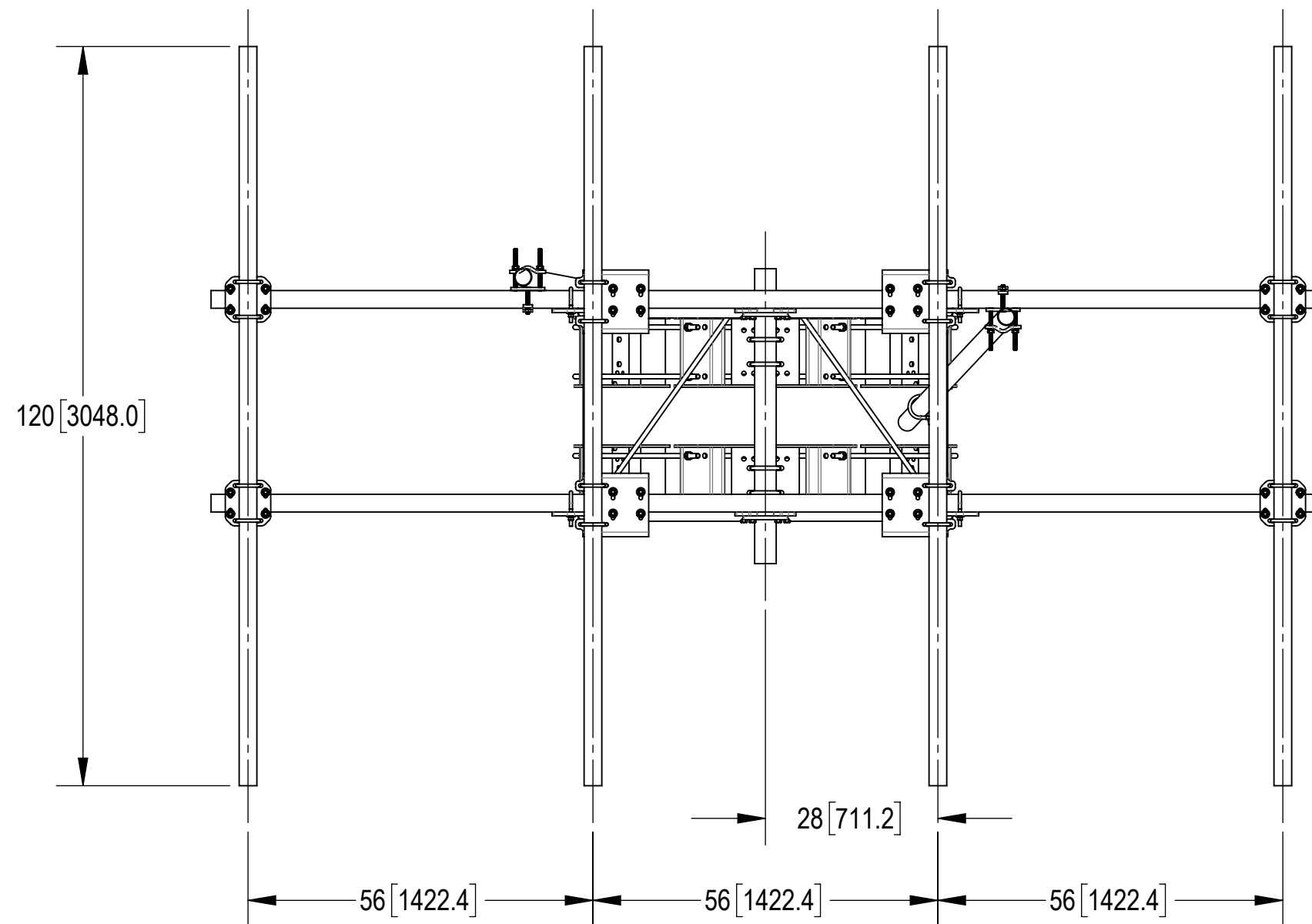
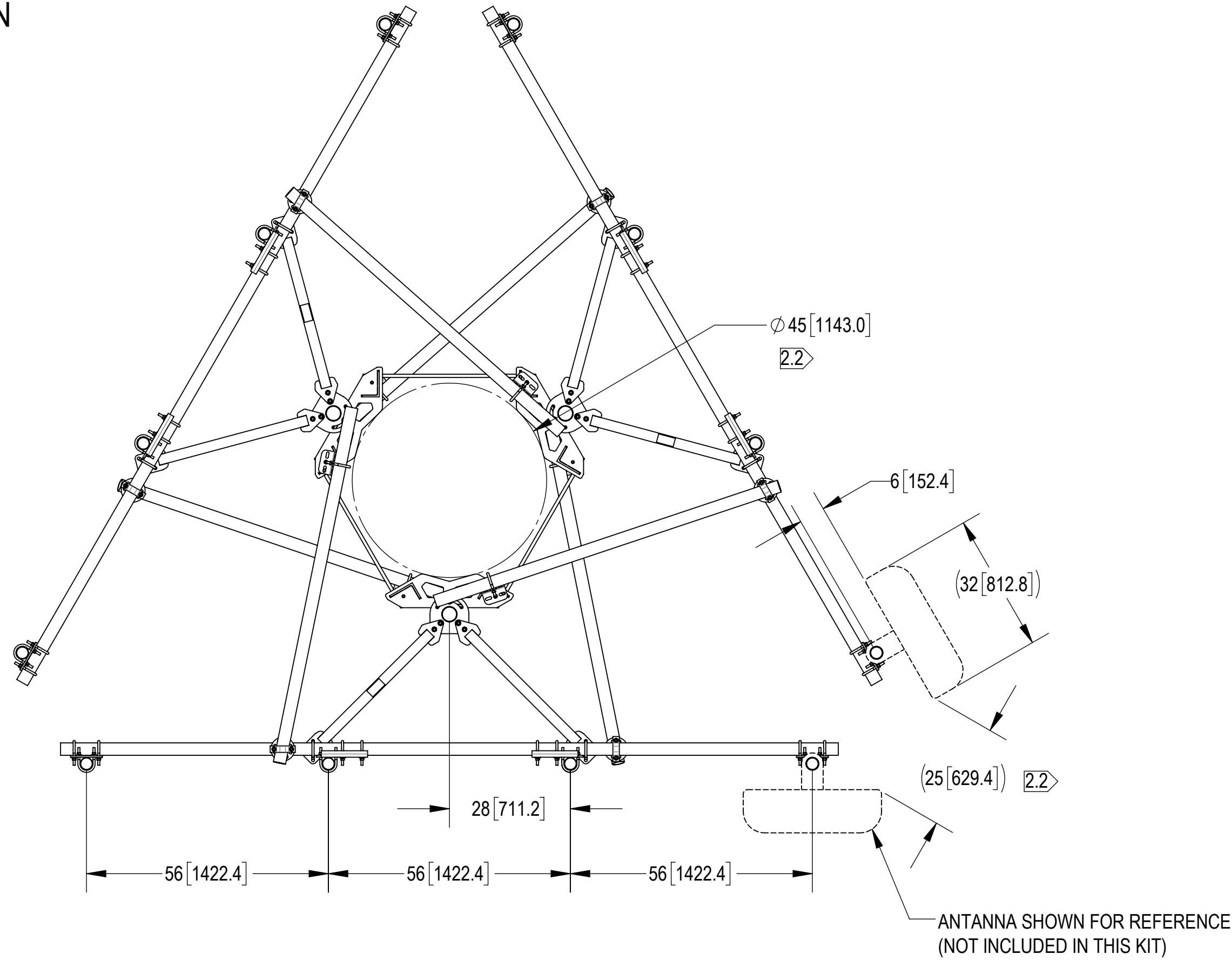
ANTENNA SPACING SHOWN



\*SOME ITEMS OMITTED FOR CLARITY\*

COMMSCOPE, INC. OF NORTH CAROLINA				
TITLE MP, 15' SF KIT OF 3 W/COLLAR, AP				
SIZE C	SCALE 1:24	DOCUMENT NO. MCG22HDX15-12-H10		
DRAWING		VERSION	STATUS	REVISION
 		00	RE	A
				SHEET 4 OF 4