

4

3

2

1

- 1.0 GENERAL NOTES
 - 1.1 ALL METRIC DIMENSIONS ARE IN BRACKETS [X.XX]
 - 1.2 FOR PATENT INFO: <https://www.cs-pat.com>
- 2.0 DESIGN NOTES
 - 2.1 ANY HAZARDS OR OBSTRUCTIONS TO THE CLIMBING FACILITY AND SAFETY CLIMB MUST BE IDENTIFIED PRIOR TO INSTALLING THE APPURTENANCE. ADDITIONAL PRODUCTS MAY BE REQUIRED TO MAINTAIN THE INTEGRITY OF THE SAFETY CLIMB. DURING INSTALLATION, TEMPORARY AND/OR PERMANENT PRECAUTIONARY MEASURES SHOULD BE TAKEN TO PRESERVE THE CLIMBING FACILITY AND/OR SAFETY CLIMB.
 - 2.2 UP TO 5.0° TAPER AVAILABLE ON MODELS THAT SUPPORT ADJUSTMENT.
- 3.0 MANUFACTURING/SPECIAL REQUIREMENTS
 - 3.1 TIGHTEN ALL BOLTS SECURING FLAT PLATES BY THE TURN-OF-NUT METHOD. TIGHTEN ALL U-BOLTS USING TURN-OF-NUT METHOD WITH ATTENTION TO LEAVE EQUAL DISTANCE AND EQUAL FORCE ON EACH LEG OF THE U-BOLT.
- 4.0 TEST
- 5.0 PACKAGING
 - 5.1 PACKAGING SHALL MEET COMMSCOPE REQUIREMENTS PER DOCUMENT IS-PL-3005.
 - 5.2 PRINTED DOCUMENT TO BE PLACED INSIDE POLYBAG AND THEN IN SHIPPING CONTAINER.
 - 5.3 EXTRA HARDWARE MAY BE SUPPLIED, BAGGED AND SHIPPED.

REVISIONS			
REV.	DESCRIPTION	DATE	APPROVED
A	INITIAL RELEASE	JL1183 05FEB24	CB1094 40188553CMO
B	SADDLE MOUNT CHANGED TO G23	YMENG 13JUN24	BA1025 40197994CMO

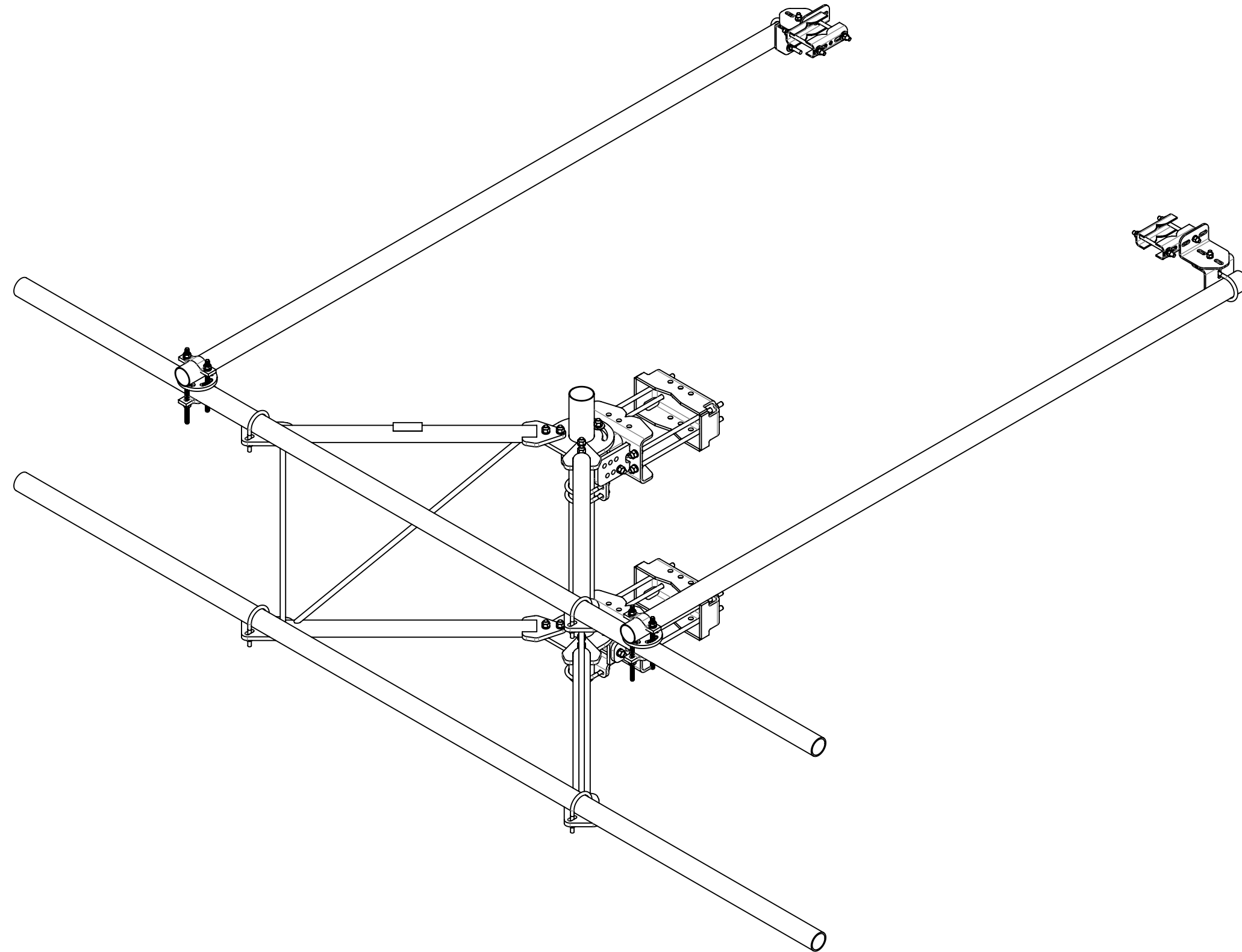

COMMSCOPE, INC. OF NORTH CAROLINA												
TOLERANCES						SAP MATERIAL MASTER						
0 PLACE .X[X] ± 0.25[6.3]			2 PLACE .XX[X] ± 0.06[1.5]			SFG22HDX-13-B						
1 PLACE .X[X] ± 0.12[3.0]			ANGLES ± 2°									
FINISH						MATERIAL						
UNLESS OTHERWISE SPECIFIED DIMENSIONS ARE IN INCHES INTERPRET PER ANSI Y 14.5M-1994			NAME		DATE		TITLE					
			CE JL1183		05FEB24		PIM-GUARD-SF, 13'FACE, NO-AP					
			RW YMENG		06/18/2024							
			AD BA1025		06/21/2024							
			RE YMENG		06/27/2024							
ECN 40197994CMO						SCALE		DOCUMENT NO.				
						1:16		SFG22HDX-13-B				
SIZE		Auth Group		INSL		MODEL			DRAWING			SHEET 1 OF 6
C						VERSION	STATUS	REVISION	VERSION	STATUS	REVISION	
						01	RE	B	01	RE	B	

DENSITY		lbs/in³
MASS	499.31	lbs
VOLUME	1764.54	in³
SURFACE AREA	17638.30	in²
HEIGHT	47.88"	
LENGTH	156"	
WIDTH	120"	

4

3

2

1

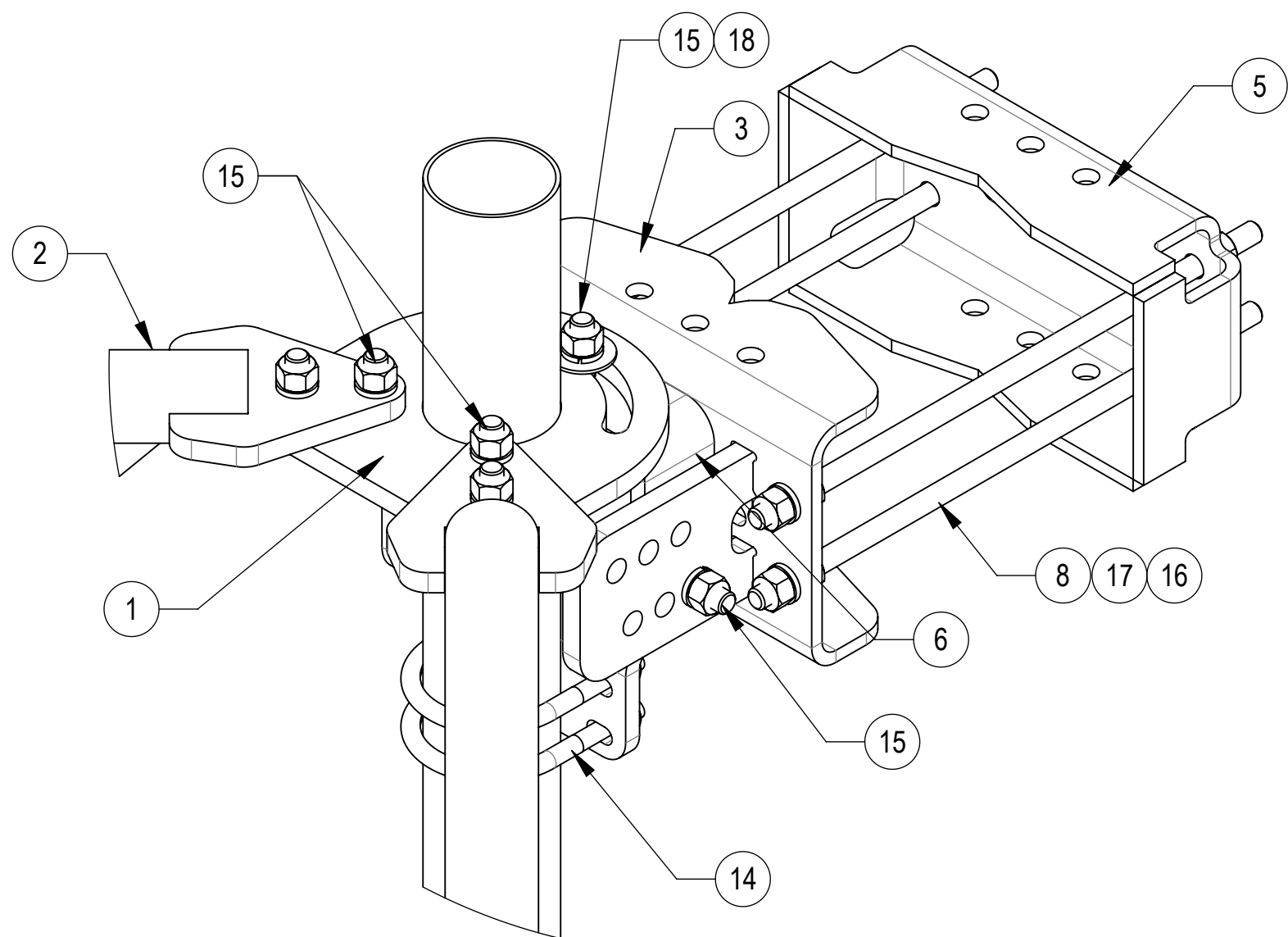

DETAIL B
SCALE 1 : 4

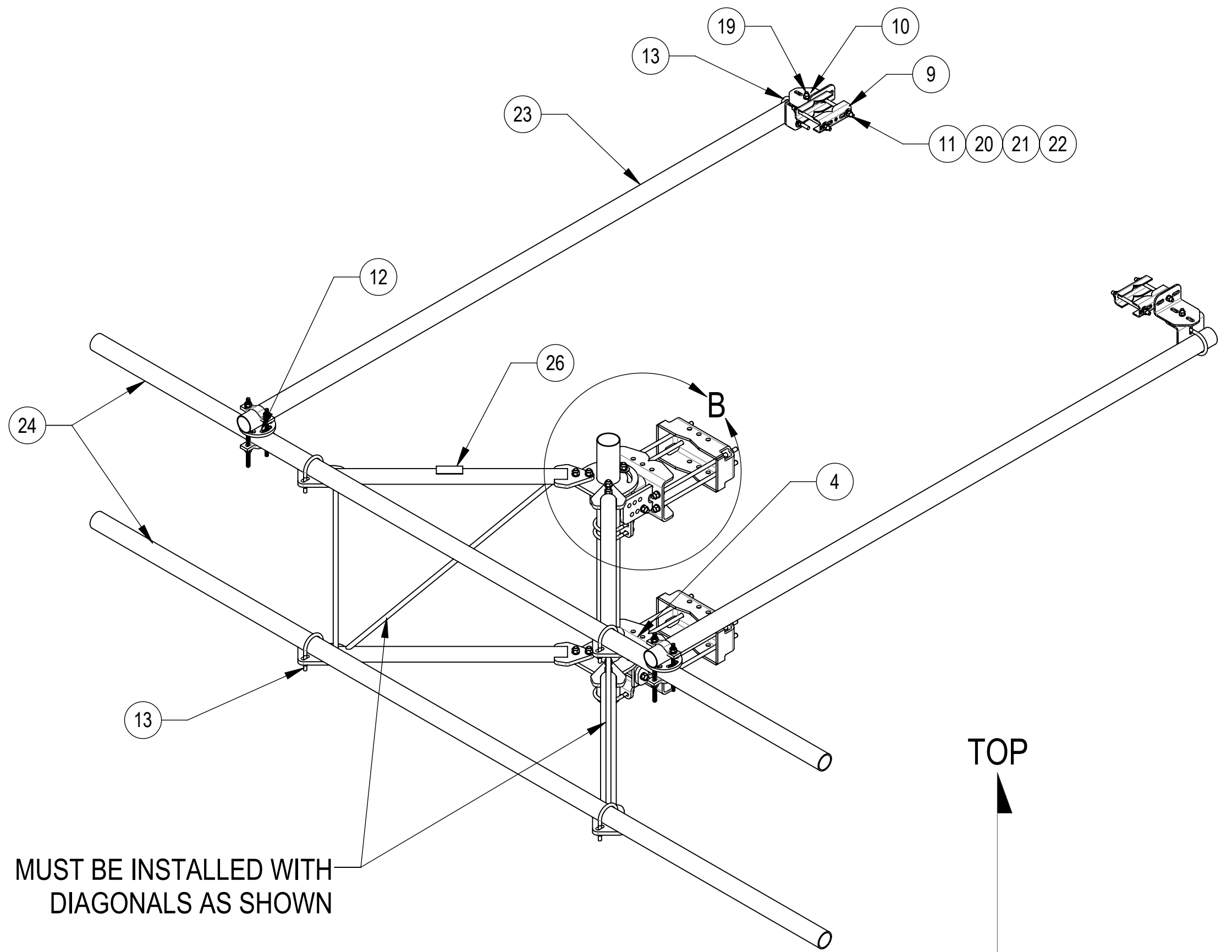

**MUST BE INSTALLED WITH
DIAGONALS AS SHOWN**

ALLOWABLE TIEBACK ANGLE

± 15 DEGREES VERTICAL
± 25 DEGREES HORIZONTAL

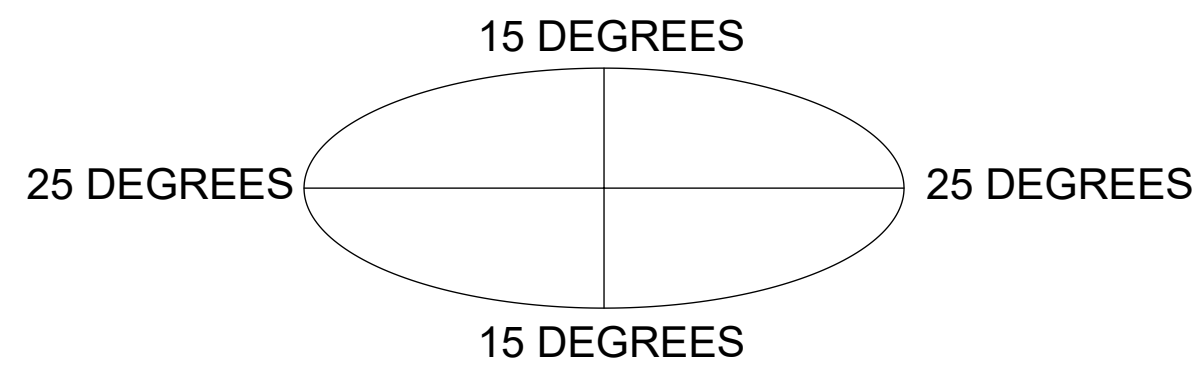

COMPONENT PART NUMBERS PROVIDED FOR ASSEMBLY PURPOSES;
INDIVIDUAL COMPONENTS MAY BE SHIPPED AS PARTS WITHIN AN INCLUDED KIT.

ITEM	PART NO.	DESCRIPTION	QTY.	WEIGHT	NOTE
1	SFG2270	BACK VERTICAL ARM MOUNT	1	36.96 LBS	
2	SFG2278	ARM, STANDOFF - SFG22	2	40.92 LBS	
3	SFG2380	WELDMENT, HD, TOP TAPER BRACKET	1	22.78 LBS	
4	SFG2381	WELDMENT, HD, LOWER TOWER LEG BRACKET	1	17.42 LBS	
5	SFG2289	G2 RRU BACK CLAMP, HD	2	18.65 LBS	
6	SFG2386	WELDMENT, SFG2 AZIMUTH BRACKET	1	10.07 LBS	
7	SFG2397-00	WELDMENT, G23 AZIMUTH BRACKET	1	7.94 LBS	
8	MT-382-18	5/8" X 18" THREADED ROD	8	1.43 LBS	
9	SAB01	FORMED CLAMP	4	1.35 LBS	
10	XAU01	ANGLE, CROSSOVER, 1.9-3.5" X 1.9-3.5" OD	4	2.98 LBS	
11	MT-379-8	1/2" X 8" GALV THREADED ROD	4	0.45 LBS	
12	XP-R	CROSSOVER PLATE, ROUND, UP TO 3.5" OD	2	6.20 LBS	
13	GUB-4352	1/2" X 3" X 5-1/4" GALV U-BOLT	6	0.71 LBS	
14	GUB-4355	1/2" X 3-5/8" X 5" GALV U-BOLT	3	0.71 LBS	
15	GB-05225	5/8" X 2-1/4" GALV BOLT KIT	14	0.28 LBS	
16	GN-05	5/8" GALV HEX NUT	24	0.08 LBS	
17	GWL-05	5/8" GALV LOCK WASHER	16	0.03 LBS	
18	GWF-05	5/8" GALV FLAT WASHER, 1.7OD	2	0.06 LBS	
19	GB-04145	1/2" X 1-1/2" GALV BOLT KIT	2	0.13 LBS	
20	GN-04	1/2" GALV HEX NUT	10	0.04 LBS	
21	GWL-04	1/2" GALV LOCK WASHER	10	0.01 LBS	
22	GWF-04	1/2" GALV FLAT WASHER	8	0.04 LBS	
23	MT546120120	PIPE, 2.875"OD X 120"	2	35.44 LBS	
24	MT546156	2.875" O.D. X 156" PIPE	2	75.58 LBS	
25	GUB-53560	5/8" X 3-5/8" X 6" GALV U-BOLT	4	1.30 LBS	FOR RING MOUNT ONLY
26	SFG2255	LABEL, SFG22HDX	1	0.04 LBS	

COMMSCOPE, INC. OF NORTH CAROLINA				
TITLE PIM-GUARD-SF,13'FACE,NO-AP				
SIZE C	SCALE 1:16	DOCUMENT NO. SFG22HDX-13-B		
DRAWING		VERSION	STATUS	REVISION
		01	RE	B
				SHEET 2 OF 6

4

3

2

1

TIEBACK MUST BE CONNECTED TO A RIGID MEMBER THAT PROVIDES ADEQUATE SUPPORT WITHIN THE LIMITS NOTED IN THE TIEBACK ANGLE RANGE DETAIL. UNLESS APPROVED BY ENGINEER OF RECORD. SPINE STEM OF NEIGHBORING MOUNT IS ACCEPTABLE.

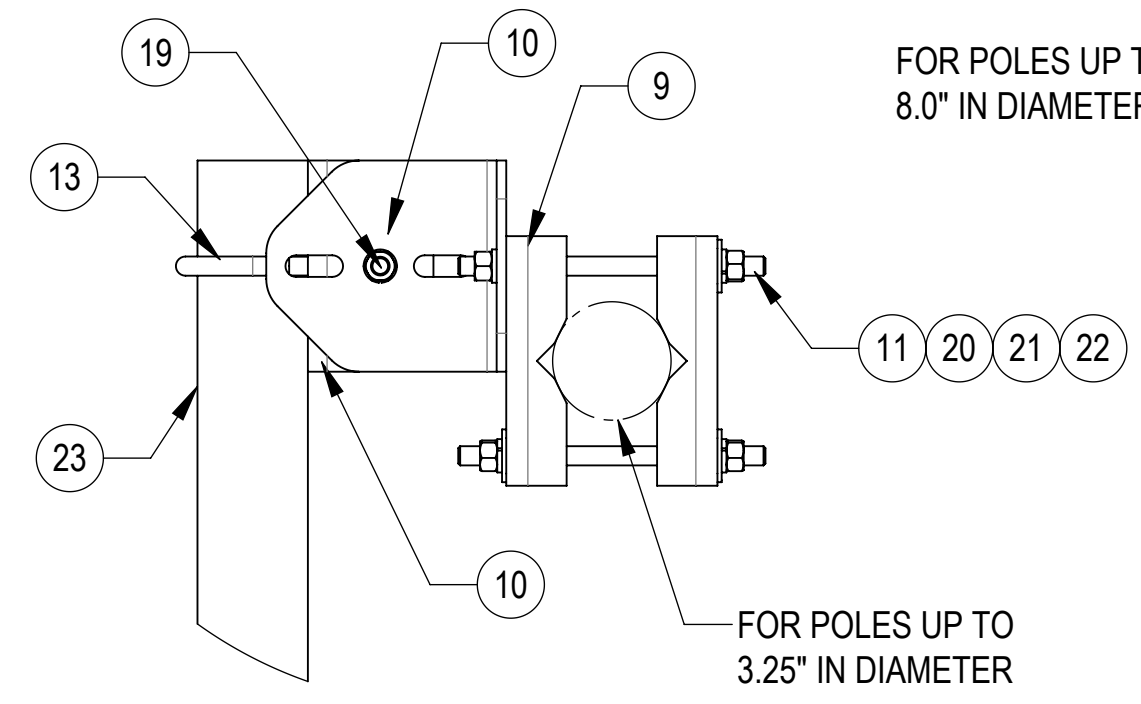
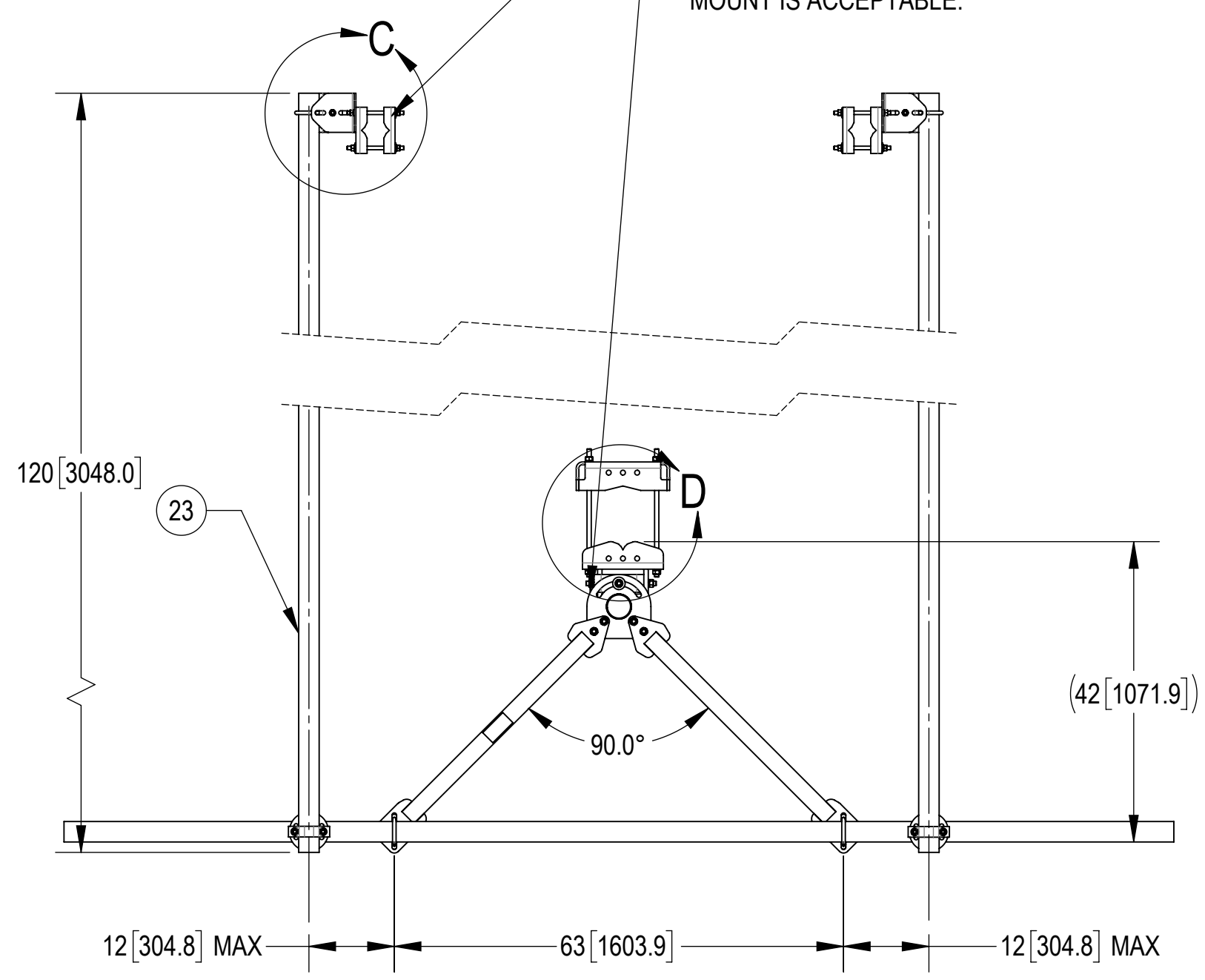

DETAIL C
SCALE 1 : 5

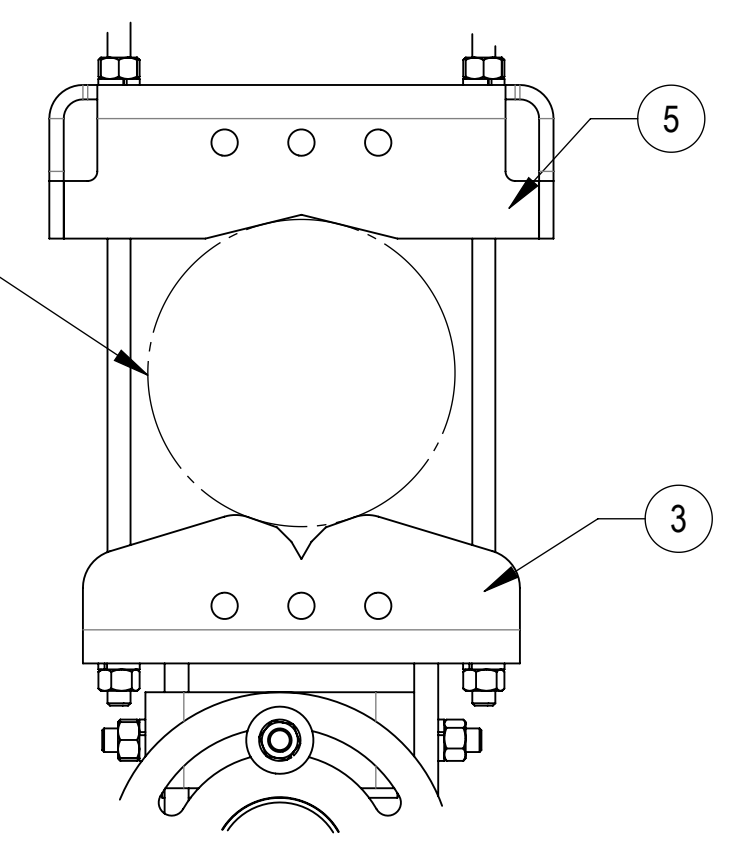

DETAIL D
SCALE 1 : 5

ALLOWABLE TIEBACK ANGLE
 ±15 DEGREES VERTICAL
 ±25 DEGREES HORIZONTAL

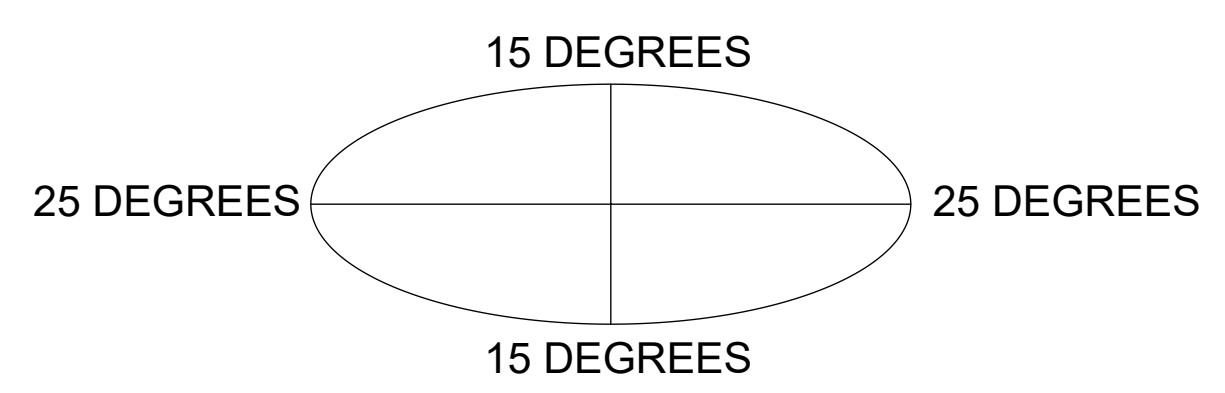

TOP
 BOTTOM

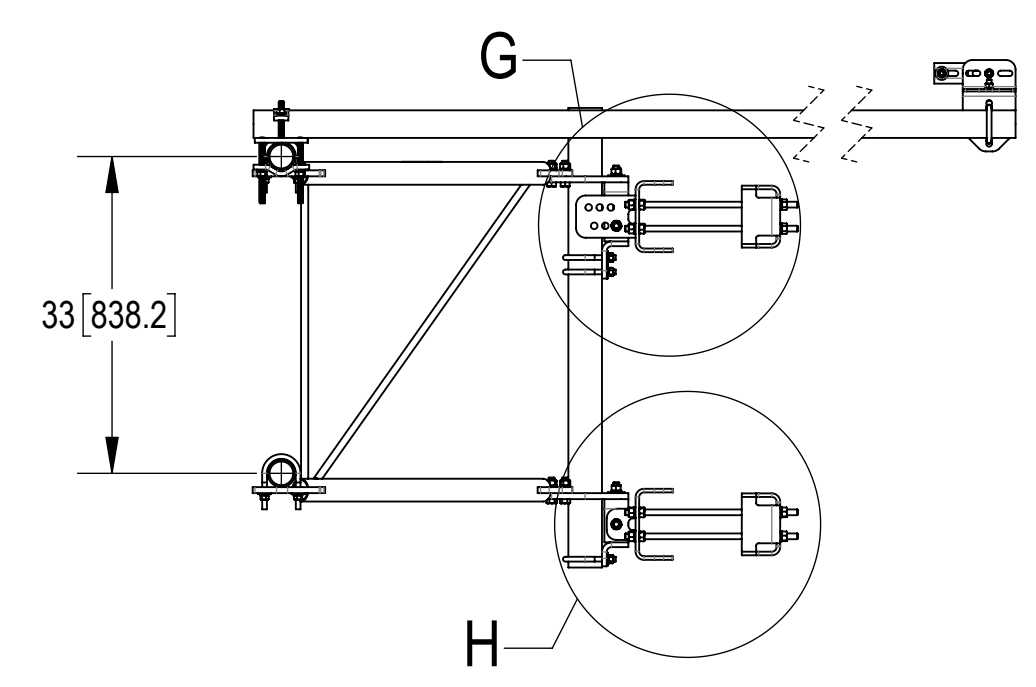
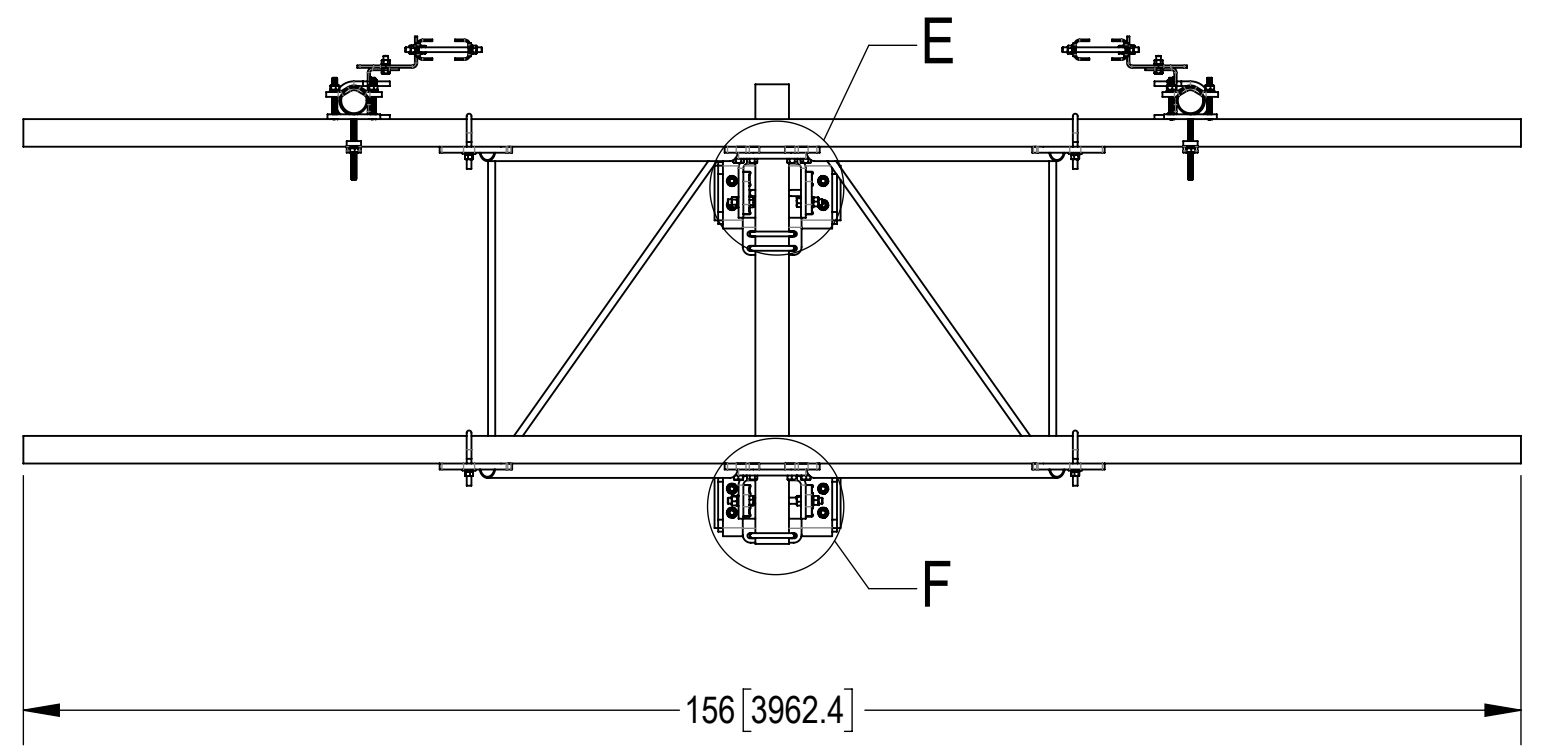

COMMSCOPE, INC. OF NORTH CAROLINA				
TITLE PIM-GUARD-SF,13'FACE,NO-AP				
SIZE C	SCALE 1:20	DOCUMENT NO. SFG22HDX-13-B		
		DRAWING		SHEET
		VERSION	STATUS	REVISION
		01	RE	B
				SHEET 3 OF 6

4

3

2

1

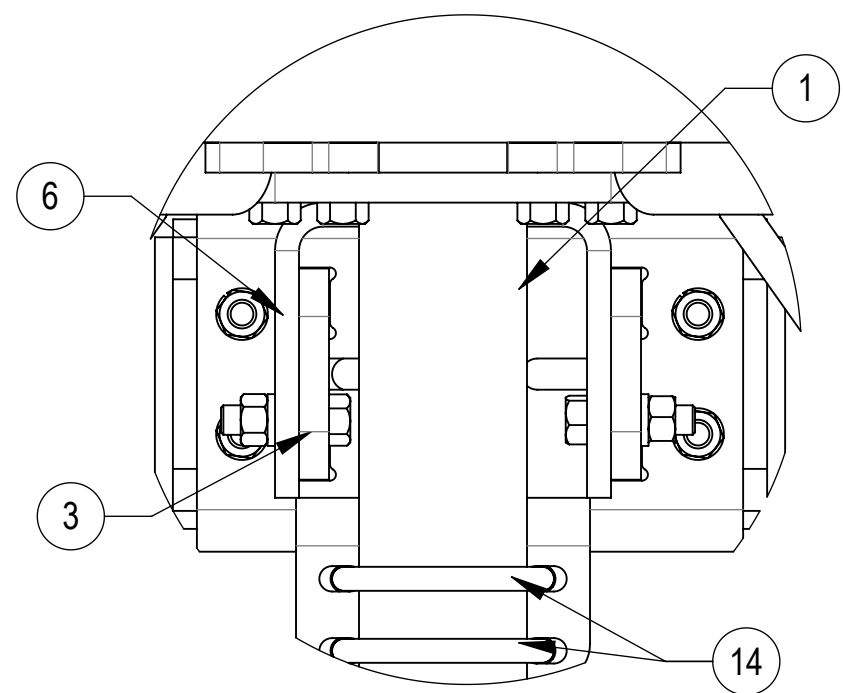

DETAIL E
SCALE 1 : 4

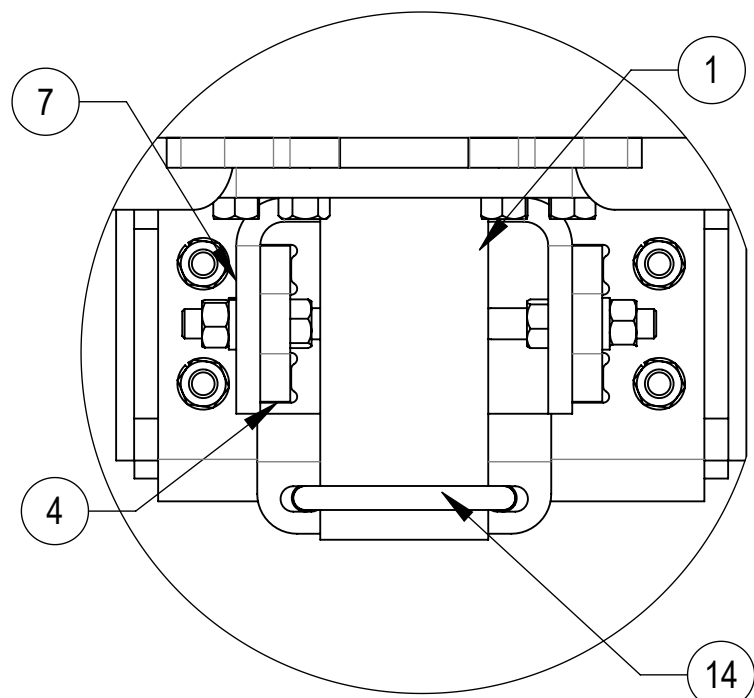

DETAIL F
SCALE 1 : 4

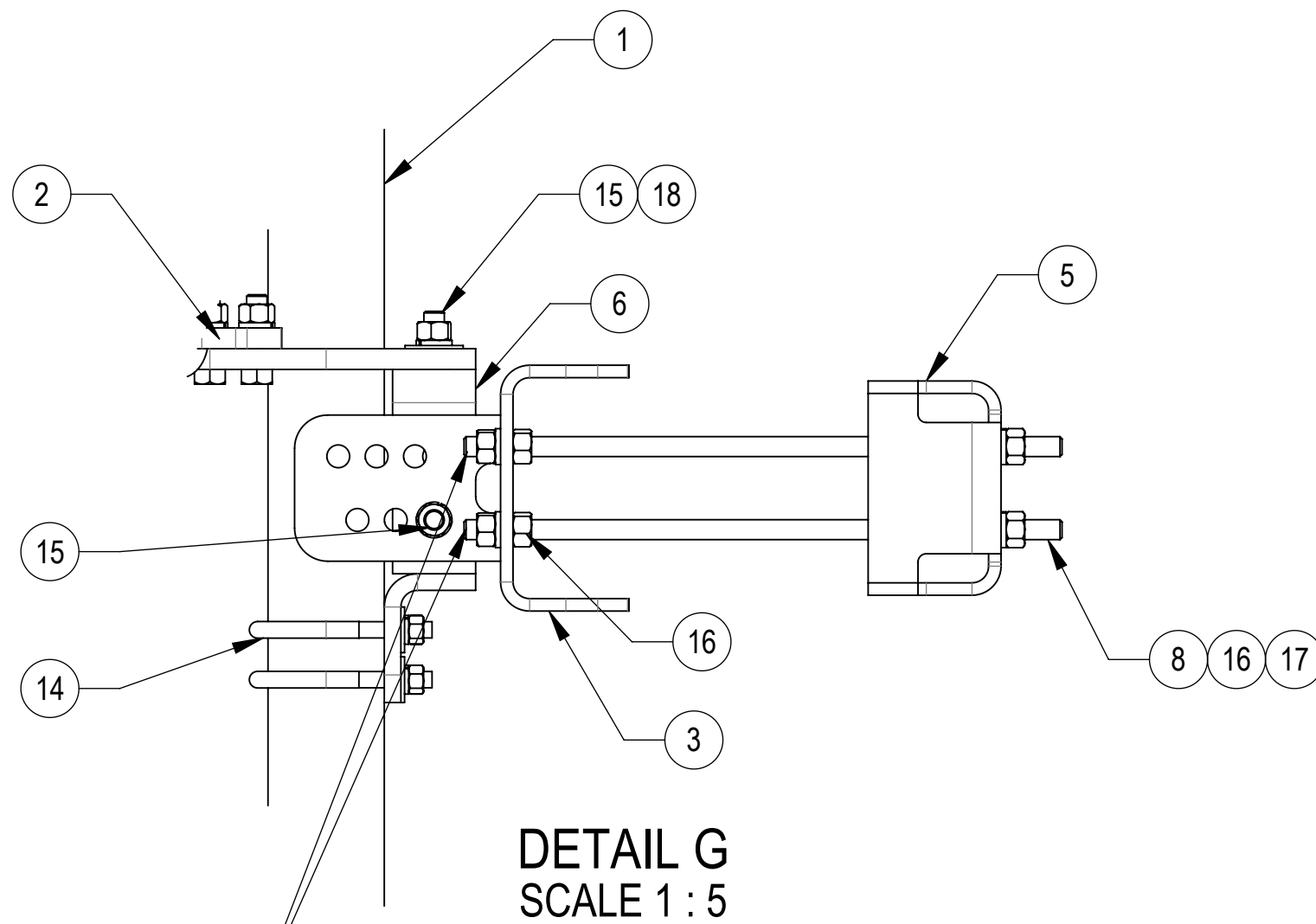

DETAIL G
SCALE 1 : 5

THE THREADED ROD CAN ONLY EXPOSE 4 TO 7 THREADS ON ONE SIDE OF THE BRACKET, WHICH IS TO PREVENT INTERFERENCE WITH THE SIDE BOLTS

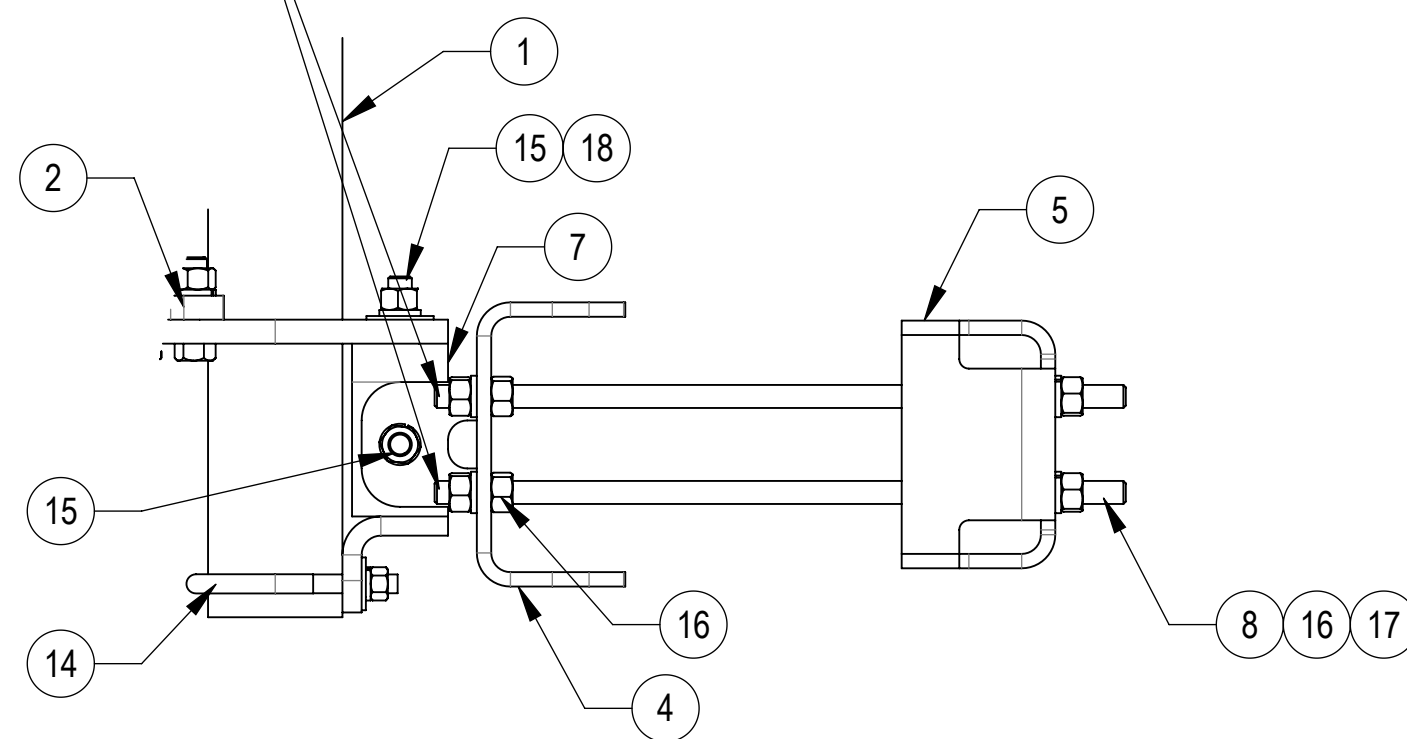

DETAIL H
SCALE 1 : 5

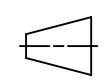
COMMSCOPE, INC. OF NORTH CAROLINA					
TITLE PIM-GUARD-SF,13'FACE,NO-AP					
SIZE C	SCALE 1:6	DOCUMENT NO. SFG22HDX-13-B			
 		DRAWING			SHEET 4 OF 6
		VERSION 01	STATUS RE	REVISION B	

4

3

2

1

OPTIONAL ACCESSORIES:

RING MOUNT KIT FOR MONOPOLE INSTALLATION (SOLD SEPERATELY)

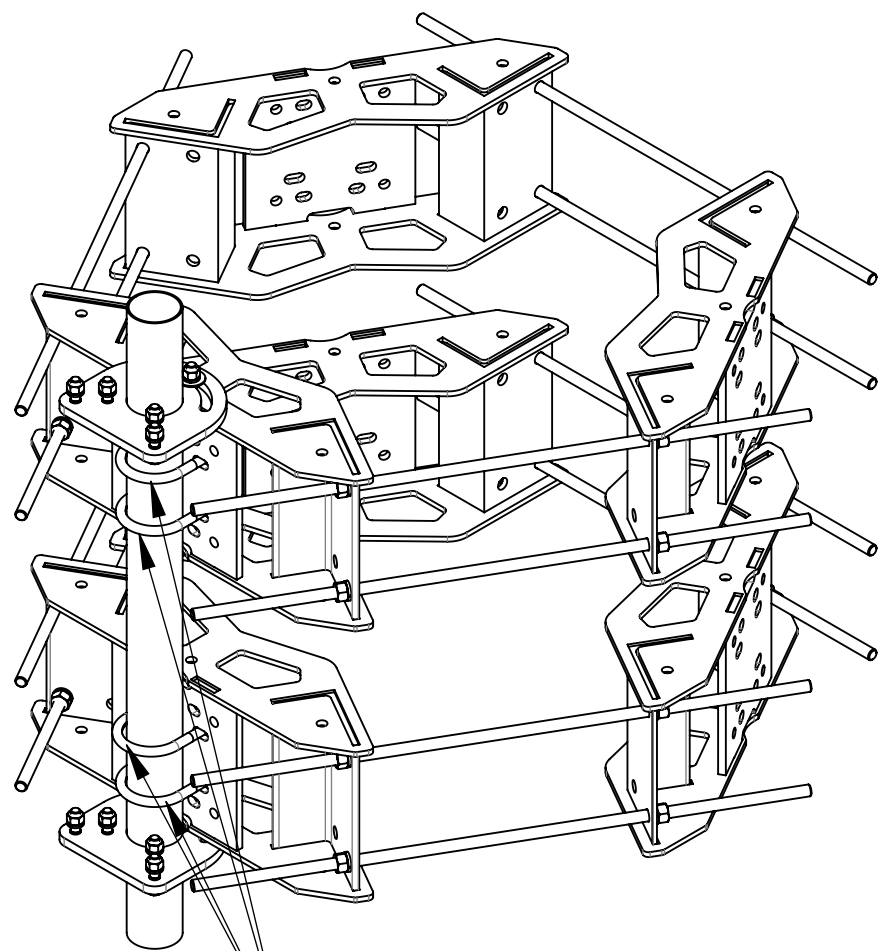

25 GUB-53560 (USE ON MONOPOLE VERSION ONLY)

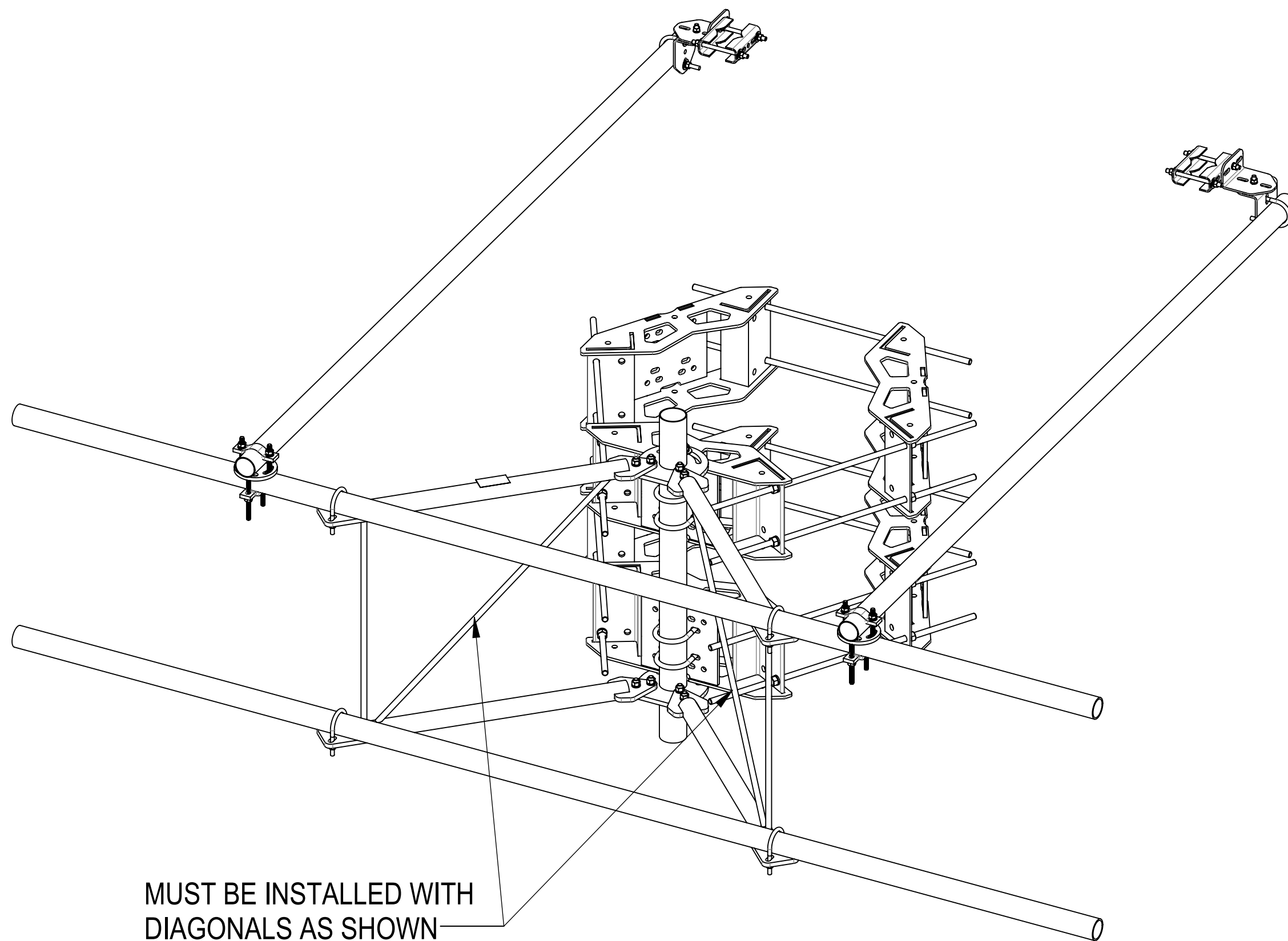

ALLOWABLE TIEBACK ANGLE

±15 DEGREES VERTICAL
±25 DEGREES HORIZONTAL

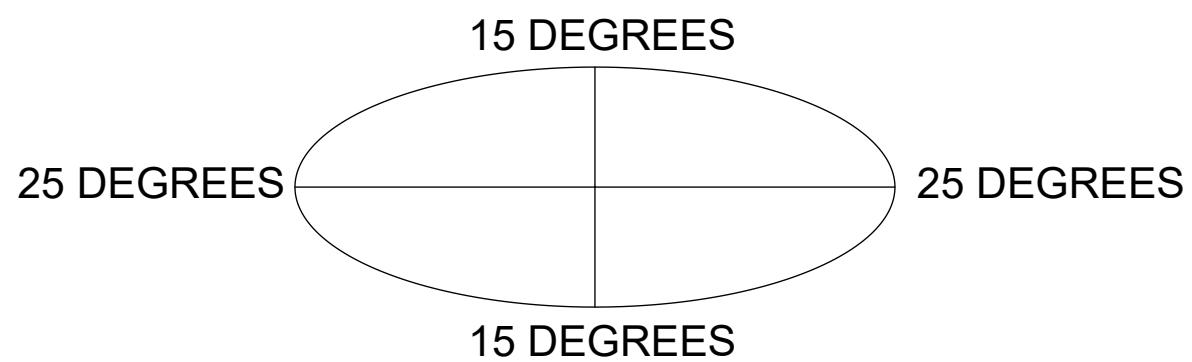

COMMSCOPE, INC. OF NORTH CAROLINA

TITLE
PIM-GUARD-SF,13'FACE,NO-AP

SIZE C	SCALE 1:14	DOCUMENT NO. SFG22HDX-13-B
------------------	----------------------	--------------------------------------

DRAWING	SHEET	
	VERSION	REVISION
01	RE	B
5 OF 6		

© 2024 CommScope, Inc. Confidential

4

3

2

1

4

3

2

1

OPTIONAL ACCESSORIES:

BUS BAR MOUNT KIT GBSF238 IS WELL SUITED TO BE USED SHOULD THE NEED ARISE
NOTE THAT THIS KIT DOES NOT INCLUDE THE ISOLATORS OR BUS BAR

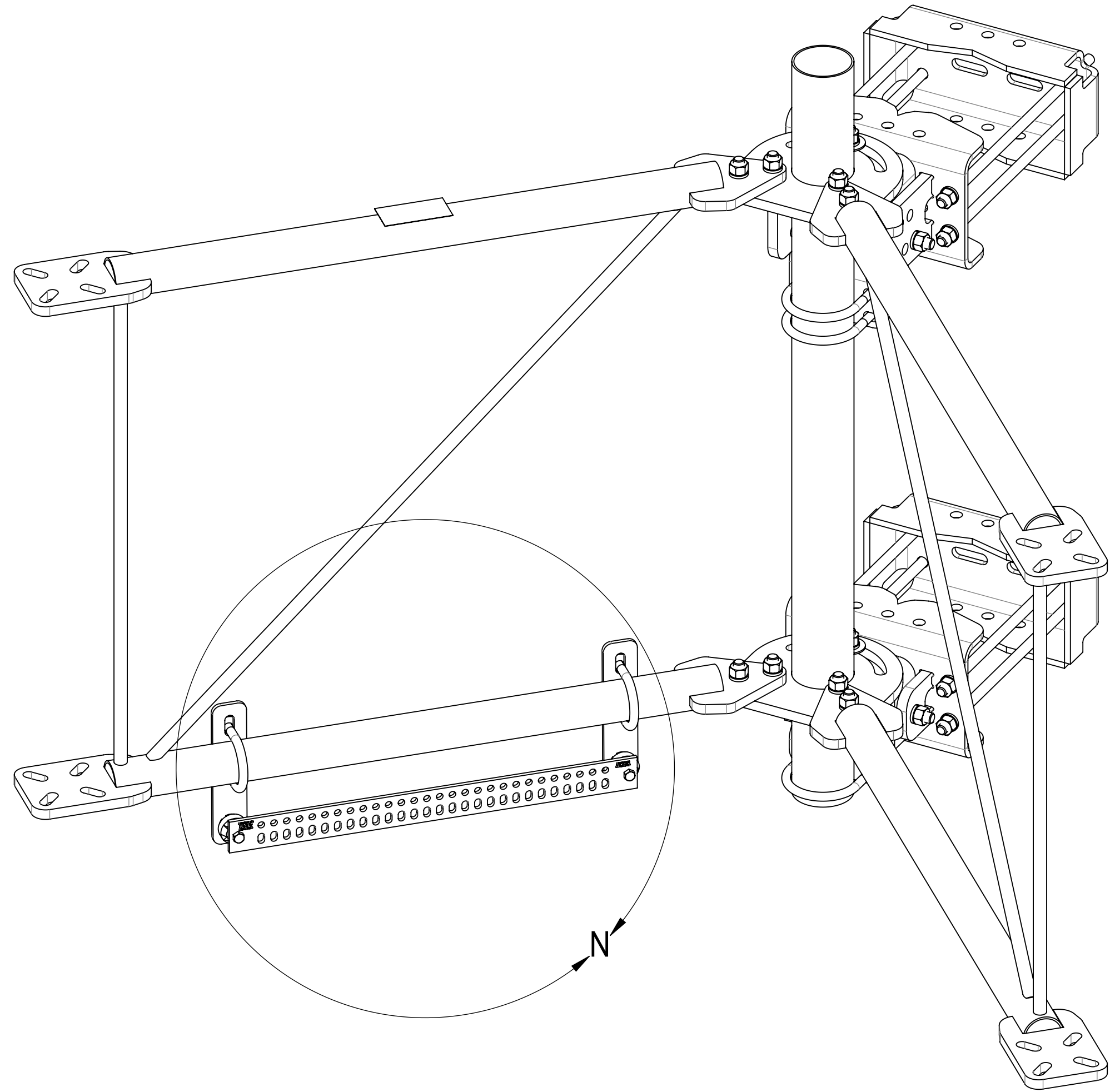
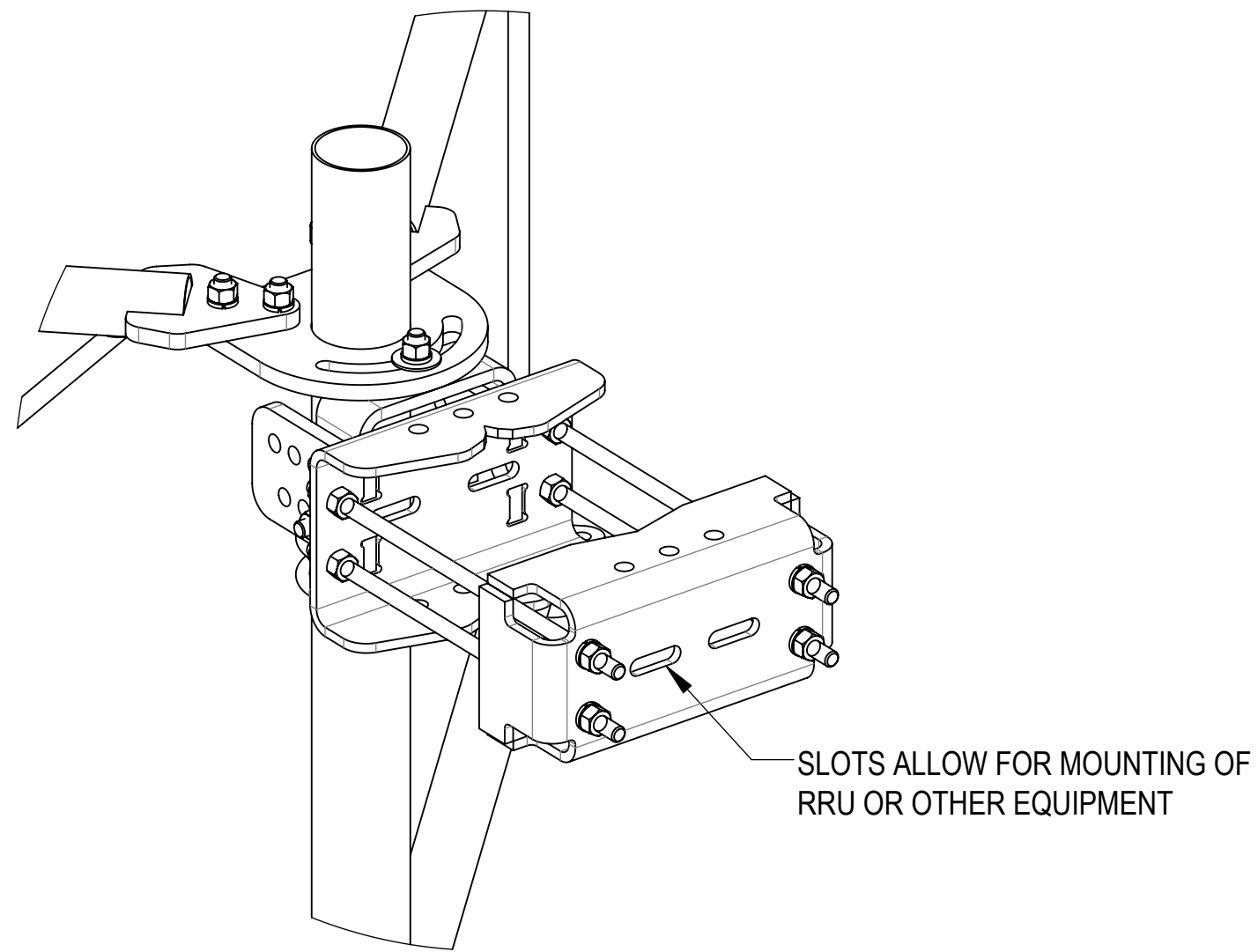

ISO VIEW

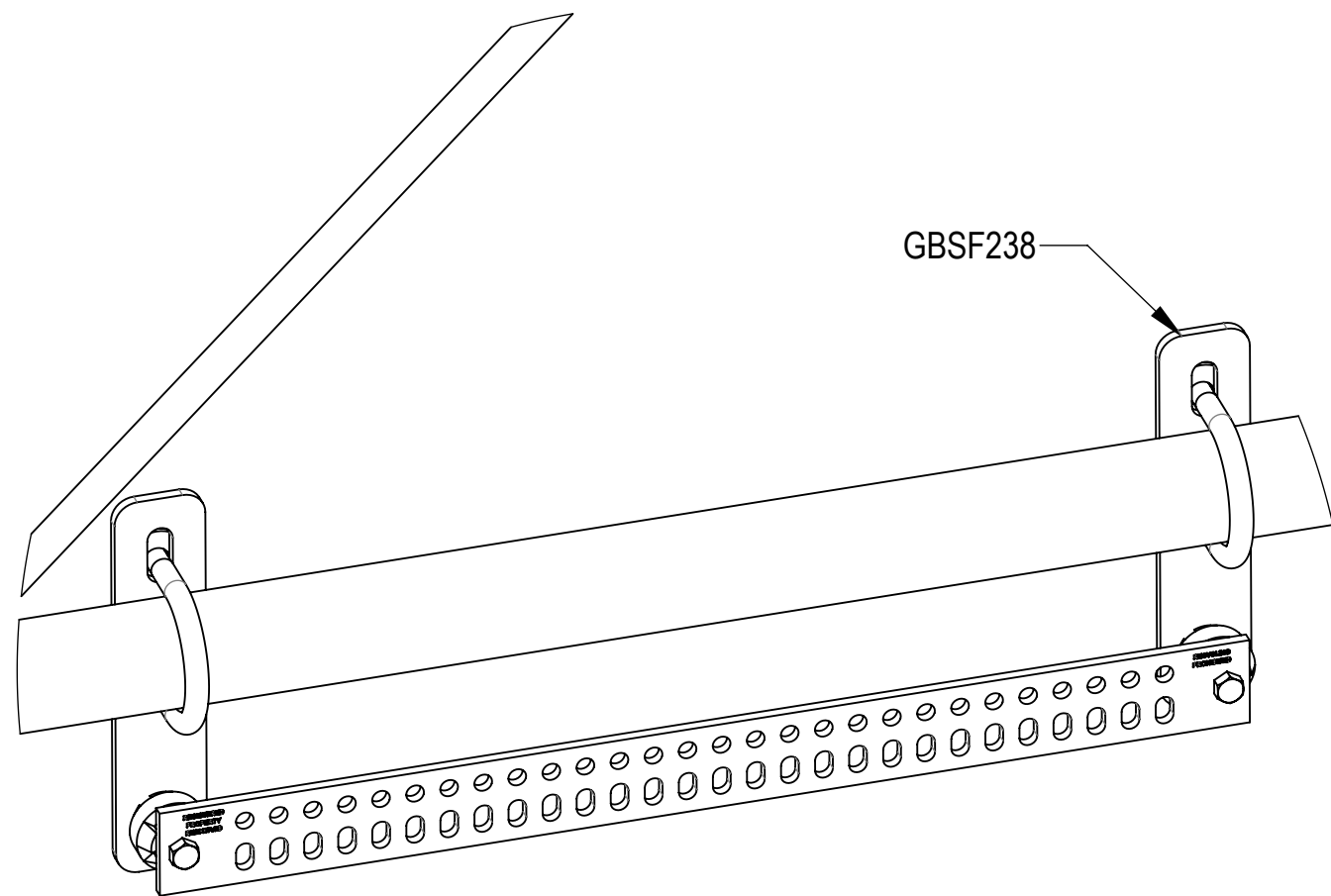

DETAIL N
SCALE 1 : 4

COMMSCOPE, INC. OF NORTH CAROLINA					
TITLE PIM-GUARD-SF,13'FACE,NO-AP					
SIZE C	SCALE 1:6	DOCUMENT NO. SFG22HDX-13-B			
		DRAWING			SHEET 6 OF 6
		VERSION 01	STATUS RE	REVISION B	

4

3

2

1