

4

3

2

1

- 1.0 GENERAL NOTES
 - 1.1 ALL METRIC DIMENSIONS ARE IN BRACKETS [X.X]
 - 1.2 FOR PATENT INFO: <https://www.cs-pat.com>
- 2.0 DESIGN NOTES
 - 2.1 ANY HAZARDS OR OBSTRUCTIONS TO THE CLIMBING FACILITY AND SAFETY CLIMB MUST BE IDENTIFIED PRIOR TO INSTALLING THE APPURTENANCE. ADDITIONAL PRODUCTS MAY BE REQUIRED TO MAINTAIN THE INTEGRITY OF THE SAFETY CLIMB. DURING INSTALLATION, TEMPORARY AND/OR PERMANENT PRECAUTIONARY MEASURES SHOULD BE TAKEN TO PRESERVE THE CLIMBING FACILITY AND/OR SAFETY CLIMB.
 - 2.2 UP TO 5.0° TAPER AVAILABLE ON MODELS THAT SUPPORT ADJUSTMENT
- 3.0 MANUFACTURING/SPECIAL REQUIREMENTS
 - 3.1 TIGHTEN ALL BOLTS SECURING FLAT PLATES BY THE TURN-OF-NUT METHOD. TIGHTEN ALL U-BOLTS USING TURN-OF-NUT METHOD WITH ATTENTION TO LEAVE EQUAL DISTANCE AND EQUAL FORCE ON EACH LEG OF THE U-BOLT.
- 4.0 TEST
- 5.0 PACKAGING
 - 5.1 PACKAGING SHALL MEET COMMSCOPE REQUIREMENTS PER DOCUMENT IS-PL-3005.
 - 5.2 PRINTED DOCUMENT TO BE PLACED INSIDE POLYBAG AND THEN IN SHIPPING CONTAINER.
 - 5.3 EXTRA HARDWARE MAY BE SUPPLIED, BAGGED AND SHIPPED.

REVISIONS			
REV.	DESCRIPTION	DATE	APPROVED
A	INITIAL RELEASE	JL1183 24MAY24	CB1094 40196505CMO
B	UPDATED SFG23175 TO ADD UNIVERSAL INTERFACE PLATES	RY1002 02SEP24	XK1001 40202713CMO

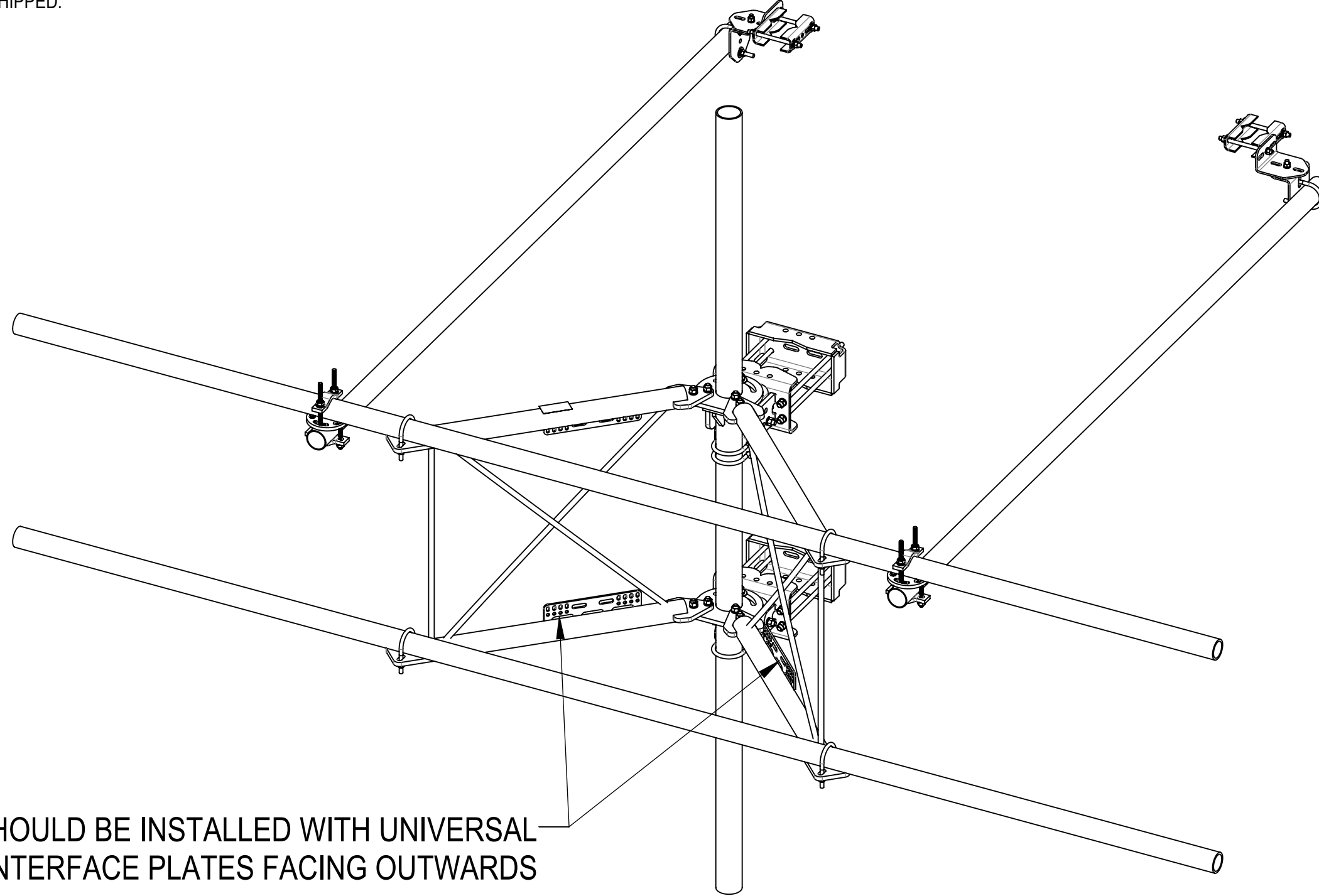

SHOULD BE INSTALLED WITH UNIVERSAL INTERFACE PLATES FACING OUTWARDS

COMMSCOPE, INC. OF NORTH CAROLINA													
TOLERANCES						SAP MATERIAL MASTER							
1 PLACE .X[X] ± 0.2[6.3]			3 PLACE .XXX[X] ± 0.060[1.5]			SFG23RHDX-15-B							
2 PLACE .XX[X] ± 0.12[3.0]			ANGLES ± 2°										
FINISH						MATERIAL							
UNLESS OTHERWISE SPECIFIED DIMENSIONS ARE IN INCHES INTERPRET PER ANSI Y 14.5M-1994				NAME		DATE		SF, 15'FP, NOAP					
				CE JL1183		24MAY24							
				RW RY1002		09/04/2024							
				AD XK1001		09/05/2024							
				RE RY1002		09/14/2024							
ECN 40202713CMO				SCALE		DOCUMENT NO.							
				1:16		SFG23RHDX-15-B							
SIZE		Auth Group		INSL		MODEL			DRAWING			SHEET	
C						VERSION			STATUS			REVISION	
				01			RE			B			1 OF 6

DENSITY		lbs/in³
MASS	688.06	lbs
VOLUME	2427.13	in³
SURFACE AREA	20549.09	in²
HEIGHT	120"	
LENGTH	180"	
WIDTH	120"	

4

3

2

1

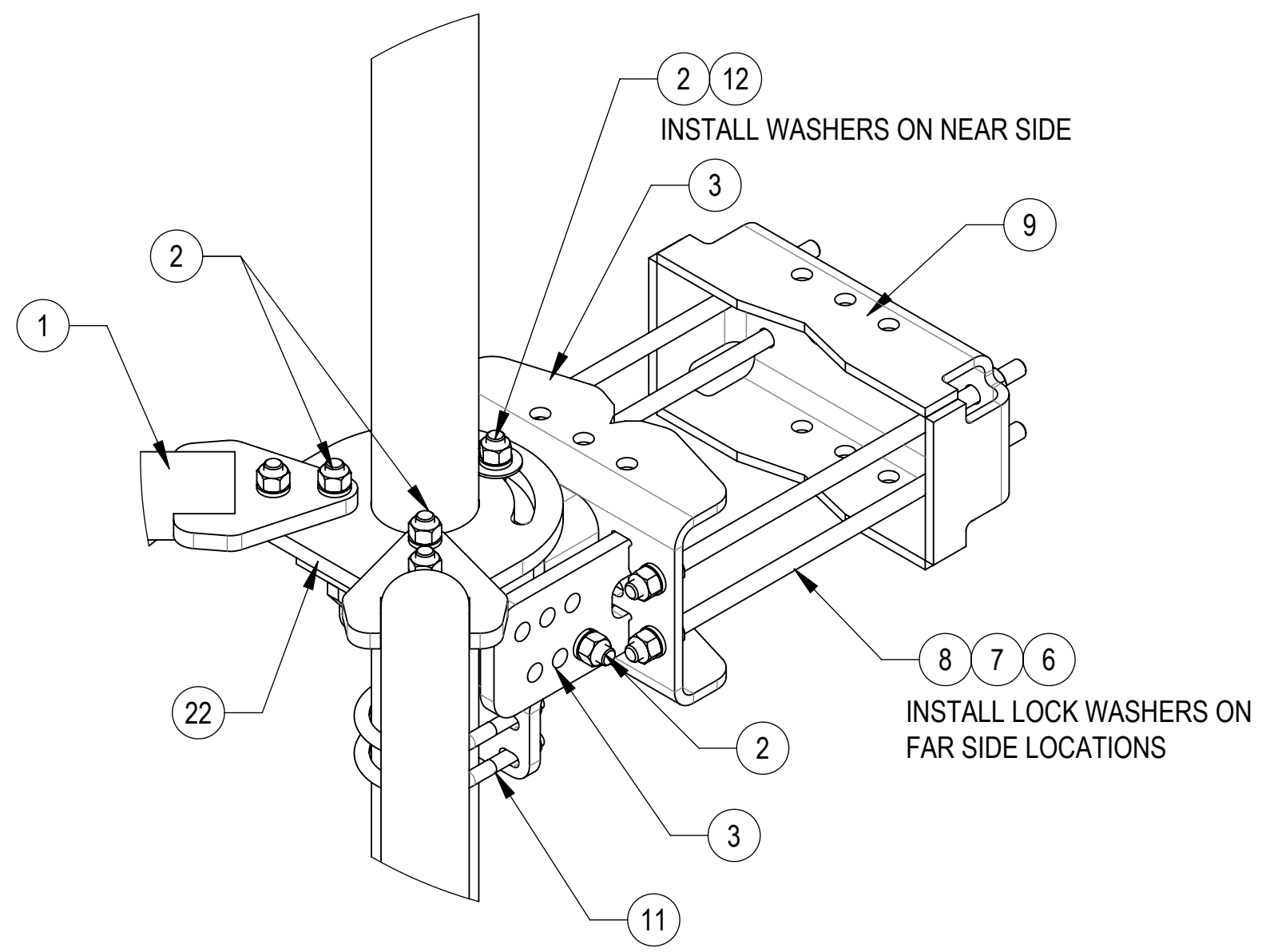

DETAIL B
SCALE 1 : 5

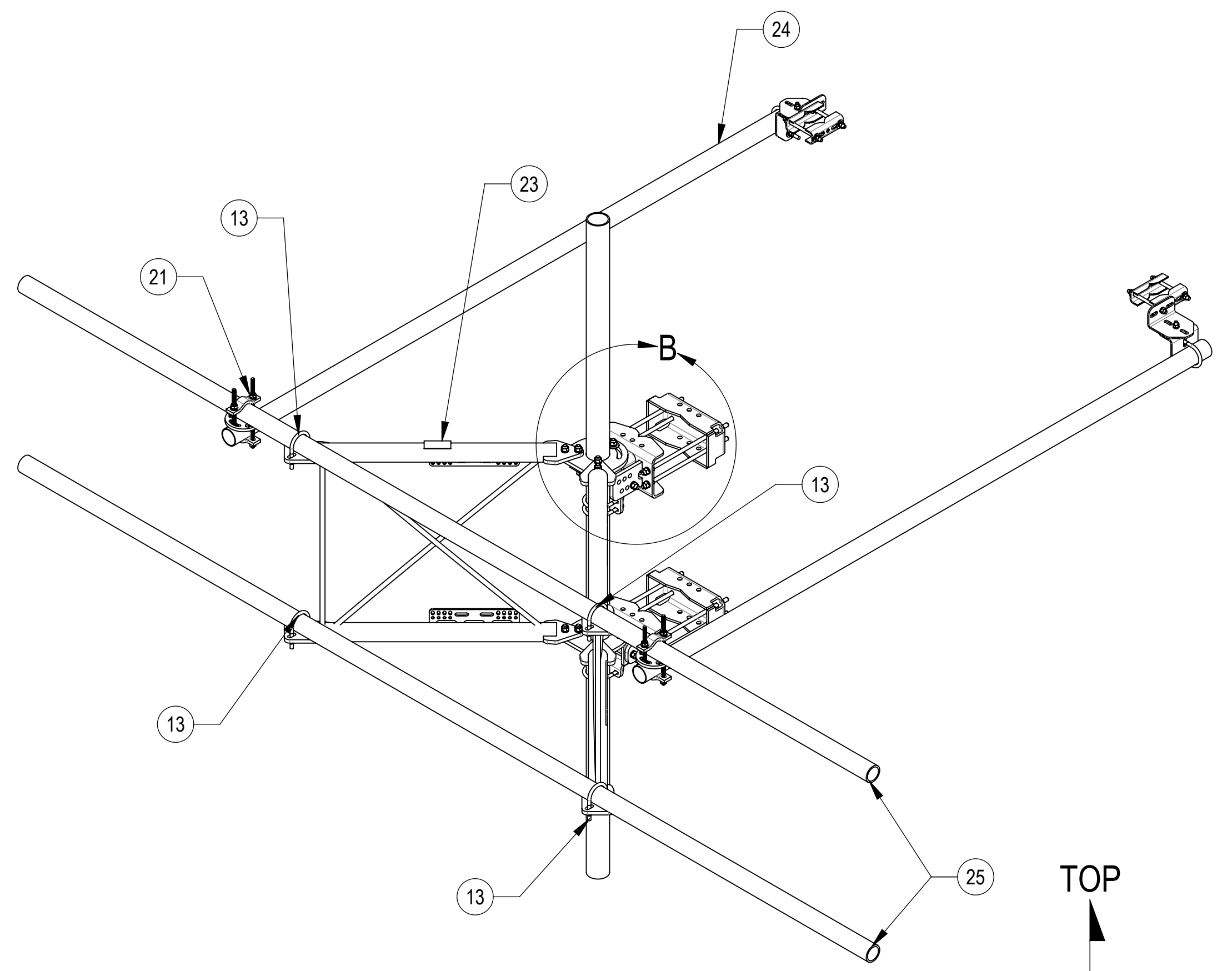

ALLOWABLE TIEBACK ANGLE
±15 DEGREES VERTICAL
±25 DEGREES HORIZONTAL

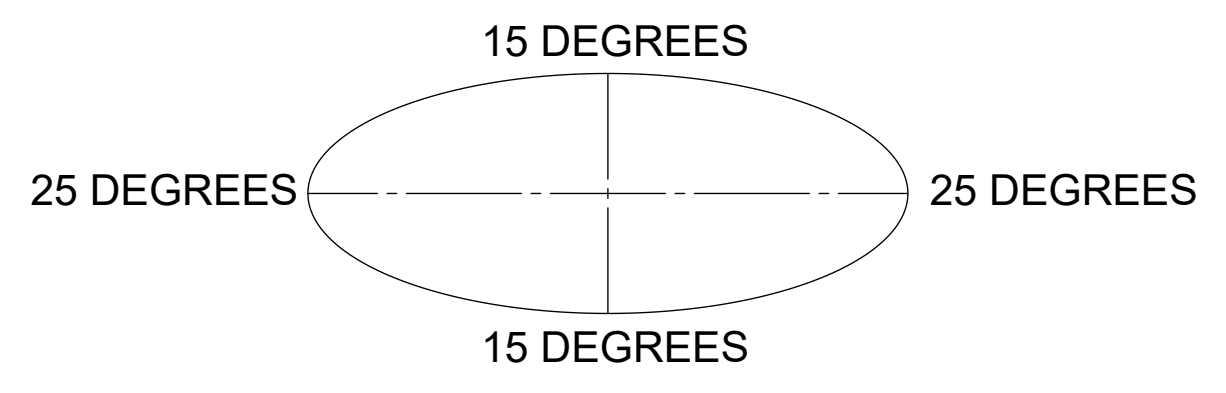

COMPONENT PART NUMBERS PROVIDED FOR ASSEMBLY PURPOSES;
INDIVIDUAL COMPONENTS MAY BE SHIPPED AS PARTS WITHIN AN INCLUDED KIT.

ITEM	PART NO.	DESCRIPTION	QTY.	WEIGHT	NOTE NO.
1	SFG23175	ARM STANDOFF SFG23	2	66.67 LBS	
2	GB-05225	5/8" X 2-1/4" GALV BOLT KIT	14	0.28 LBS	
3	SFG2380	WELDMENT, HD, TOP TAPER BRACKET	1	22.78 LBS	
4	SFG2386	WELDMENT, SFG2 AZIMUTH BRACKET	1	10.07 LBS	
5	SFG2397-00	WELDMENT, G23 AZIMUTH BRACKET	1	7.94 LBS	
6	GN-05	5/8" GALV HEX NUT	24	0.08 LBS	
7	GWL-05	5/8" GALV LOCK WASHER	16	0.03 LBS	
8	MT-382-18	5/8" X 18" THREADED ROD	8	1.43 LBS	
9	SFG2289	G2 RRU BACK CLAMP, HD	2	18.65 LBS	
10	SFG2381	WELDMENT, HD, LOWER TOWER LEG BRACKET	1	17.42 LBS	
11	GUB-4355	1/2" X 3-5/8" X 5" GALV U-BOLT	3	0.71 LBS	
12	GWF-05	5/8" GALV FLAT WASHER, 1.7OD	2	0.06 LBS	
13	GUB-4352	1/2" X 3" X 5-1/4" GALV U-BOLT	6	0.71 LBS	
14	SAB01	FORMED CLAMP	4	1.35 LBS	
15	MT-379-8	1/2" X 8" GALV THREADED ROD	4	0.45 LBS	
16	XAU01	ANGLE, CROSSOVER, 1.9-3.5" X 1.9-3.5" OD	4	2.98 LBS	
17	GB-04145	1/2" X 1-1/2" GALV BOLT KIT	2	0.13 LBS	
18	GWF-04	1/2" GALV FLAT WASHER	8	0.04 LBS	
19	GWL-04	1/2" GALV LOCK WASHER	10	0.01 LBS	
20	GN-04	1/2" GALV HEX NUT	10	0.04 LBS	
21	XP-R	CROSSOVER PLATE, ROUND, UP TO 3.5" OD	2	6.20 LBS	
22	SFG2204	WELDMENT, BACK VERTICAL ARM MOUNT	1	97.29 LBS	
23	SFG2398	LABEL, SFG23RHDX	1	0.04 LBS	
24	MT546120120	PIPE, 2.875"OD X 120"	2	35.44 LBS	
25	MT546180276	PIPE, 2.875"OD X 180"	2	115.33 LBS	

COMMSCOPE, INC. OF NORTH CAROLINA				
TITLE SF,15'FP,NOAP				
SIZE C	SCALE 1:32	DOCUMENT NO. SFG23RHDX-15-B		
DRAWING		VERSION	STATUS	REVISION
SHEET 2 OF 6		01	RE	B

TIEBACK MUST BE CONNECTED TO A RIGID MEMBER THAT PROVIDES ADEQUATE SUPPORT WITHIN THE LIMITS NOTED IN THE TIEBACK ANGLE RANGE DETAIL. UNLESS APPROVED BY ENGINEER OF RECORD. SPINE STEM OF NEIGHBORING MOUNT IS ACCEPTABLE.

ALLOWABLE TIEBACK ANGLE

±15 DEGREES VERTICAL
±25 DEGREES HORIZONTAL

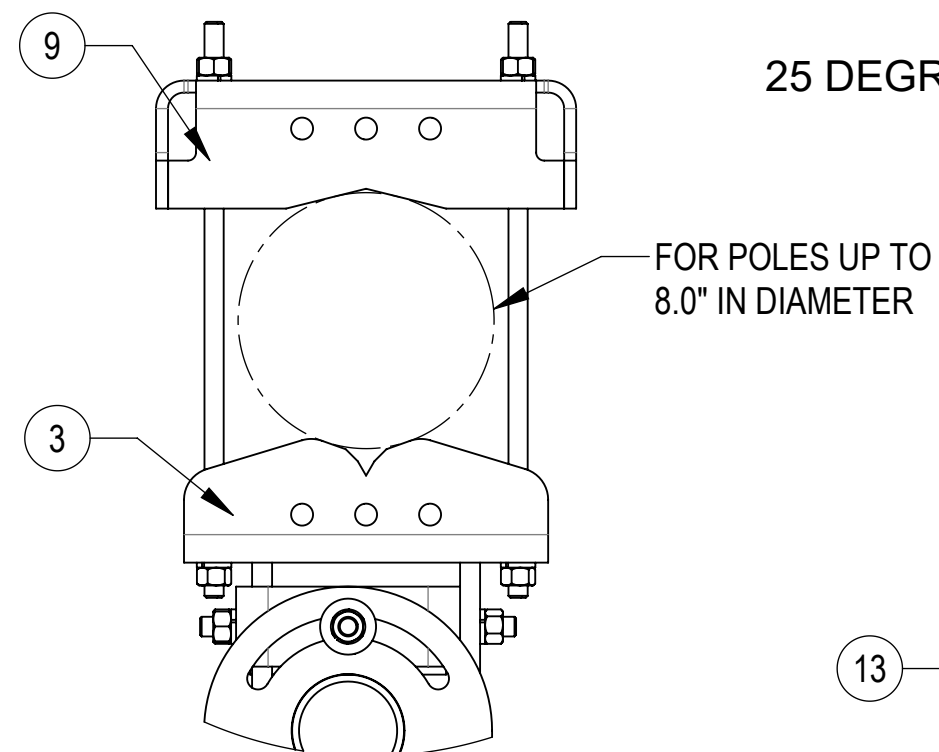
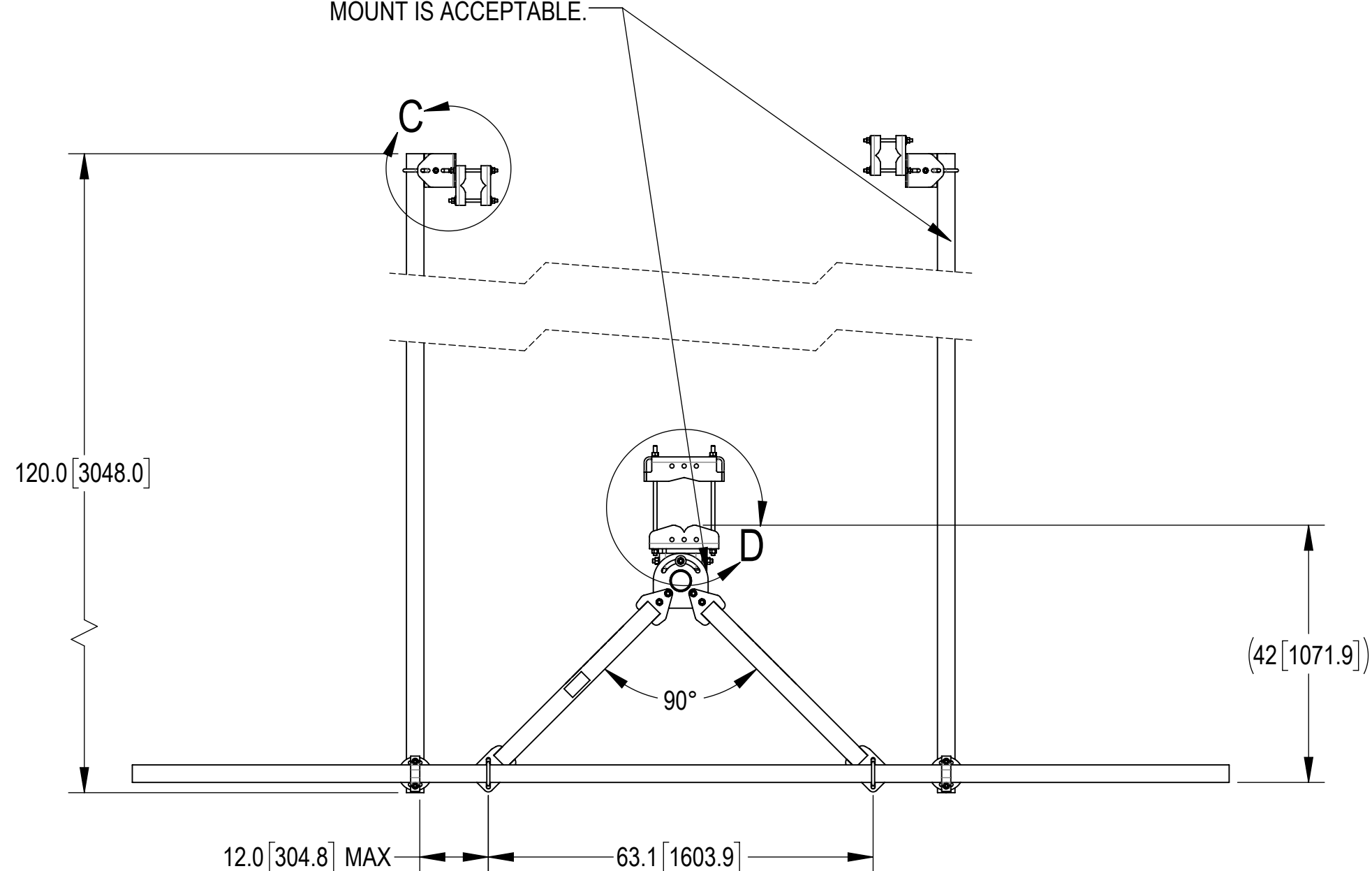
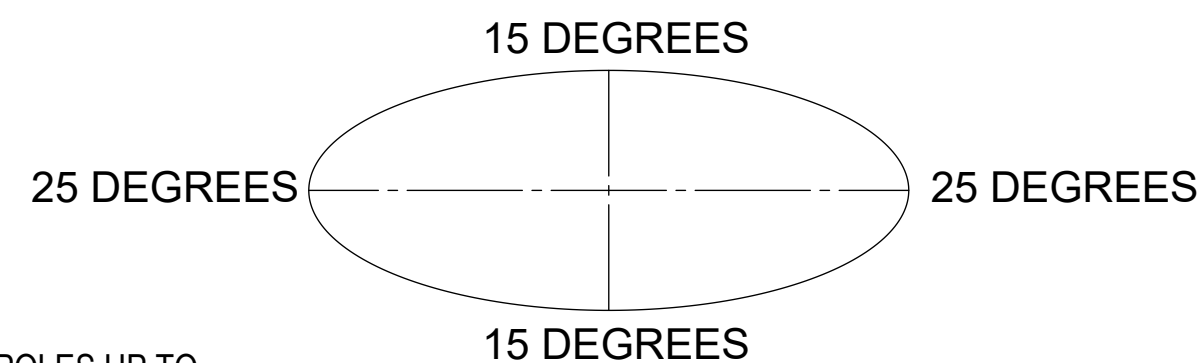

DETAIL D
SCALE 1:6

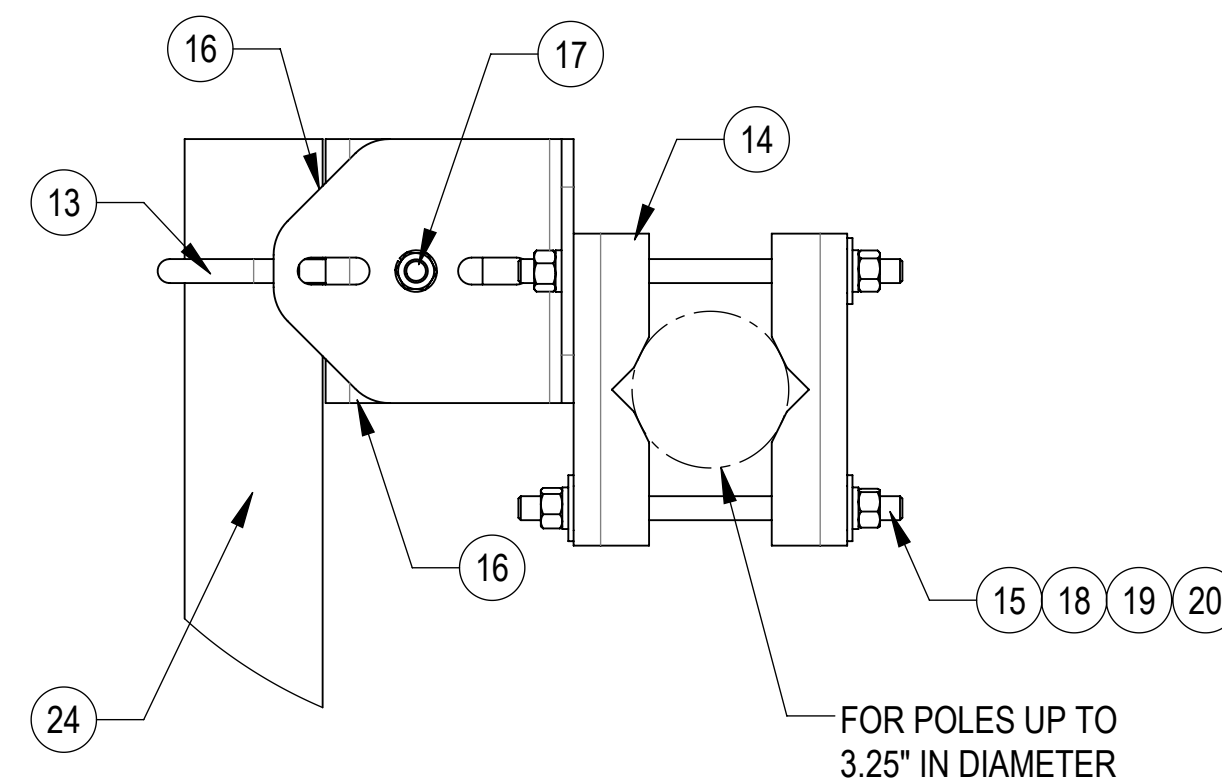

DETAIL C
SCALE 1:4

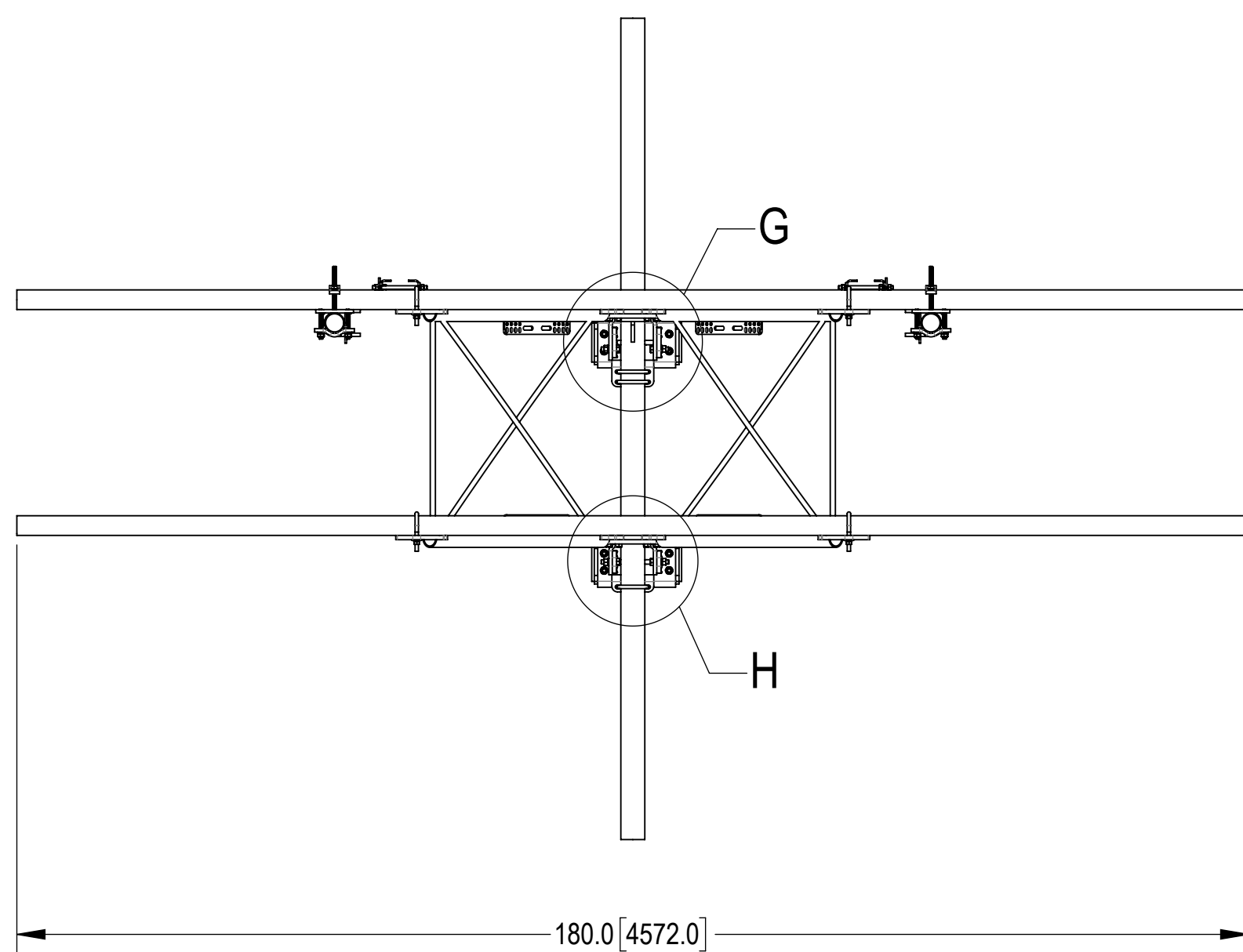

TOP
BOTTOM

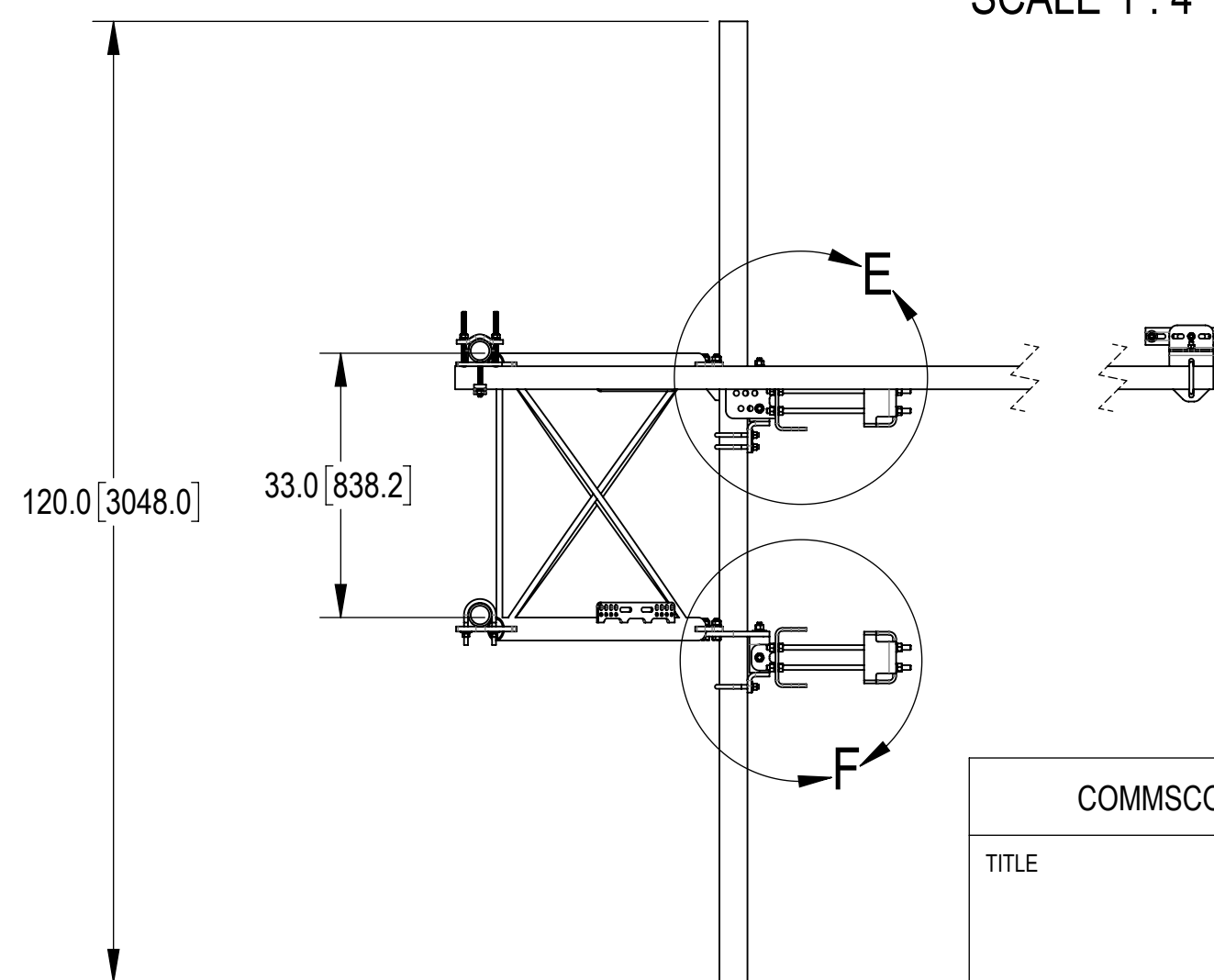

COMMSCOPE, INC. OF NORTH CAROLINA				
TITLE SF,15'FP,NOAP				
SIZE C	SCALE 1:22	DOCUMENT NO. SFG23RHDX-15-B		
		DRAWING		SHEET
		VERSION	STATUS	REVISION
		01	RE	B
				3 OF 6

4

3

2

1

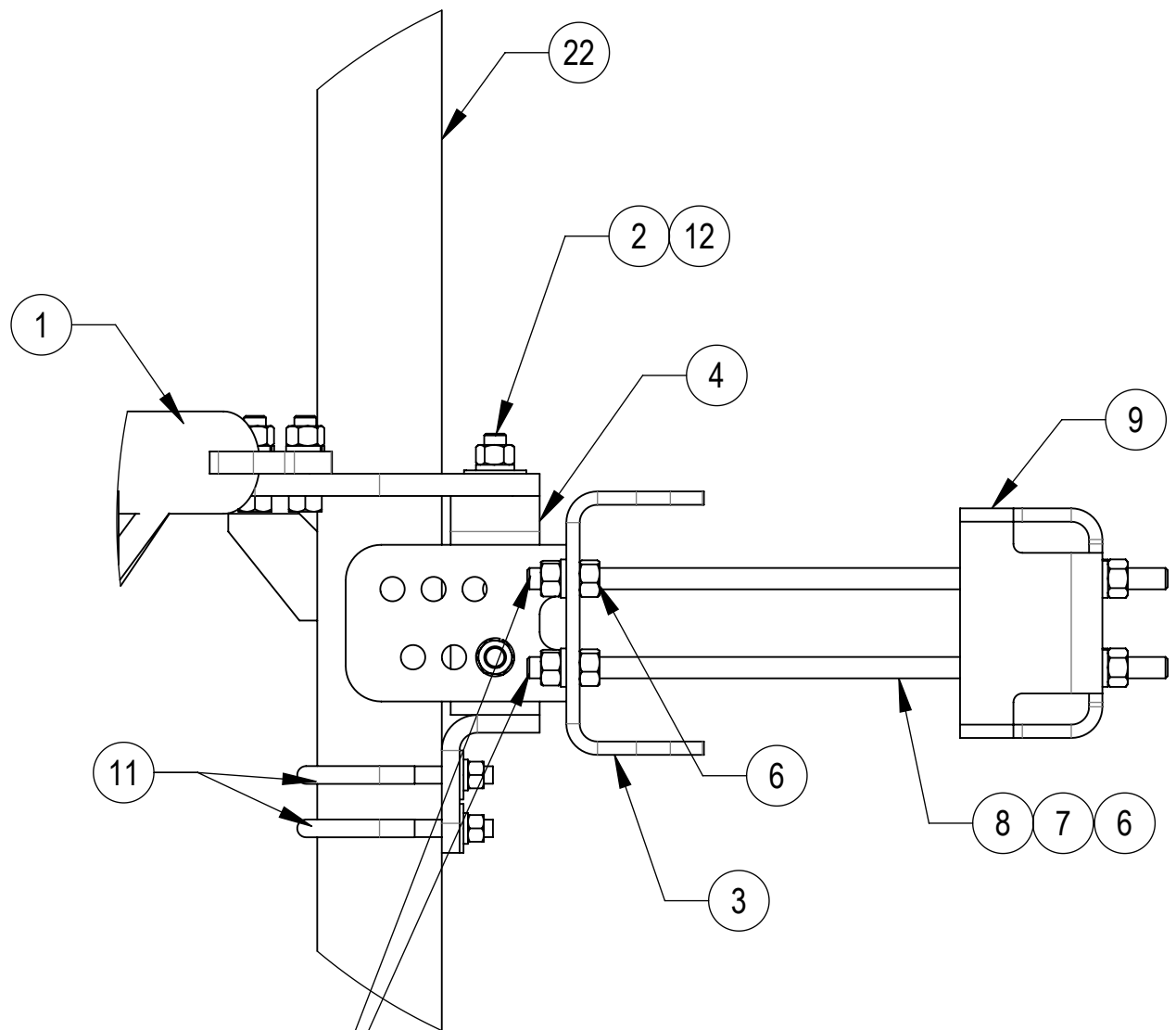

DETAIL E
SCALE 1 : 5

THE THREADED ROD CAN ONLY EXPOSE 4 TO 7
THREADS ON ONE SIDE OF THE BRACKET, WHICH IS
TO PREVENT INTERFERENCE WITH THE SIDE BOLTS

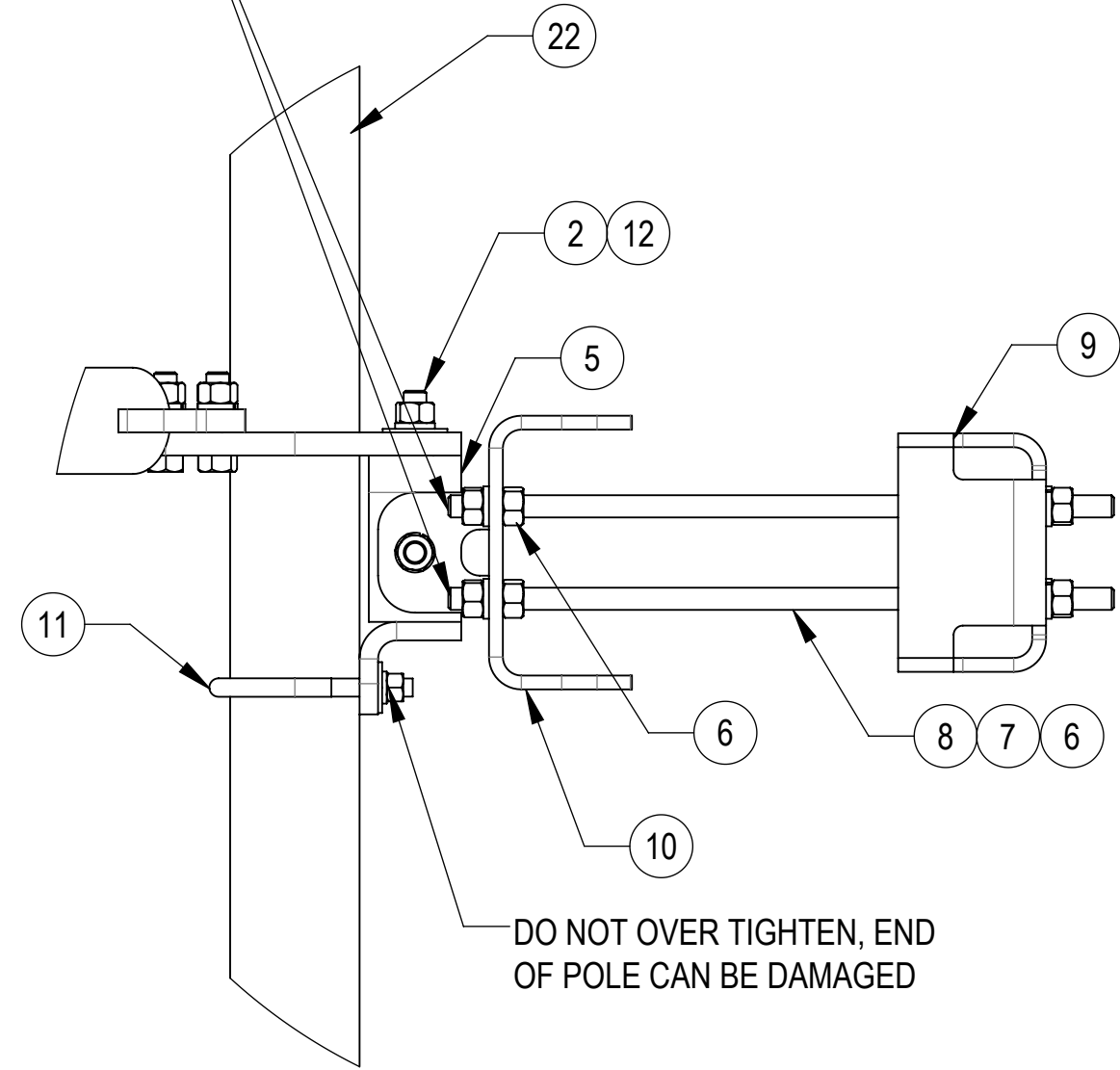

DETAIL F
SCALE 1 : 5

DO NOT OVER TIGHTEN, END
OF POLE CAN BE DAMAGED

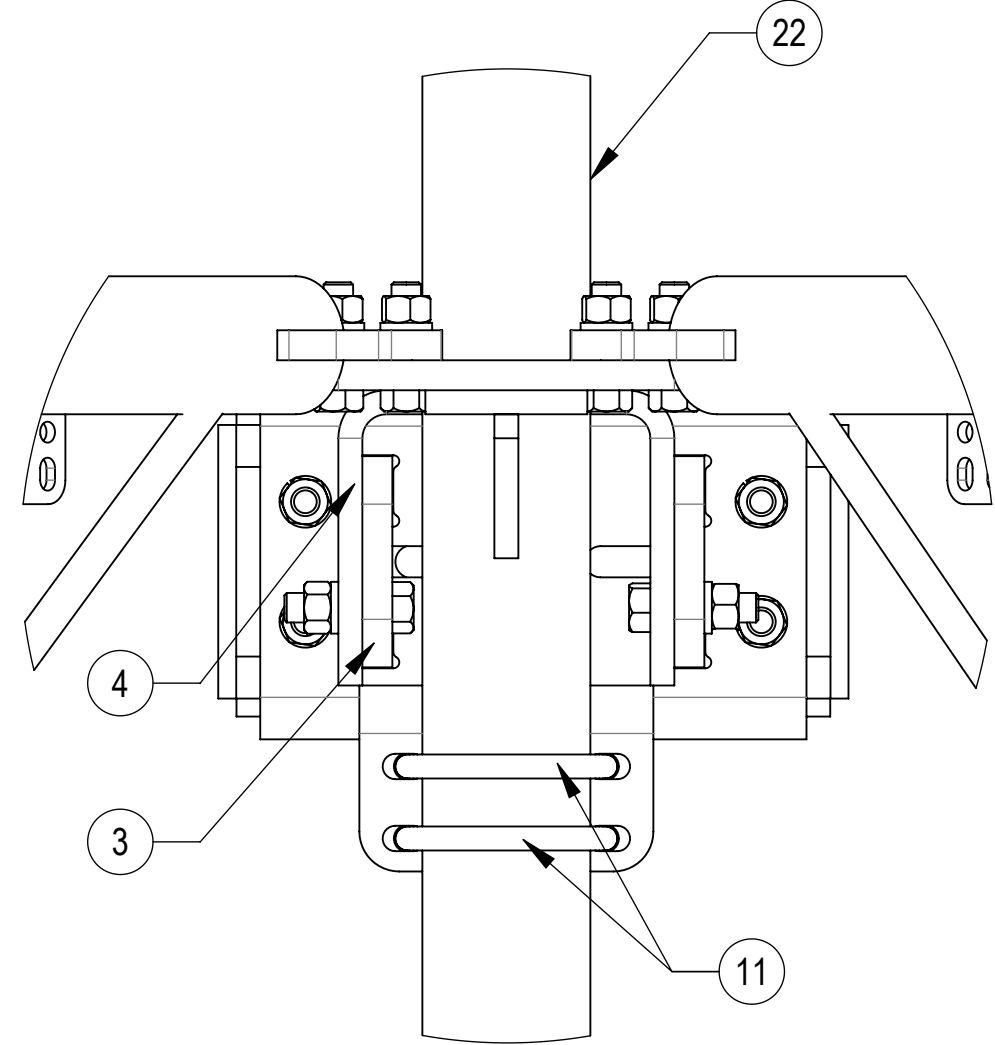

DETAIL G
SCALE 1 : 4

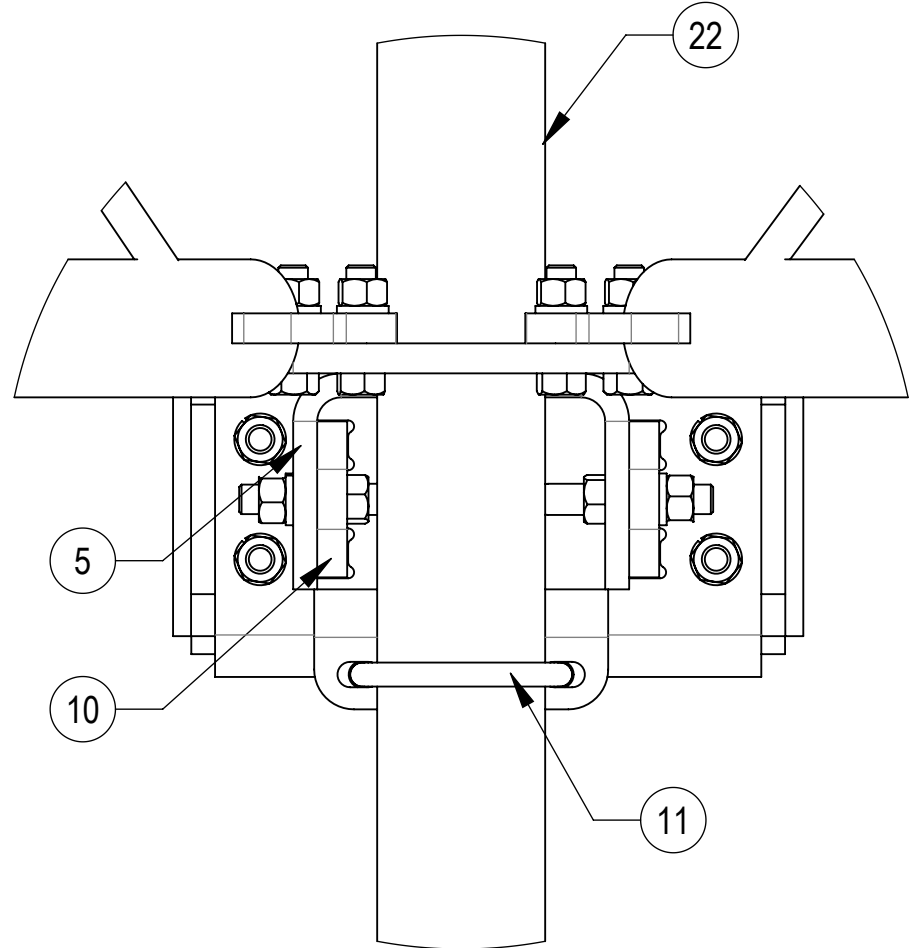

DETAIL H
SCALE 1 : 4

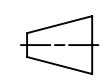
COMMSCOPE, INC. OF NORTH CAROLINA				
TITLE SF,15'FP,NOAP				
SIZE C	SCALE 1:22	DOCUMENT NO. SFG23RHDx-15-B		
 		DRAWING		SHEET
		VERSION 01	STATUS RE	REVISION B

4

3

2

1

D

D

C

C

B

B

A

A

4

3

2

1

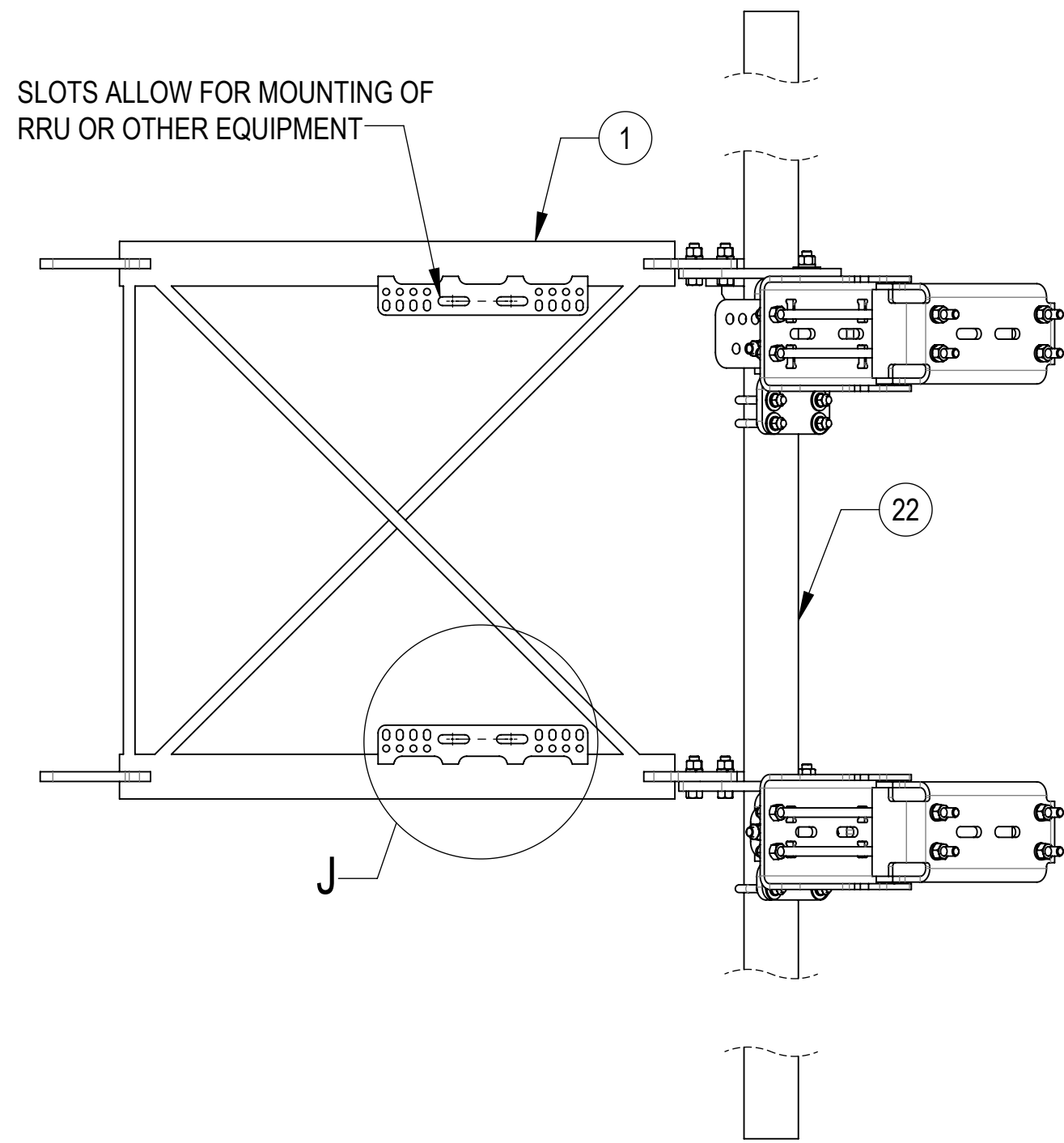

SIDE VIEW

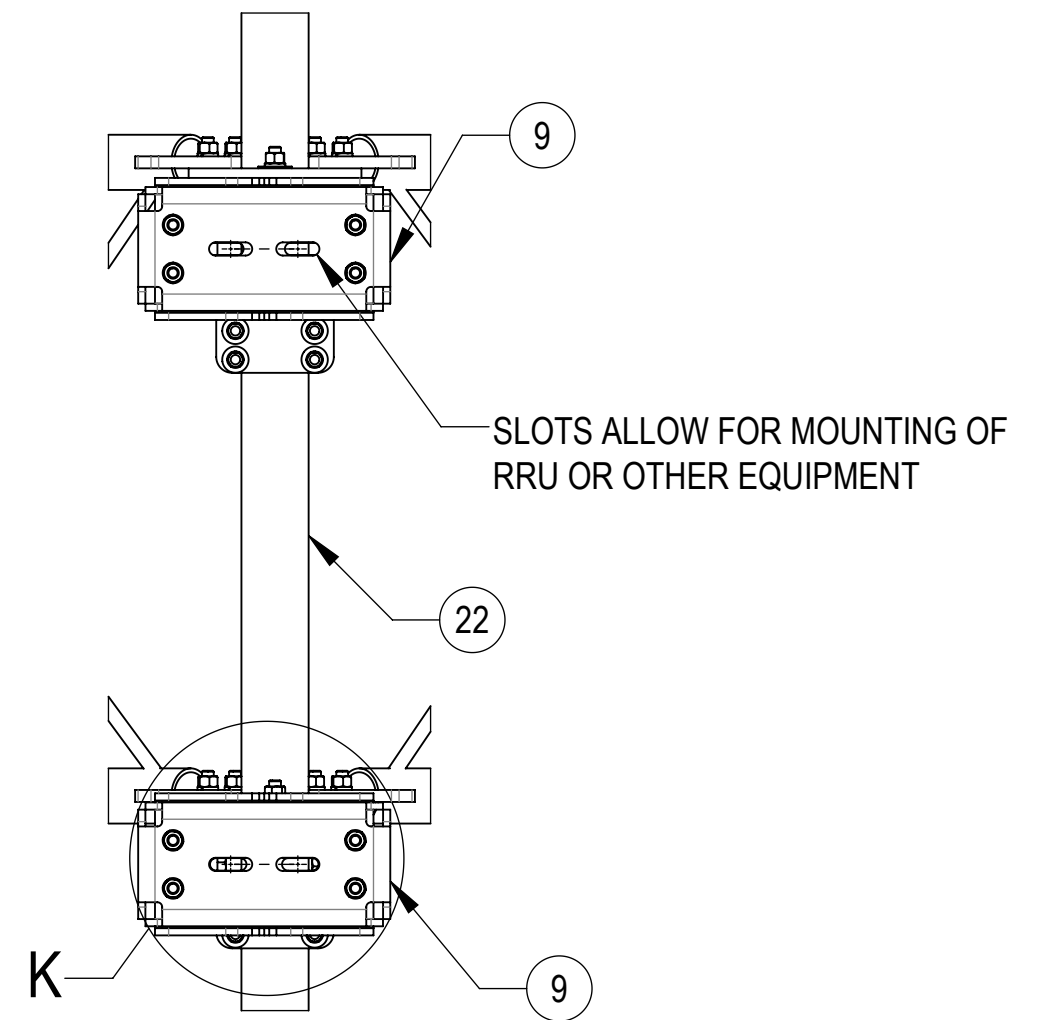

BACK CROP VIEW

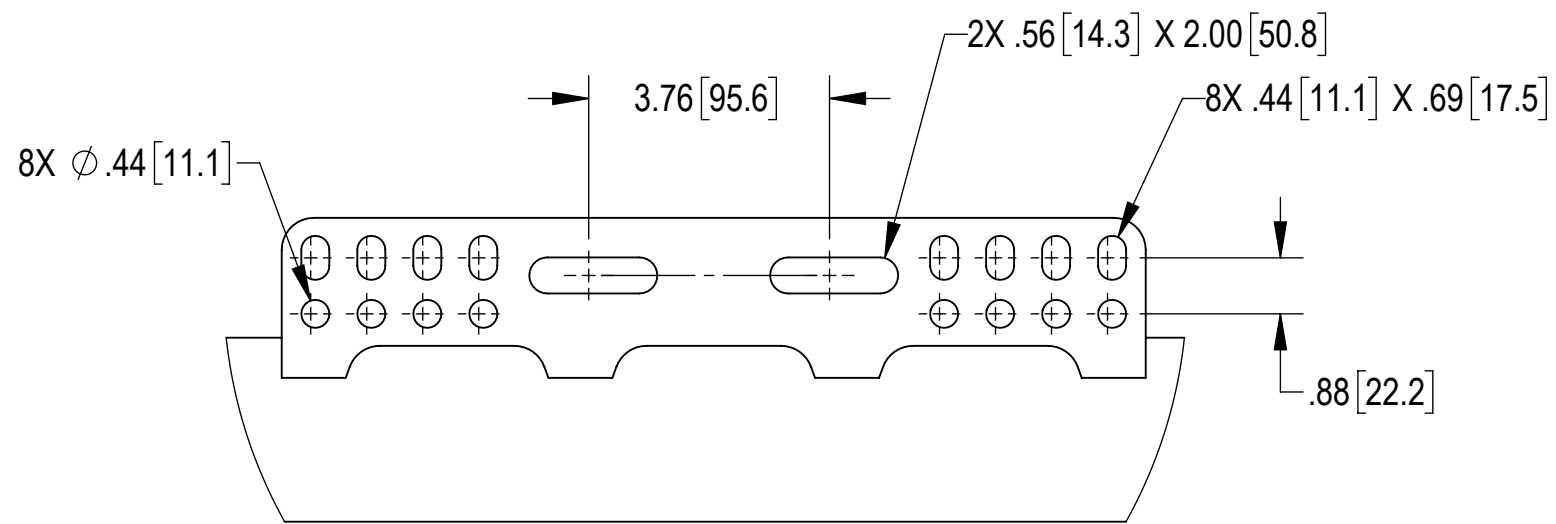

DETAIL J
SCALE 1 : 3

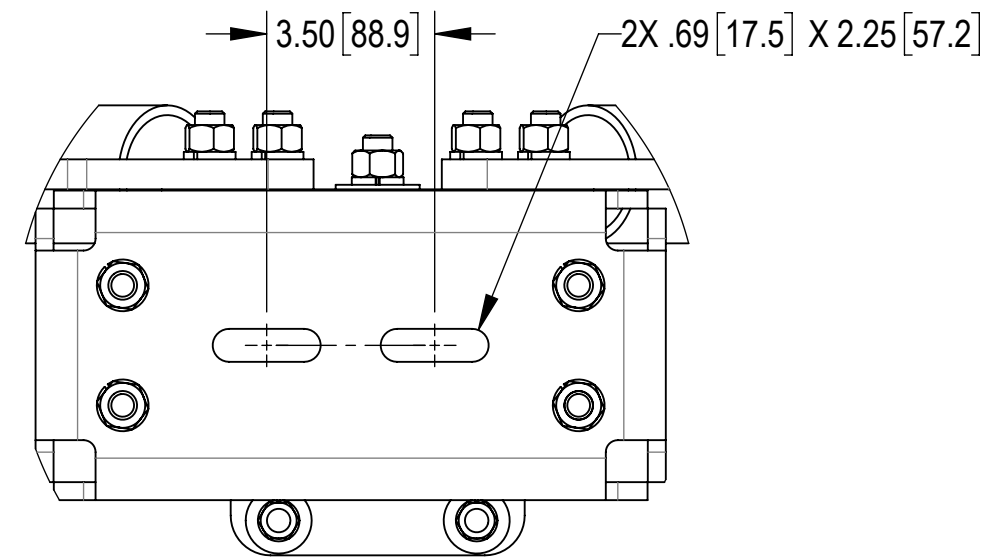

DETAIL K
SCALE 1 : 4

COMMSCOPE, INC. OF NORTH CAROLINA				
TITLE SF,15'FP,NOAP				
SIZE C	SCALE 1:10	DOCUMENT NO. SFG23RHDX-15-B		
		DRAWING		SHEET 5 OF 6
		VERSION 01	STATUS RE	

4

3

2

1

ACCESSORIES ORDERED SEPARATELY:

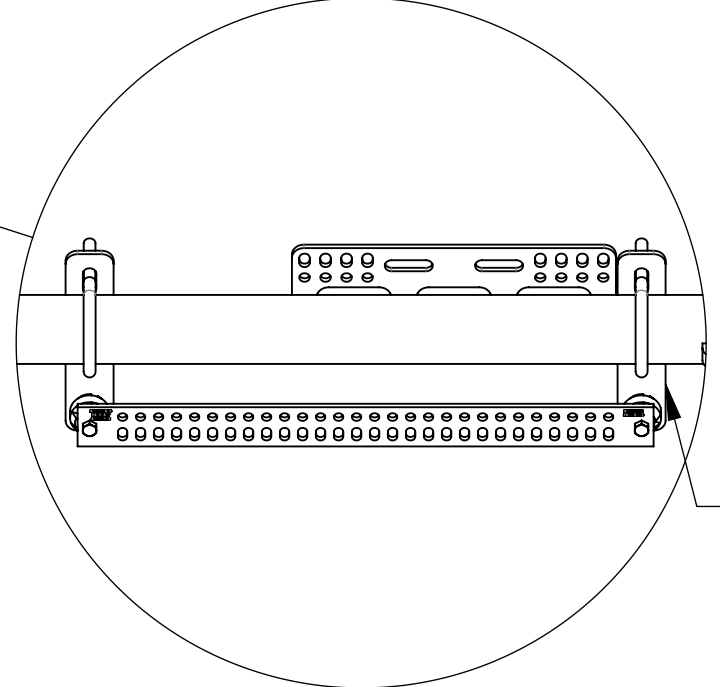
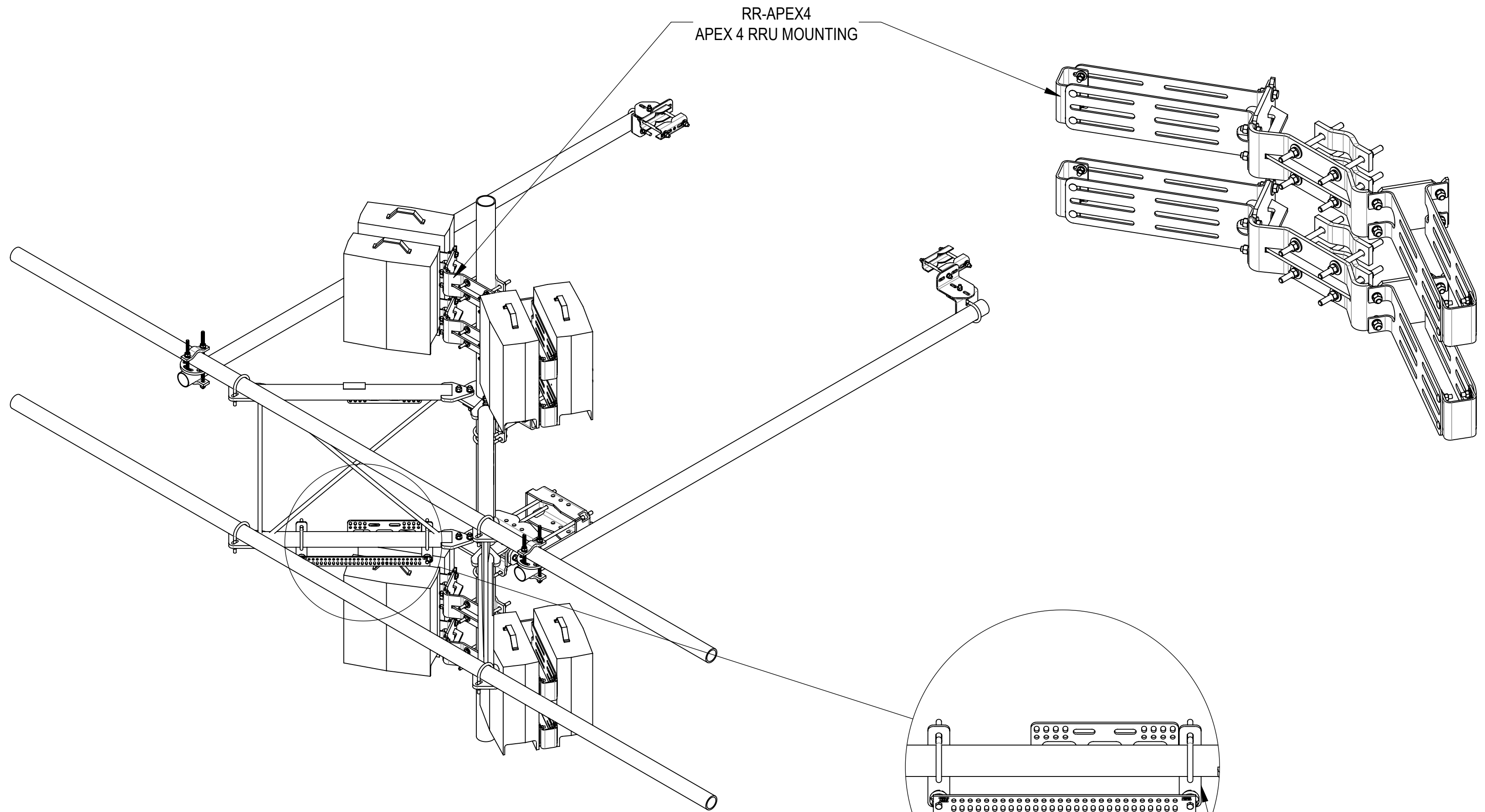

GBSF278

DETAIL L
SCALE 1:8

COMMSCOPE, INC. OF NORTH CAROLINA					
TITLE					
SF,15'FP,NOAP					
SIZE	SCALE	DOCUMENT NO.			
C	1:14	SFG23RHDY-15-B			
		DRAWING			SHEET
		VERSION	STATUS	REVISION	6 OF 6
		01	RE	B	