

4

3

2

1

- 1.0 GENERAL NOTES
 - 1.1 ALL METRIC DIMENSIONS ARE IN BRACKETS [X.X]
 - 1.2 FOR PATENT INFO: <https://www.cs-pat.com>
- 2.0 DESIGN NOTES
 - 2.1 ANY HAZARDS OR OBSTRUCTIONS TO THE CLIMBING FACILITY AND SAFETY CLIMB MUST BE IDENTIFIED PRIOR TO INSTALLING THE APPURTENANCE. ADDITIONAL PRODUCTS MAY BE REQUIRED TO MAINTAIN THE INTEGRITY OF THE SAFETY CLIMB. DURING INSTALLATION, TEMPORARY AND/OR PERMANENT PRECAUTIONARY MEASURES SHOULD BE TAKEN TO PRESERVE THE CLIMBING FACILITY AND/OR SAFETY CLIMB.
 - 2.2 UP TO 5.0° TAPER AVAILABLE ON MODELS THAT SUPPORT ADJUSTMENT
- 3.0 MANUFACTURING/SPECIAL REQUIREMENTS
 - 3.1 TIGHTEN ALL BOLTS SECURING FLAT PLATES BY THE TURN-OF-NUT METHOD. TIGHTEN ALL U-BOLTS USING TURN-OF-NUT METHOD WITH ATTENTION TO LEAVE EQUAL DISTANCE AND EQUAL FORCE ON EACH LEG OF THE U-BOLT.
- 4.0 TEST
- 5.0 PACKAGING
 - 5.1 PACKAGING SHALL MEET COMMSCOPE REQUIREMENTS PER DOCUMENT IS-PL-3005.
 - 5.2 PRINTED DOCUMENT TO BE PLACED INSIDE POLYBAG AND THEN IN SHIPPING CONTAINER.
 - 5.3 EXTRA HARDWARE MAY BE SUPPLIED, BAGGED AND SHIPPED.

REVISIONS			
REV.	DESCRIPTION	DATE	APPROVED
A	INITIAL RELEASE	JL1183 24MAY24	CB1094 40196505CMO
B	UPDATED SFG23175 TO ADD UNIVERSAL INTERFACE PLATES	RY1002 02SEP24	XK1001 40202713CMO

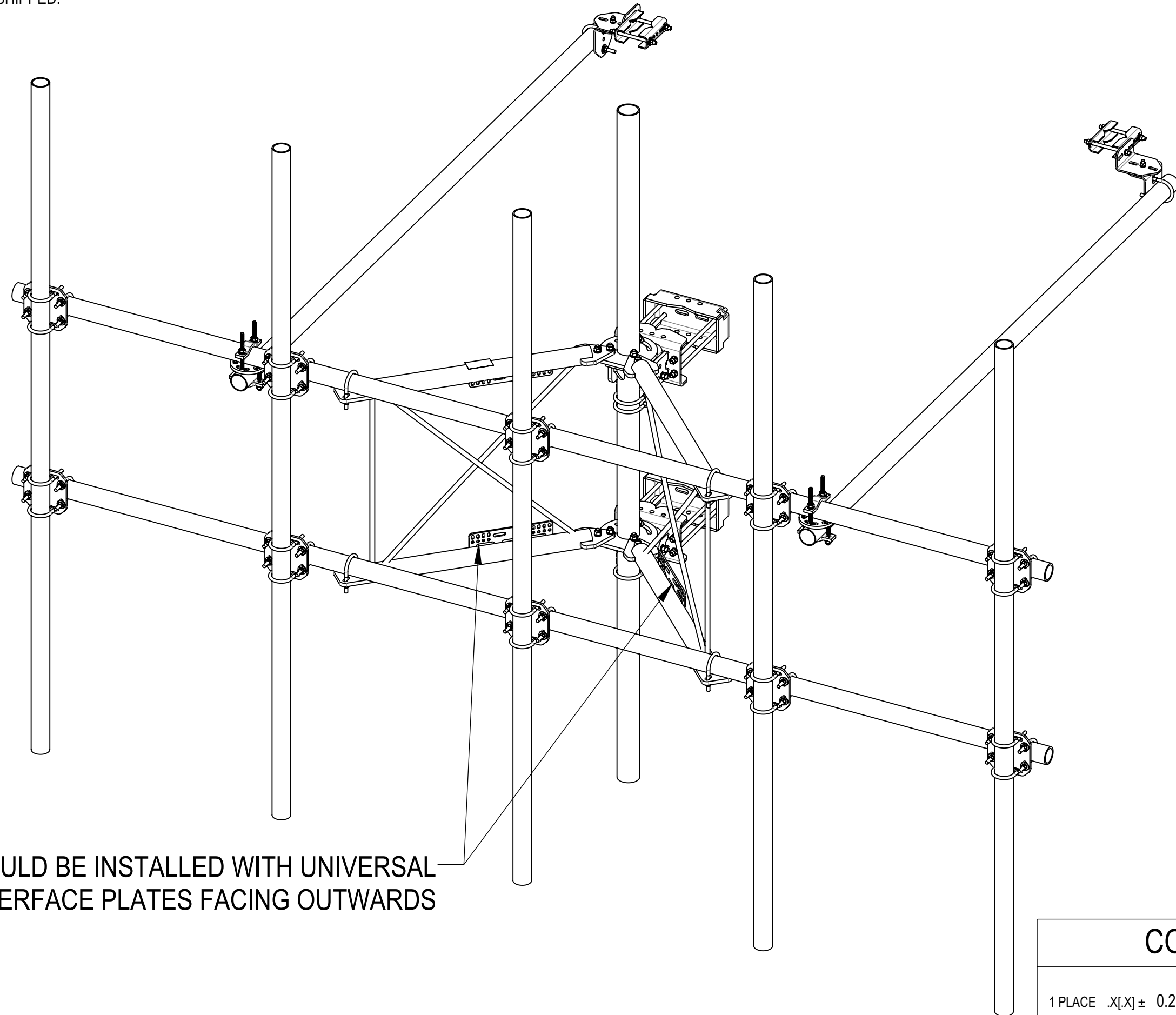

SHOULD BE INSTALLED WITH UNIVERSAL
INTERFACE PLATES FACING OUTWARDS

COMMSCOPE, INC. OF NORTH CAROLINA												
TOLERANCES						SAP MATERIAL MASTER						
1 PLACE .X[X] ± 0.2[6.3]			3 PLACE .XXX[X] ± 0.060[1.5]			SFG23RHDX-15-5-120						
2 PLACE .XX[X] ± 0.12[3.0]			ANGLES ± 2°									
FINISH						MATERIAL						
PG,SF,15'FP,(5)120"AP												
UNLESS OTHERWISE SPECIFIED DIMENSIONS ARE IN INCHES INTERPRET PER ANSI Y 14.5M-1994			NAME		DATE		TITLE					
CE		JL1183		24MAY24		SFG23RHDX-15-5-120						
RW		RY1002		09/04/2024								
AD		XK1001		09/05/2024								
RE		RY1002		09/14/2024								
ECN 40202713CMO			SCALE		DOCUMENT NO.							
			1:16		SFG23RHDX-15-5-120							
SIZE		Auth Group		INSL		MODEL			DRAWING			SHEET
C		[Symbol]		[Symbol]		VERSION			STATUS			REVISION
						01			RE			B
						01			RE			B

DENSITY		lbs/in ³
MASS	1059.02	lbs
VOLUME	3733.61	in ³
SURFACE AREA	33154.62	in ²
HEIGHT	120"	
LENGTH	180"	
WIDTH	120"	

4

3

2

1

4

3

2

1

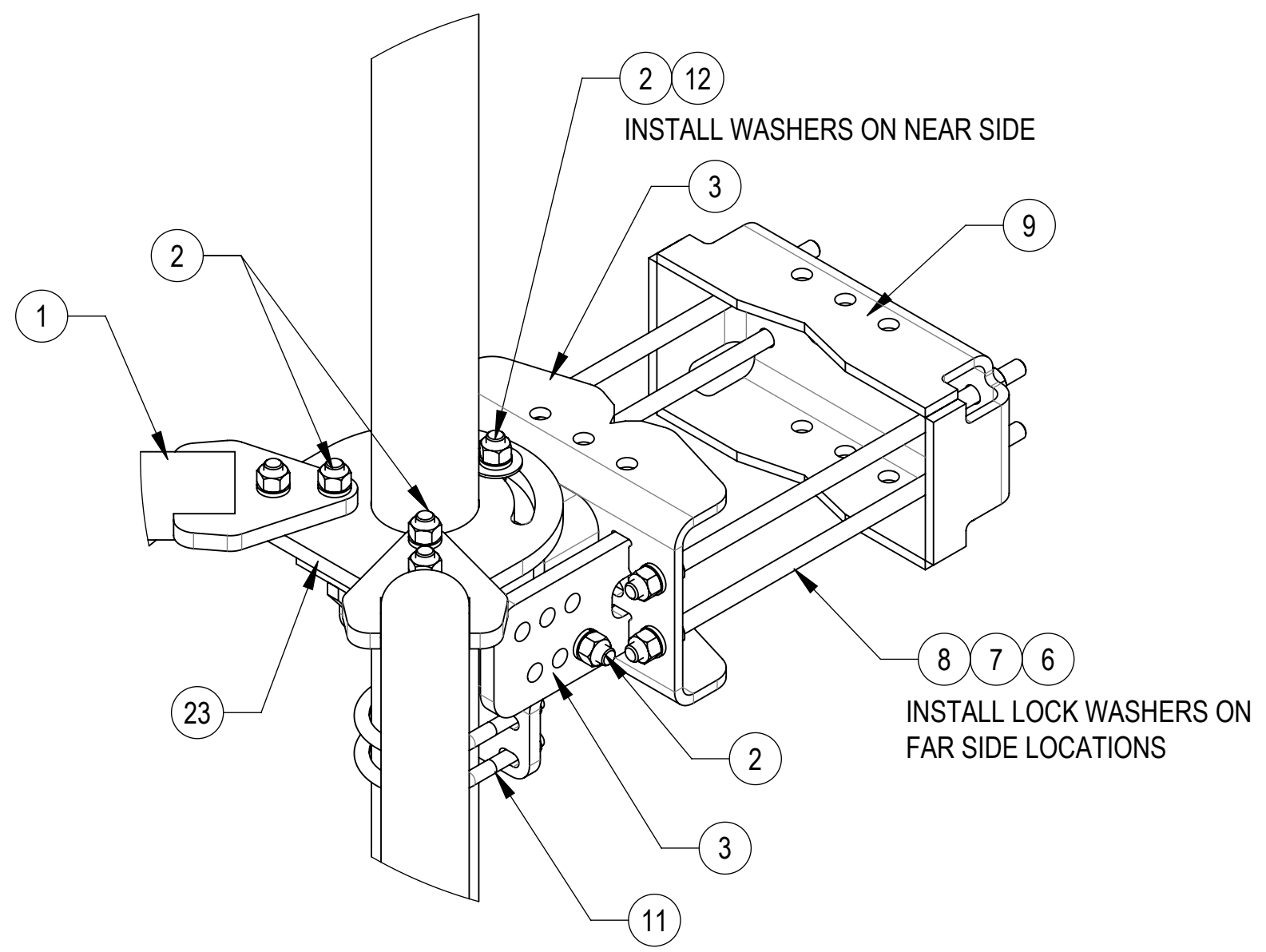

DETAIL B
SCALE 1 : 5

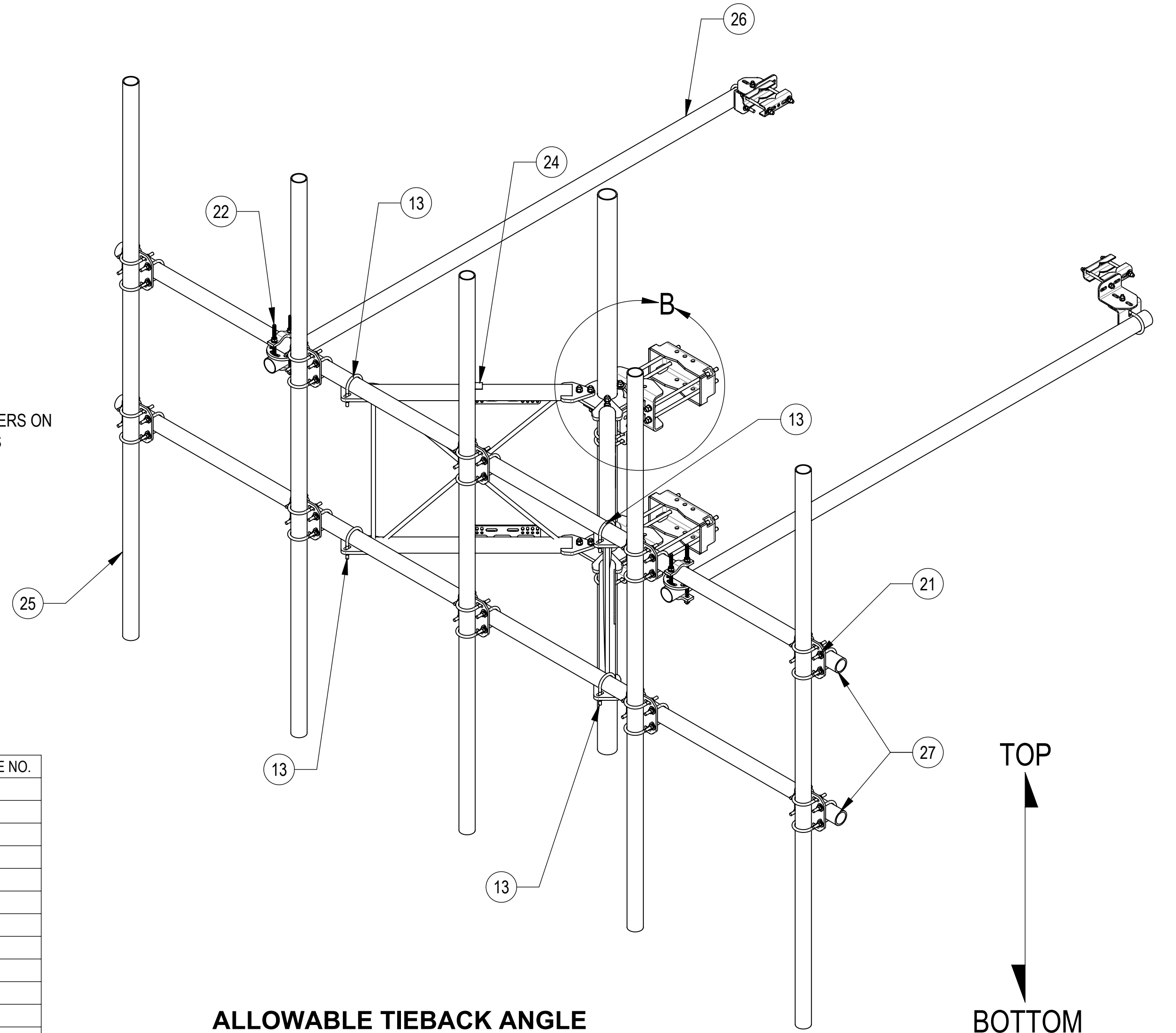

COMPONENT PART NUMBERS PROVIDED FOR ASSEMBLY PURPOSES;
INDIVIDUAL COMPONENTS MAY BE SHIPPED AS PARTS WITHIN AN INCLUDED KIT.

ITEM	PART NO.	DESCRIPTION	QTY.	WEIGHT	NOTE NO.
1	SFG23175	ARM STANDOFF SFG23	2	66.67 LBS	
2	GB-05225	5/8" X 2-1/4" GALV BOLT KIT	14	0.28 LBS	
3	SFG2380	WELDMENT, HD, TOP TAPER BRACKET	1	22.78 LBS	
4	SFG2386	WELDMENT, SFG2 AZIMUTH BRACKET	1	10.07 LBS	
5	SFG2397-00	WELDMENT, G23 AZIMUTH BRACKET	1	7.94 LBS	
6	GN-05	5/8" GALV HEX NUT	24	0.08 LBS	
7	GWL-05	5/8" GALV LOCK WASHER	16	0.03 LBS	
8	MT-382-18	5/8" X 18" THREADED ROD	8	1.43 LBS	
9	SFG2289	G2 RRU BACK CLAMP, HD	2	18.65 LBS	
10	SFG2381	WELDMENT, HD, LOWER TOWER LEG BRACKET	1	17.42 LBS	
11	GUB-4355	1/2" X 3-5/8" X 5" GALV U-BOLT	3	0.71 LBS	
12	GWF-05	5/8" GALV FLAT WASHER, 1.7OD	2	0.06 LBS	
13	GUB-4352	1/2" X 3" X 5-1/4" GALV U-BOLT	6	0.71 LBS	
14	SAB01	FORMED CLAMP	4	1.35 LBS	
15	MT-379-8	1/2" X 8" GALV THREADED ROD	4	0.45 LBS	
16	XAU01	ANGLE, CROSSOVER, 1.9-3.5" X 1.9-3.5" OD	4	2.98 LBS	
17	GB-04145	1/2" X 1-1/2" GALV BOLT KIT	2	0.13 LBS	
18	GWF-04	1/2" GALV FLAT WASHER	8	0.04 LBS	
19	GWL-04	1/2" GALV LOCK WASHER	10	0.01 LBS	
20	GN-04	1/2" GALV HEX NUT	10	0.04 LBS	
21	XP-2525	CROSSOVER PLATE KIT, 2-7/8 OD X 2-7/8 OD	10	8.37 LBS	
22	XP-R	CROSSOVER PLATE, ROUND, UP TO 3.5" OD	2	6.20 LBS	
23	SFG2204	WELDMENT, BACK VERTICAL ARM MOUNT	1	97.29 LBS	
24	SFG2398	LABEL, SFG23RHDX	1	0.04 LBS	
25	MT546120	PIPE, 2.875"OD X 120"	5	57.45 LBS	
26	MT546120120	PIPE, 2.875"OD X 120"	2	35.44 LBS	
27	MT546180276	PIPE, 2.875"OD X 180"	2	115.33 LBS	

COMMSCOPE, INC. OF NORTH CAROLINA				
TITLE PG,SF,15'FP,(5)120"AP				
SIZE C	SCALE 1:32	DOCUMENT NO. SFG23RHDX-15-5-120		
DRAWING		VERSION	STATUS	REVISION
SHEET		01	RE	B
2 OF 7				

© 2024 CommScope, Inc. Confidential

4

3

2

1

TIEBACK MUST BE CONNECTED TO A RIGID MEMBER THAT PROVIDES ADEQUATE SUPPORT WITHIN THE LIMITS NOTED IN THE TIEBACK ANGLE RANGE DETAIL. UNLESS APPROVED BY ENGINEER OF RECORD. SPINE STEM OF NEIGHBORING MOUNT IS ACCEPTABLE.

ALLOWABLE TIEBACK ANGLE

+15 DEGREES VERTICAL
±25 DEGREES HORIZONTAL

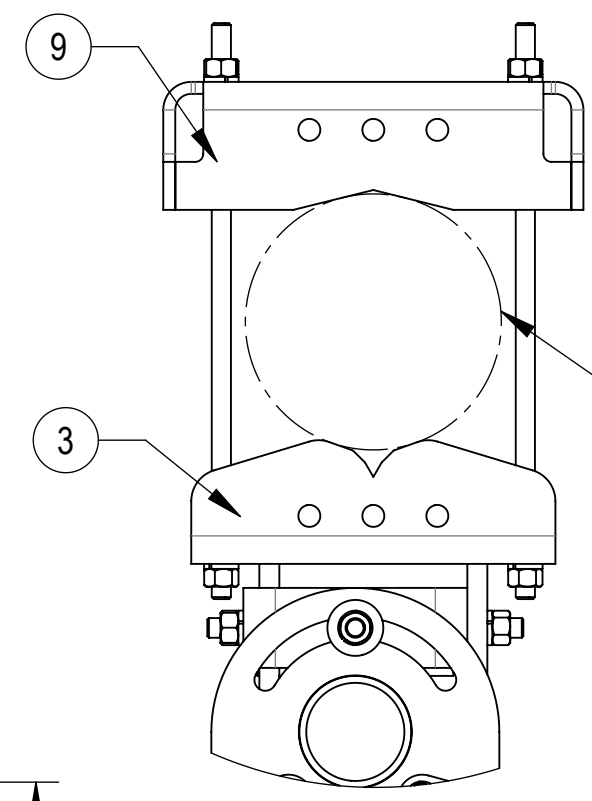
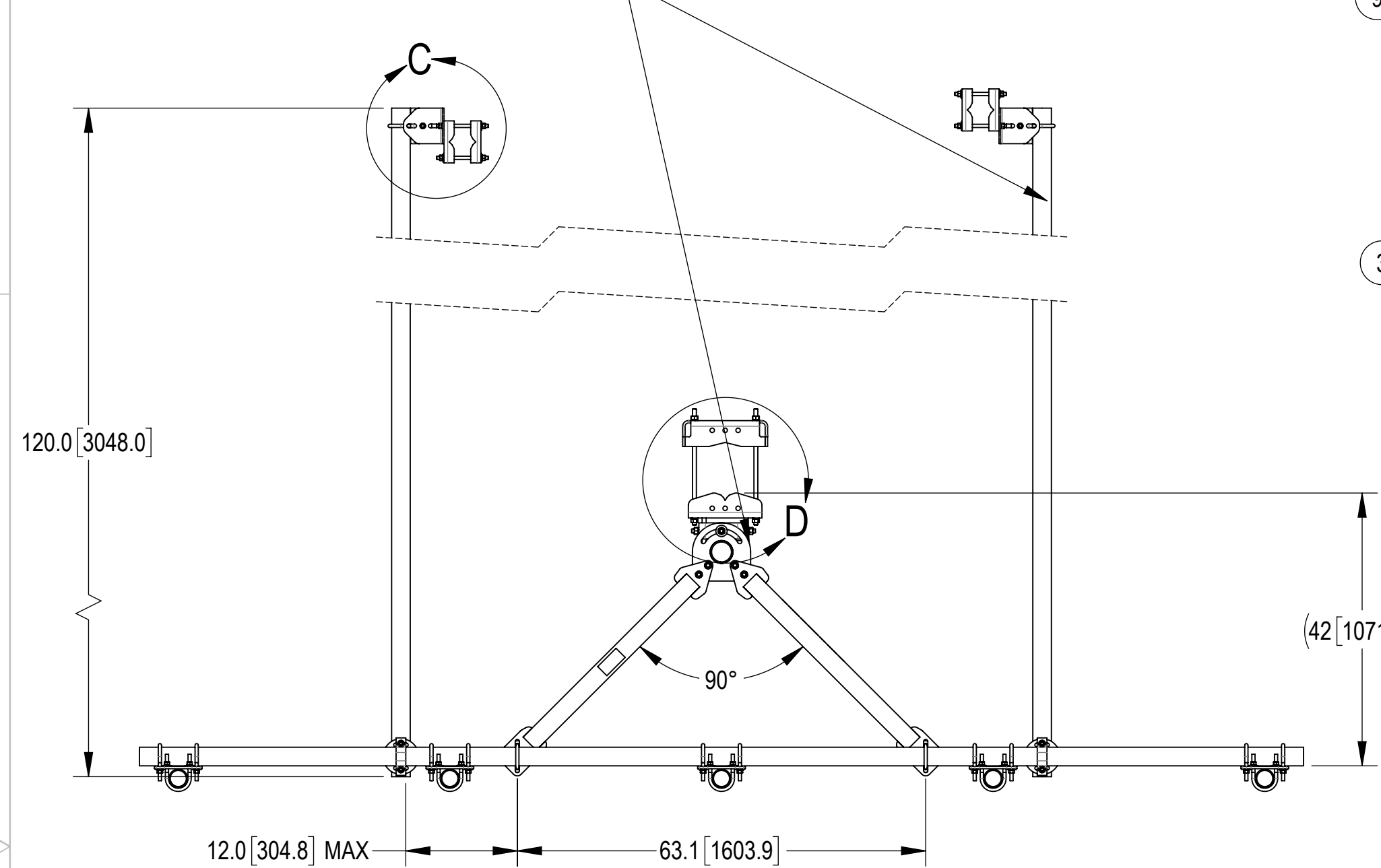
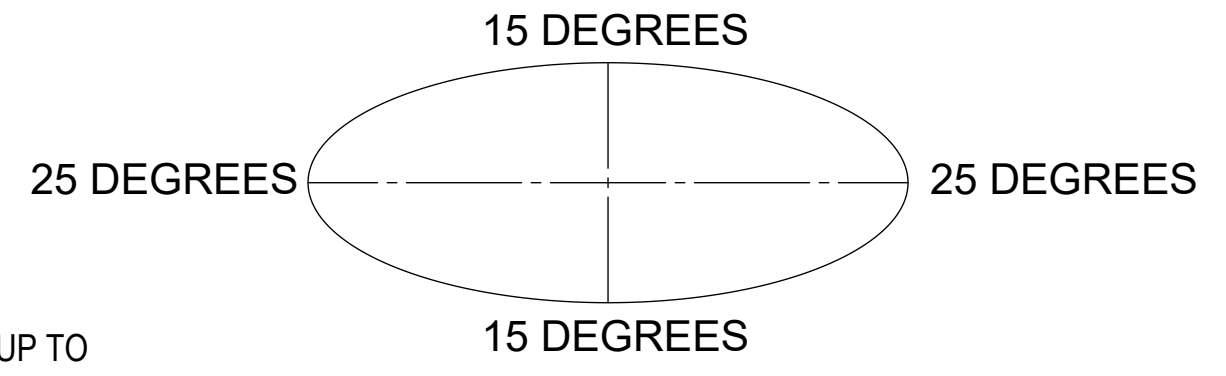

DETAIL D
SCALE 1 : 6

FOR POLES UP TO 8.0" IN DIAMETER

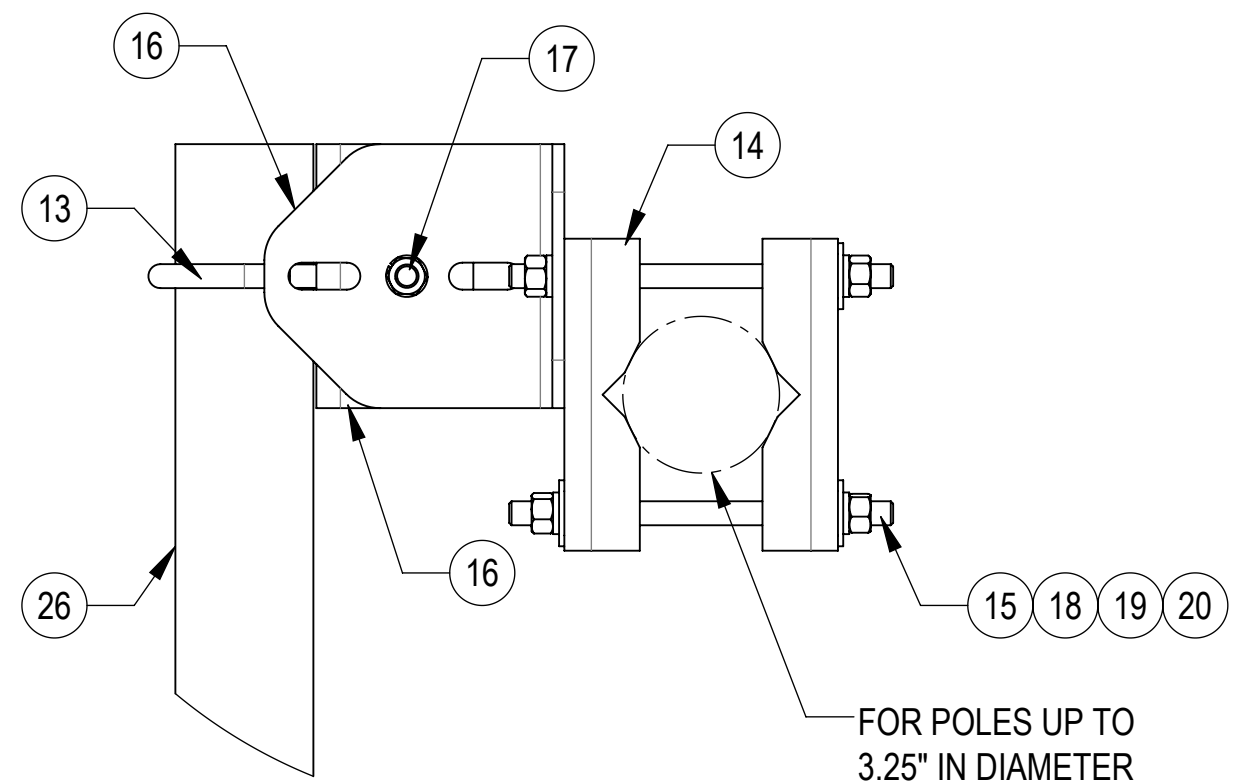

DETAIL C
SCALE 1 : 4

FOR POLES UP TO 3.25" IN DIAMETER

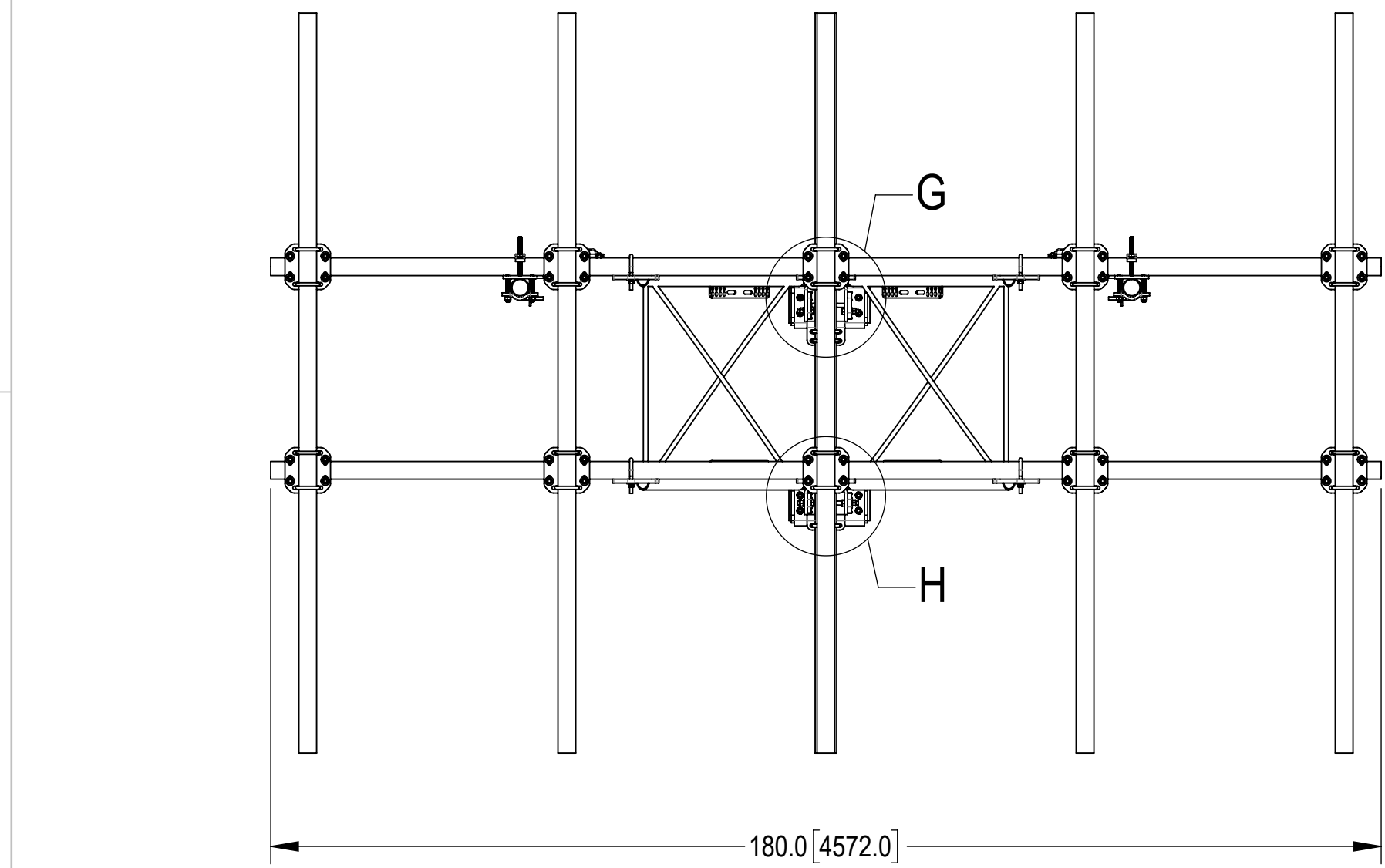

TOP
BOTTOM

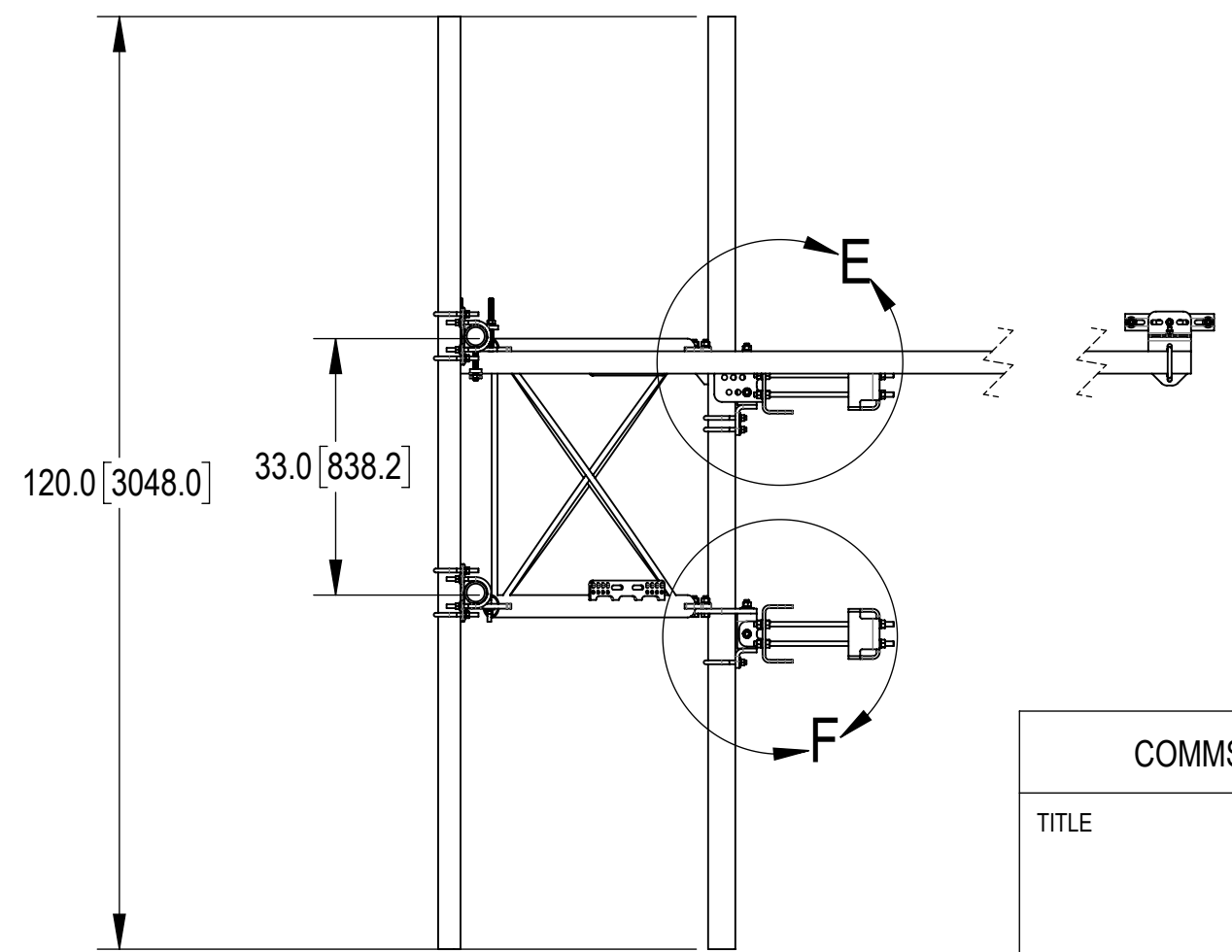

COMMSCOPE, INC. OF NORTH CAROLINA				
TITLE PG,SF,15'FP,(5)120"AP				
SIZE C	SCALE 1:22	DOCUMENT NO. SFG23RHDX-15-5-120		
		DRAWING		SHEET
		VERSION	STATUS	REVISION
		01	RE	B
				3 OF 7

4

3

2

1

4

3

2

1

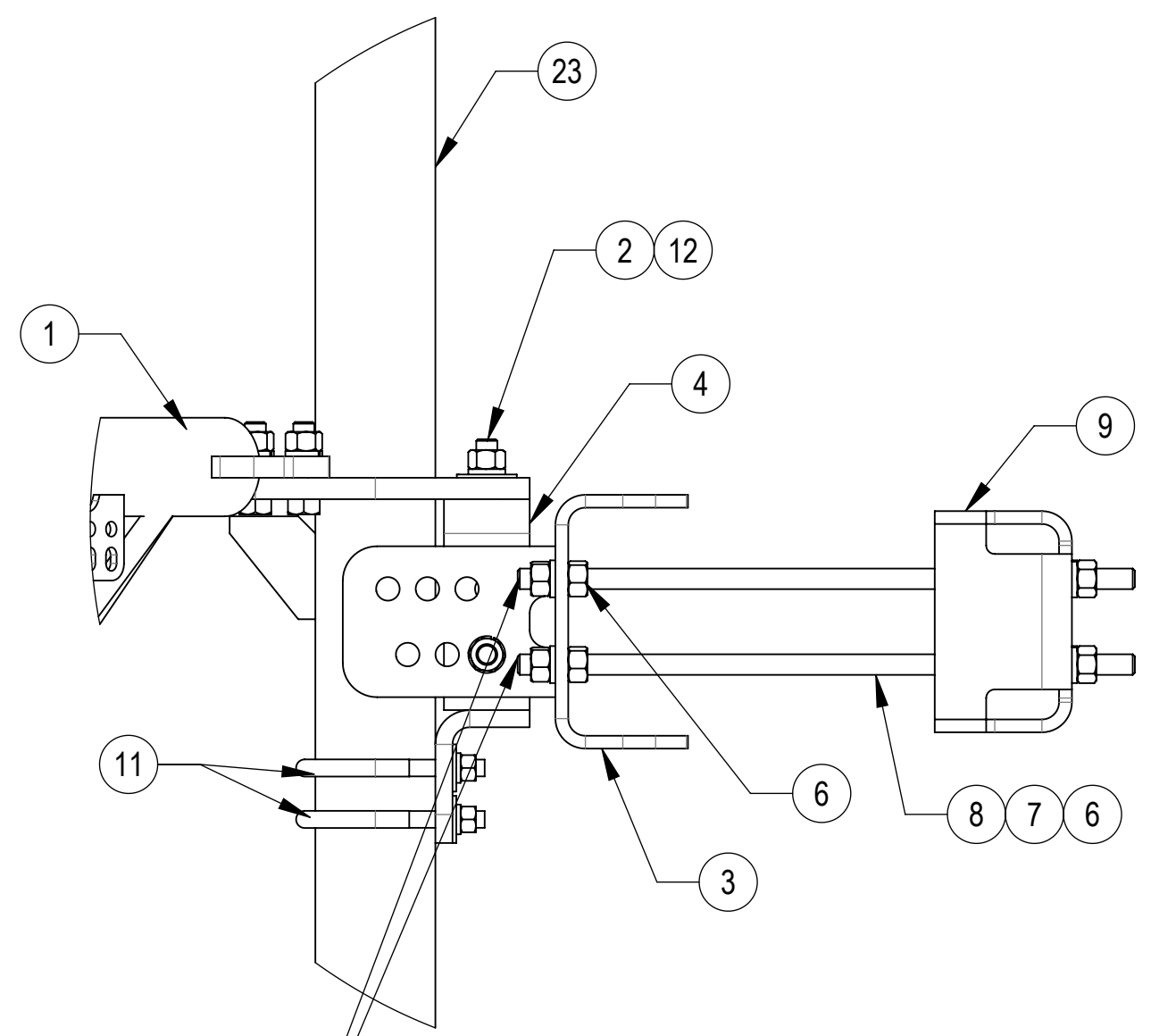

DETAIL E
SCALE 1 : 5

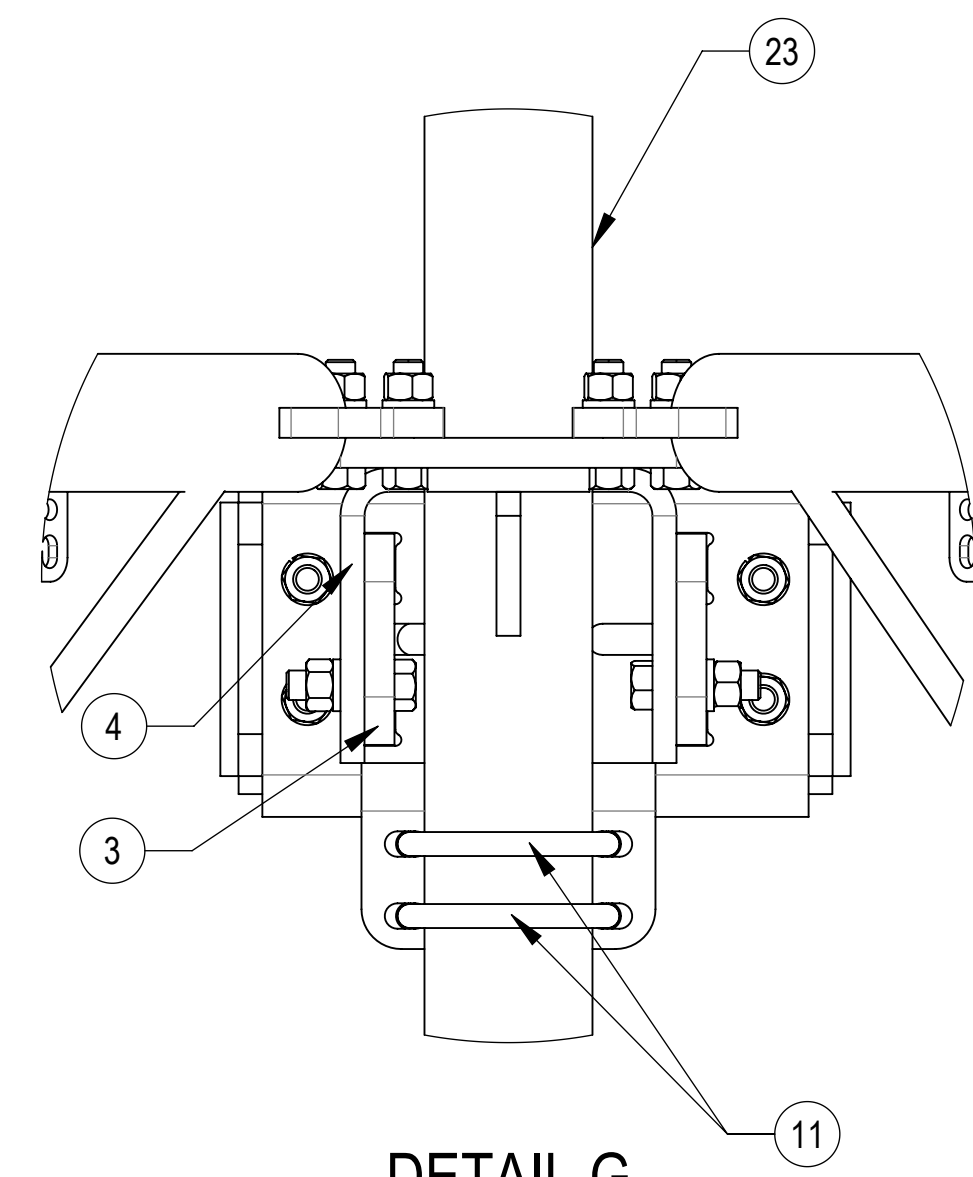

DETAIL G
SCALE 1 : 4

THE THREADED ROD CAN ONLY EXPOSE 4 TO 7
THREADS ON ONE SIDE OF THE BRACKET, WHICH IS
TO PREVENT INTERFERENCE WITH THE SIDE BOLTS

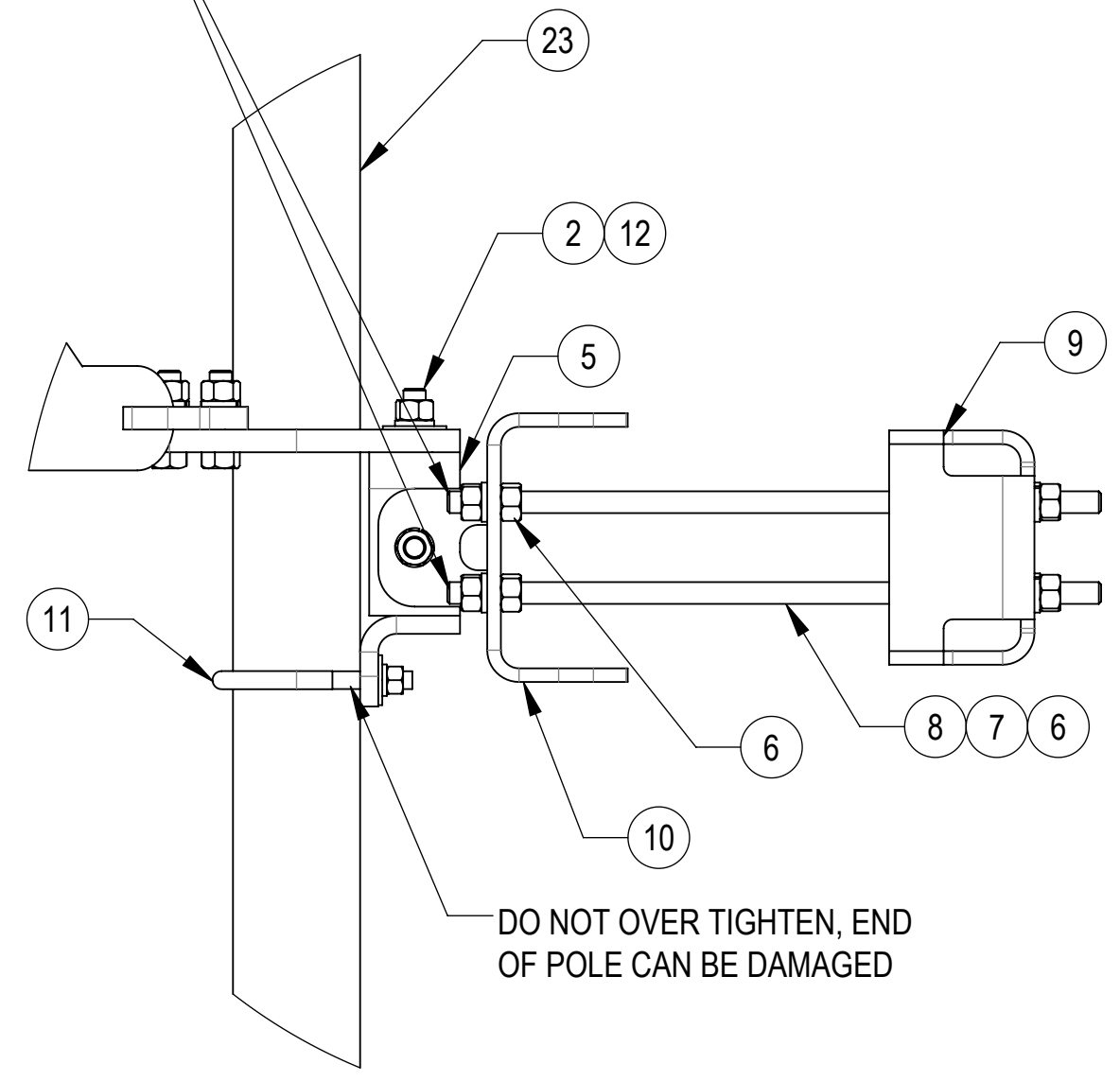

DETAIL F
SCALE 1 : 5

DO NOT OVER TIGHTEN, END
OF POLE CAN BE DAMAGED

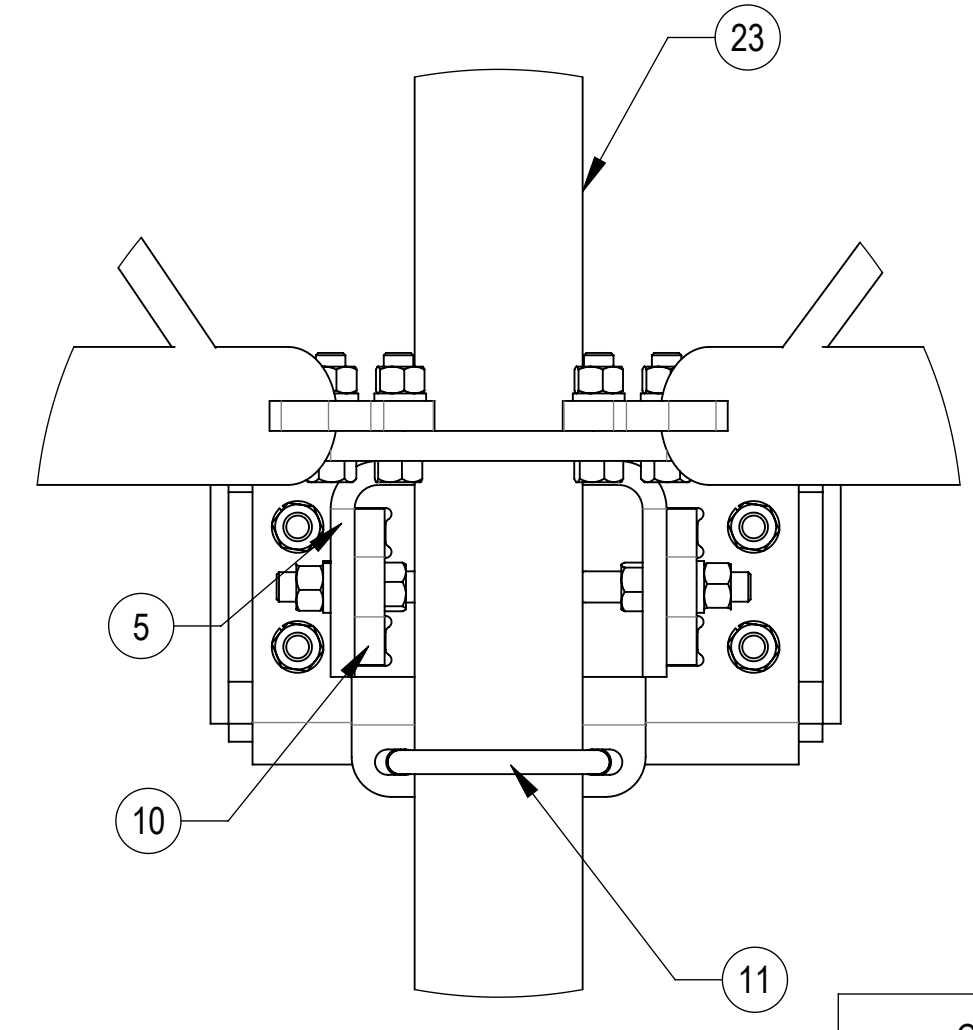

DETAIL H
SCALE 1 : 4

COMMSCOPE, INC. OF NORTH CAROLINA				
TITLE PG,SF,15'FP,(5)120"AP				
SIZE C	SCALE 1:22	DOCUMENT NO. SFG23RHDx-15-5-120		
		DRAWING		SHEET
		VERSION	STATUS	REVISION
		01	RE	B
				4 OF 7

4

3

2

1

D

D

C

C

B

B

A

A

4

3

2

1

D

D

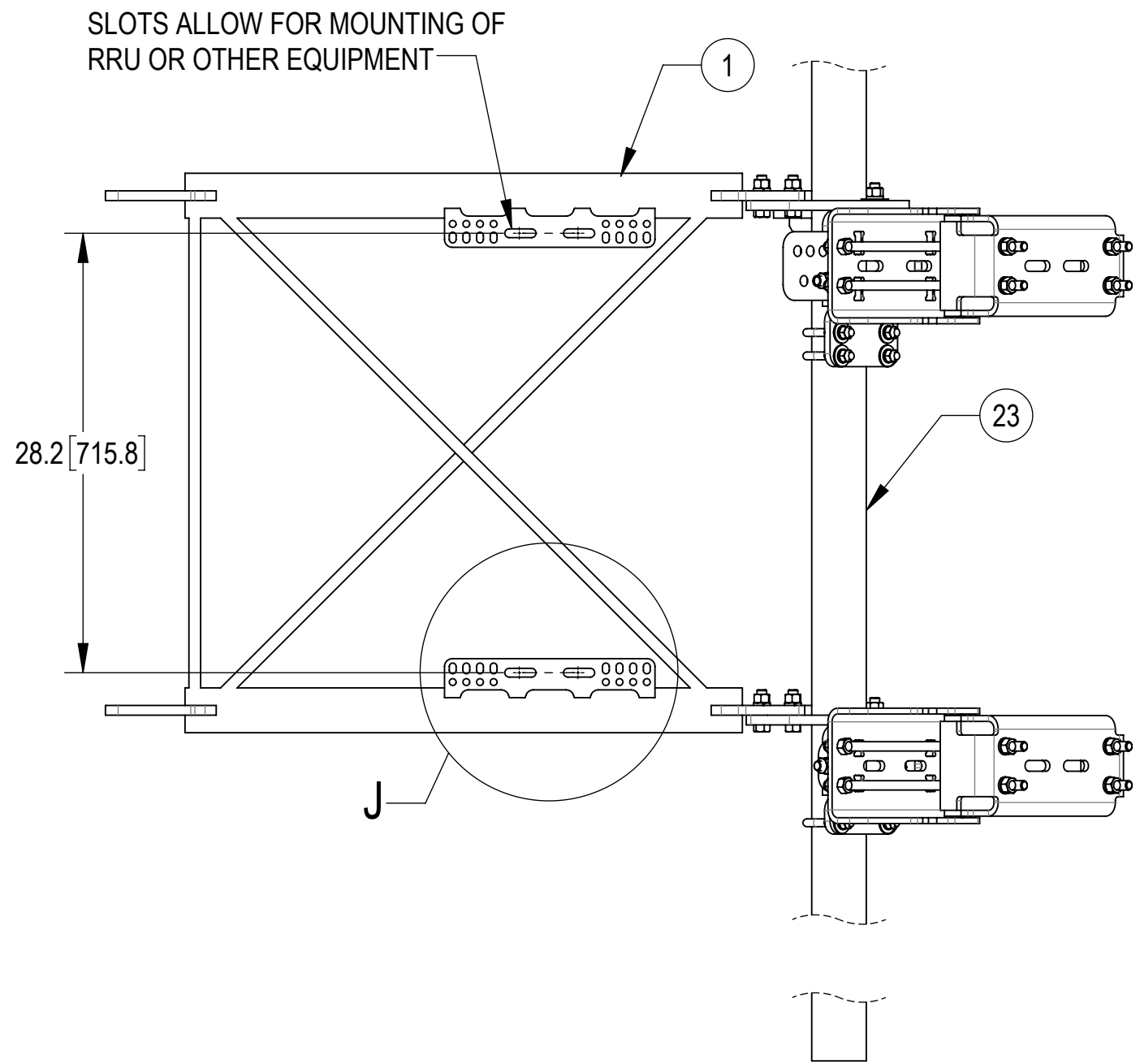

SIDE VIEW

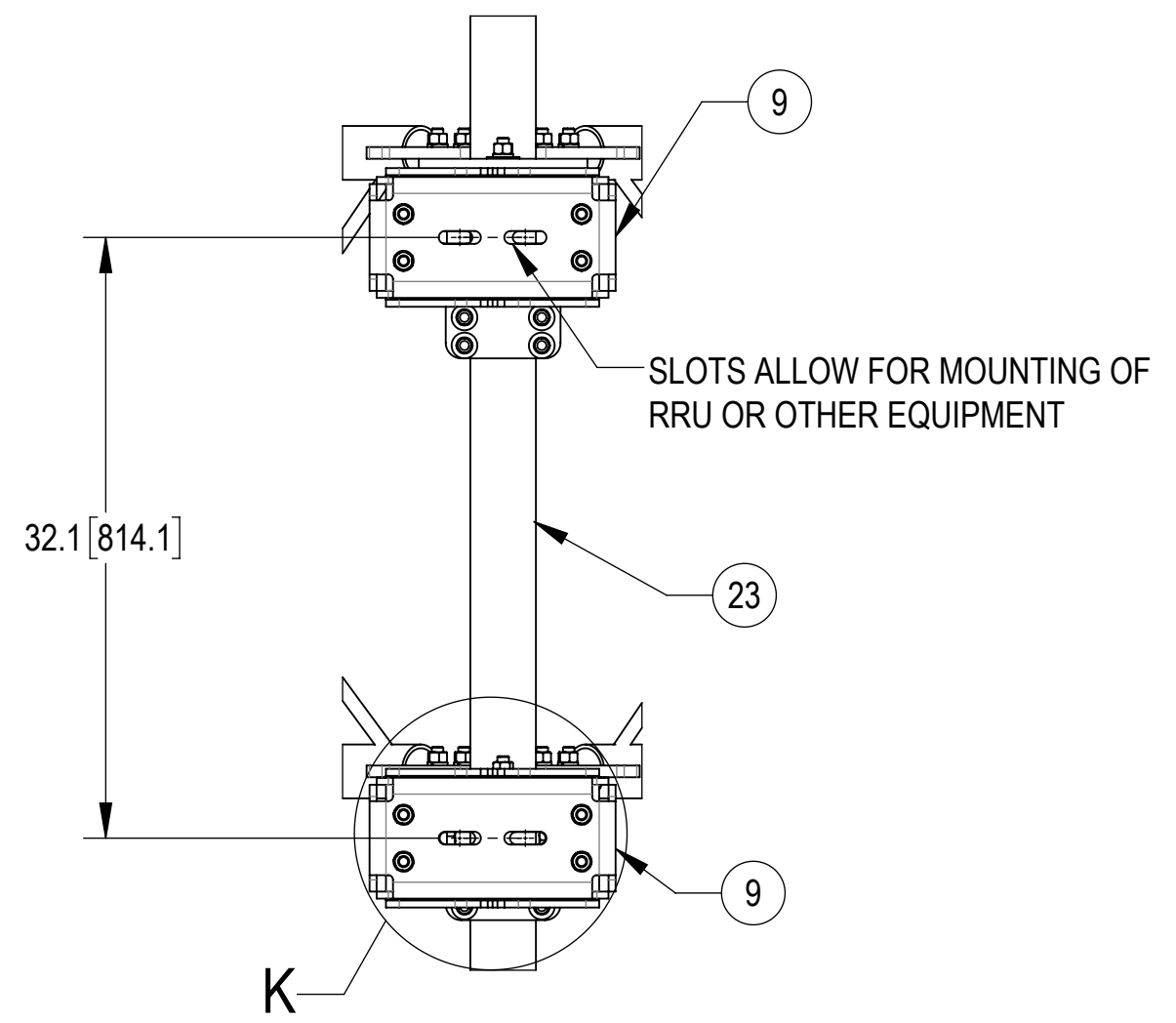

BACK CROP VIEW

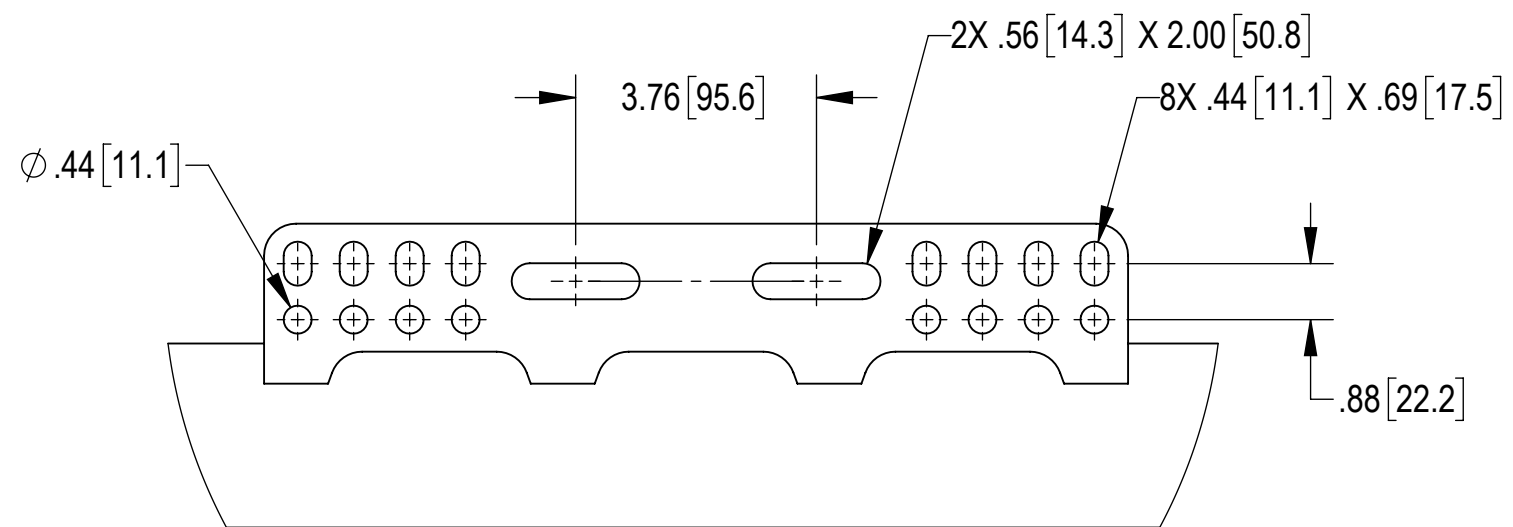

DETAIL J
SCALE 1 : 3

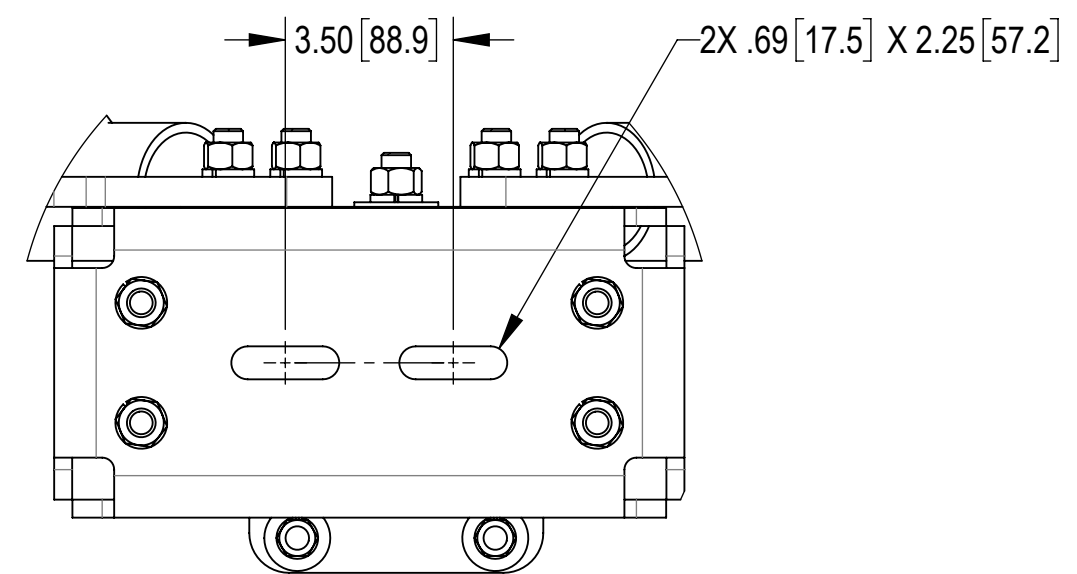

DETAIL K
SCALE 1 : 4

COMMSCOPE, INC. OF NORTH CAROLINA

TITLE
PG,SF,15'FP,(5)120"AP

SIZE C	SCALE 1:10	DOCUMENT NO. SFG23RHDX-15-5-120
------------------	----------------------	---

DRAWING			SHEET 5 OF 7
VERSION 01	STATUS RE	REVISION B	

© 2024 CommScope, Inc. Confidential

4

3

2

1

A

A

ANTENNA SPACING SHOWN

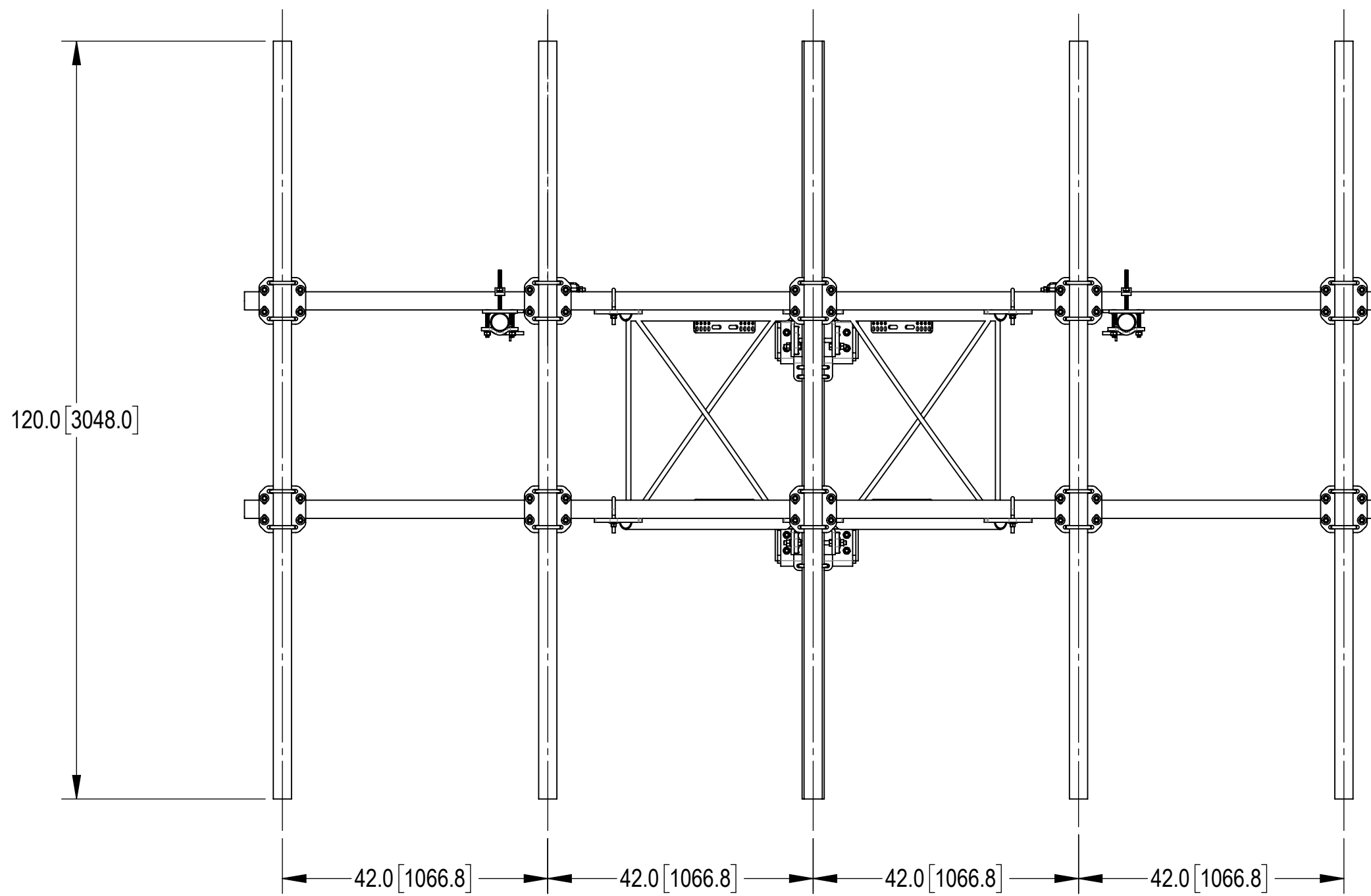
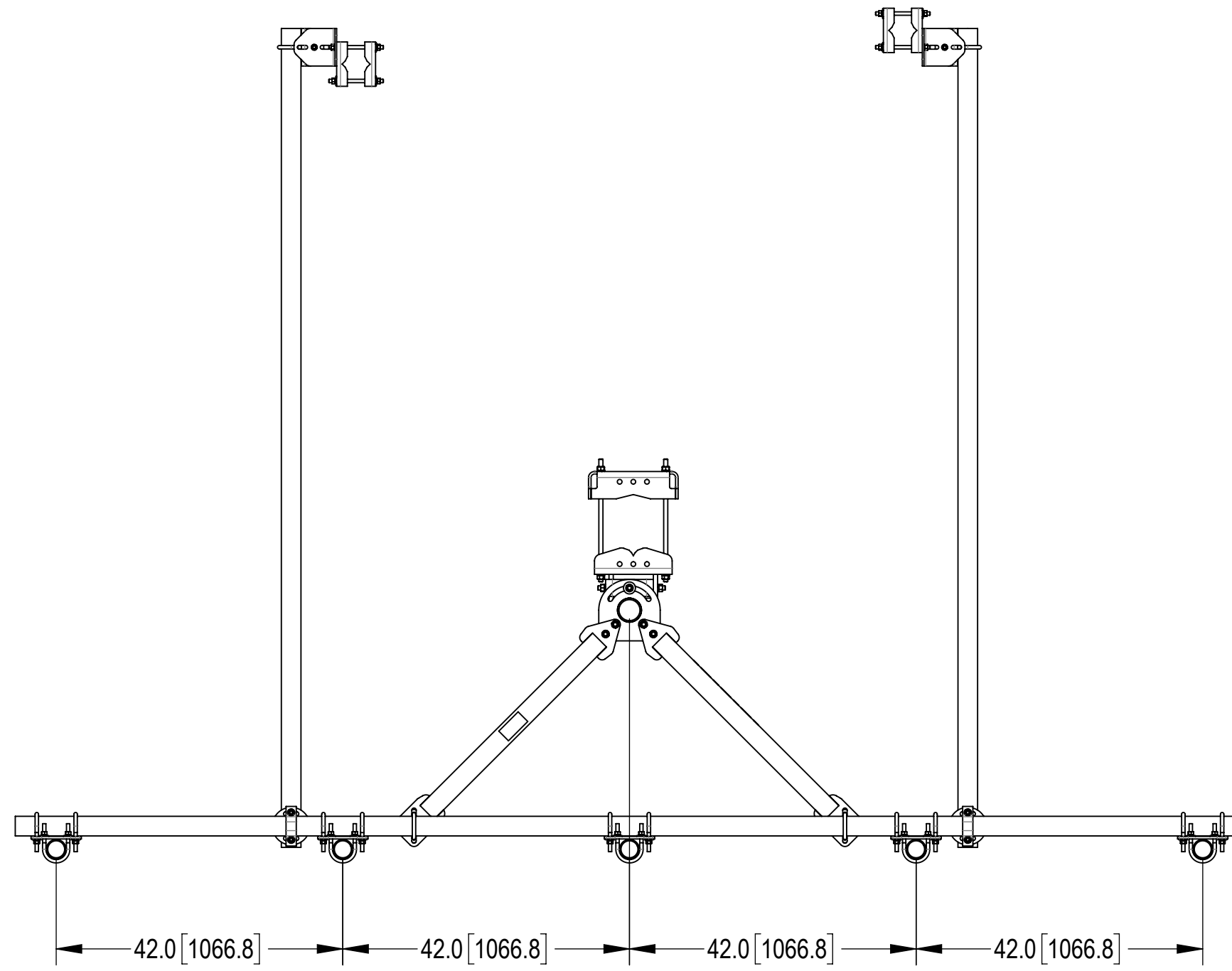

COMMSCOPE, INC. OF NORTH CAROLINA				
TITLE PG,SF,15'FP,(5)120"AP				
SIZE C	SCALE 1:20	DOCUMENT NO. SFG23RHDx-15-5-120		
		DRAWING		SHEET
		VERSION	STATUS	REVISION
		01	RE	B
				6 OF 7

ACCESSORIES ORDERED SEPARATELY:

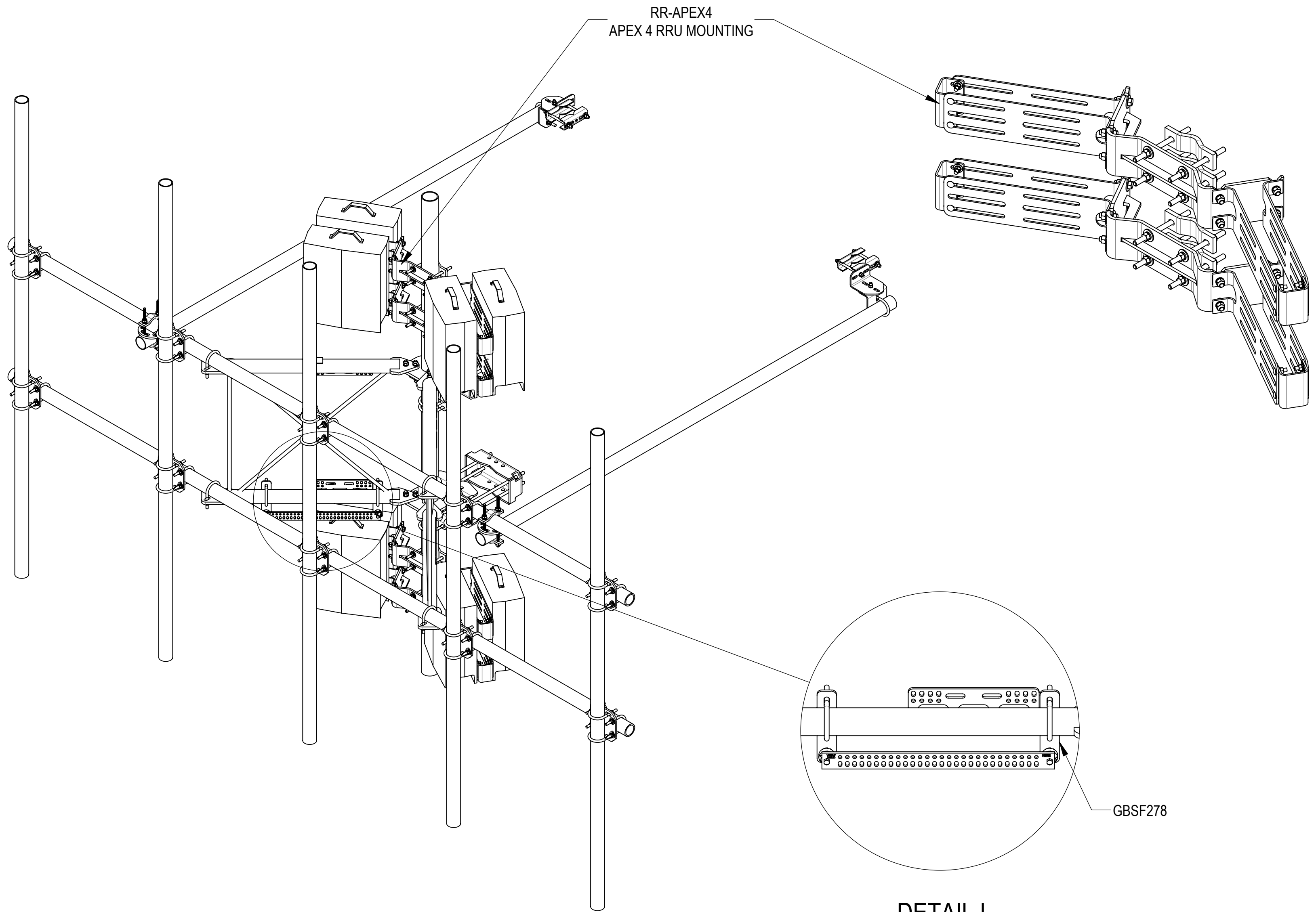

COMMSCOPE, INC. OF NORTH CAROLINA				
TITLE PG,SF,15'FP,(5)120"AP				
SIZE C	SCALE 1:14	DOCUMENT NO. SFG23RHDX-15-5-120		
		DRAWING		SHEET
		VERSION	STATUS	REVISION
		01	RE	B
				7 OF 7