

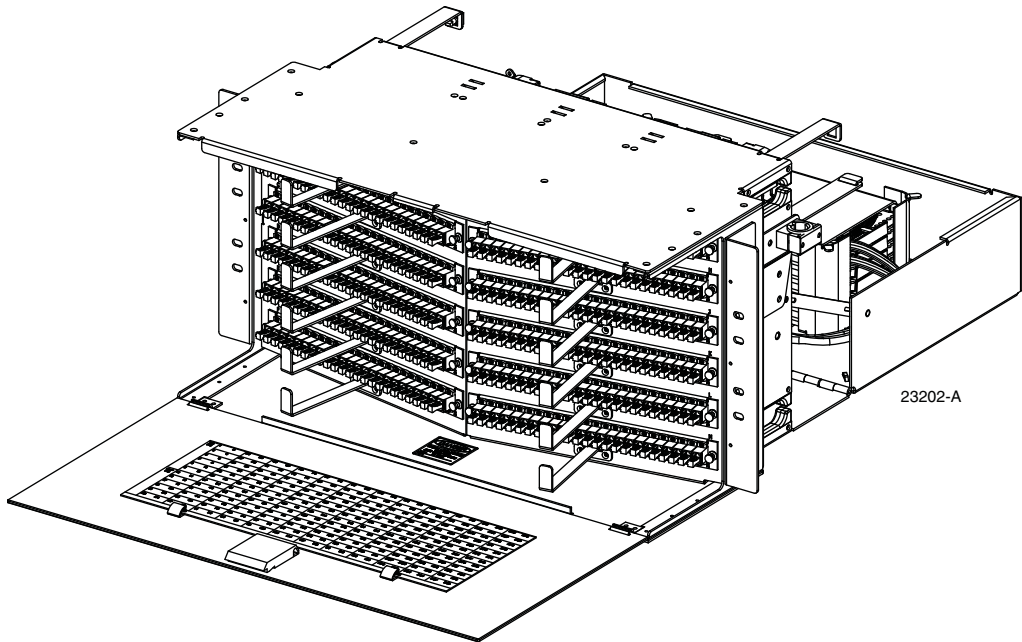

LGX-Compatible (LSX) 288-Position Termination With Splicing Module

User Manual

ADCP-93-103 • Issue 3 • November 2016



COPYRIGHT

© 2016, CommScope Inc.
All Rights Reserved

REVISION HISTORY

| ISSUE | DATE | REASON FOR CHANGE |
|-------|---------------|------------------------------|
| 1 | 7/2014 | Original. |
| 2 | Novemeber2016 | Updated to CommScope format. |

TRADEMARK INFORMATION

CommScope and CommScope (logo), are trademarks.
Telcordia is a registered trademark of Telcordia Technologies, Inc.
GORE is a registered trademark of W. L. Gore & Associates, Inc.

PATENTS INFORMATION

This product is covered by one or more U.S.patents or their foreign equivalents. For patents, see
<http://www.commscope.com/ProductPatent/ProductPatent.aspx>

DISCLAIMER OF LIABILITY

Contents herein are current as of the date of publication. CommScope reserves the right to change the contents without prior notice.
In no event shall CommScope be liable for any damages resulting from loss of data, loss of use, or loss of profits and CoommScope further disclaims any and all liability for indirect, incidental, special, consequential or other similar damages. This disclaimer of liability applies to all products, publications and services during and after the warranty period.

This publication may be verified at any time by contacting CommScopes's Support Center at
<http://www.commscope.com/SupportCenter>



TABLE OF CONTENTS

| Content | Page |
|---|------|
| About This Manual | v |
| Admonishments | v |
| General Safety Precautions | v |
| List of Acronyms and Abbreviations | vi |
| 1 DESCRIPTION | 1 |
| 1.1 General Description | 1 |
| 1.2 Product Function | 2 |
| 1.3 Main Components | 3 |
| 1.4 Dimensions | 5 |
| 1.5 Specifications | 6 |
| 2 UNPACKING THE PRODUCT | 6 |
| 3 INSTALLATION | 6 |
| 3.1 Mounting the Panel on the Frame | 6 |
| 3.2 Breaking Out a Cable | 8 |
| 3.3 Installing a Cable Clamp | 9 |
| 3.4 Cable Routing Within Panel | 10 |
| 4 PATCH CORD ROUTING | 12 |
| 4.1 Removing the Front Cover | 12 |
| 4.2 Selecting Patch Cord Length | 13 |
| 4.3 Routing Patch Cords on Front of Panel | 13 |
| 4.4 Cross-Connecting Within a Stand-Alone Bay | 14 |
| 4.5 Cross-Connecting Between Two or More Bays | 15 |
| 4.6 Interconnect Procedures | 17 |
| 5 CUSTOMER INFORMATION AND ASSISTANCE | 18 |

ABOUT THIS MANUAL

This manual describes and provides operating instructions for the LGX-Compatible (LSX) 288-Position Termination With Splicing panel, for the sake of brevity also called the “LSX-288 termination with splicing panel.”

ADMONISHMENTS

Important safety admonishments are used throughout this manual to warn of possible hazards to persons or equipment. An admonishment identifies a possible hazard and then explains what may happen if the hazard is not avoided. The admonishments — in the form of Dangers, Warnings, and Cautions — must be followed at all times. These warnings are flagged by use of the triangular alert icon (seen below) and are listed in descending order of severity of injury or damage and likelihood of occurrence.



Danger: *Danger is used to indicate the presence of a hazard that will cause severe personal injury, death, or substantial property damage if the hazard is not avoided.*



Warning: *Warning is used to indicate the presence of a hazard that can cause severe personal injury, death, or substantial property damage if the hazard is not avoided.*



Caution: *Caution is used to indicate the presence of a hazard that will or can cause minor personal injury or property damage if the hazard is not avoided.*

GENERAL SAFETY PRECAUTIONS



Warning: *Wet conditions increase the potential for receiving an electrical shock when installing or using electrically-powered equipment. To prevent electrical shock, never install or use electrical equipment in a wet location or during a lightning storm.*



Danger: *Use adequate lifting equipment when moving or installing the cabinet. Verify that the maximum lift weight rating of the equipment is sufficient to handle the weight of the cabinet.*



Danger: *Do not stand under a cabinet as it is being hoisted into position for mounting. A failure of the lifting equipment or apparatus could result in serious personal injury.*



Warning: *Before digging, check with all local utilities for the presence of buried cables or pipes. Contact with underground cables or pipes, especially electric power cables and gas service lines, could interrupt local utility service and cause serious personal injury and extensive property damage.*

LIST OF ACRONYMS AND ABBREVIATIONS

The acronyms and abbreviations used in this manual are detailed in the following list:

| | |
|--------------|--|
| AWG | American Wire Gauge |
| C | Centigrade |
| DI | Distribution Intercept |
| DSL | Digital Subscriber Line |
| DSLAM | Digital Subscriber Line Access Multiplexer |
| F | Fahrenheit |
| MON | Monitor |
| POTS | Plain Old Telephone Service |

1 DESCRIPTION

This section describes the LSX 288-position termination with splicing panel. Topics include general description, product function, main components, and dimensions and specifications

1.1 General Description

The LSX 288-position termination with splicing panel, shown in [Figure 1](#), is a 23-inch rack-mount, LGX-compatible panel that provides a splicing transition between one or more fiber optic cables and a termination bulkhead for fiber optic patch cords.

This panel has a 15-inch depth permitting splice trays to be mounted in its back compartment. The rear door swings down and locks in an open position to provide a horizontal working surface for installing splices. The panel is designed to be mounted on an LSX 18-inch deep high-density frame.

In a typical application, the panel serves as a splicing and distribution point to transition from Outside Plant (OSP) or Intra Facility Cable (IFC) to inbuilding circuits connected to with patch cords. The panel is shipped with pre-terminated, factory-installed pigtailed, either of ribbon or stranded construction. The panel may be used in either an interconnect or cross-connect configuration, and in either single mode or multimode applications.

The panel is 11 inches (27.9 cm) high. Five panels fit on a standard 7 foot (2.1 m) frame.

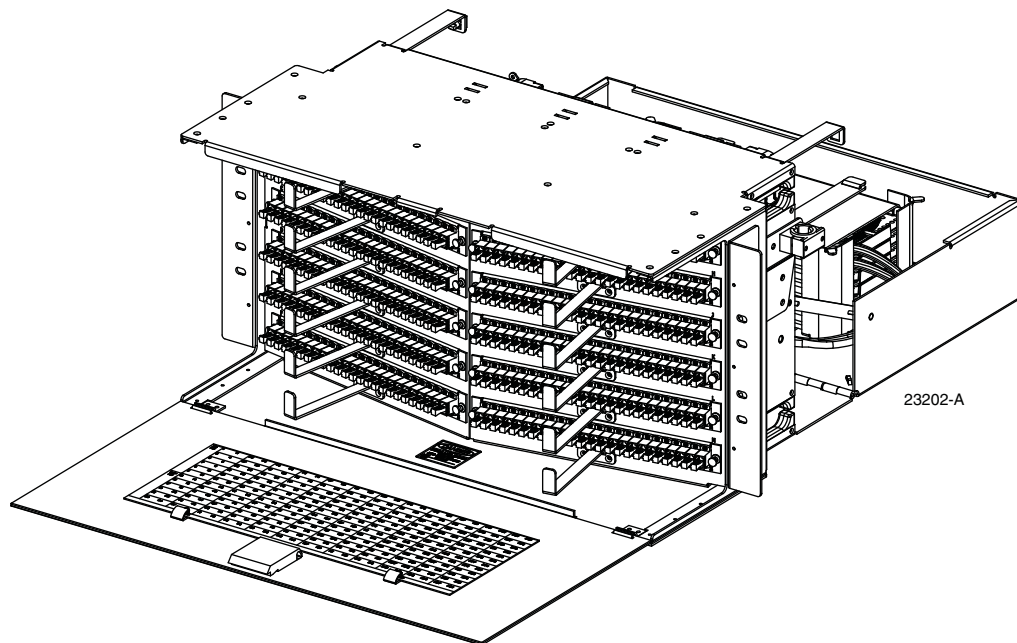

Figure 1. LSX 288-Position Termination With Splicing Panel

1.2 Product Function

Figure 2 summarizes the functional components of the LSX panel. As shown, an OSP or IFC cable is routed through the panel to the splice area access door, where the component fibers are spliced to internal ribbon pigtailed. The internal pigtailed transition to the bulkhead, located on the front of the panel. Patch cords installed from the front side of the panel provide the connection to fiber optic terminal equipment.

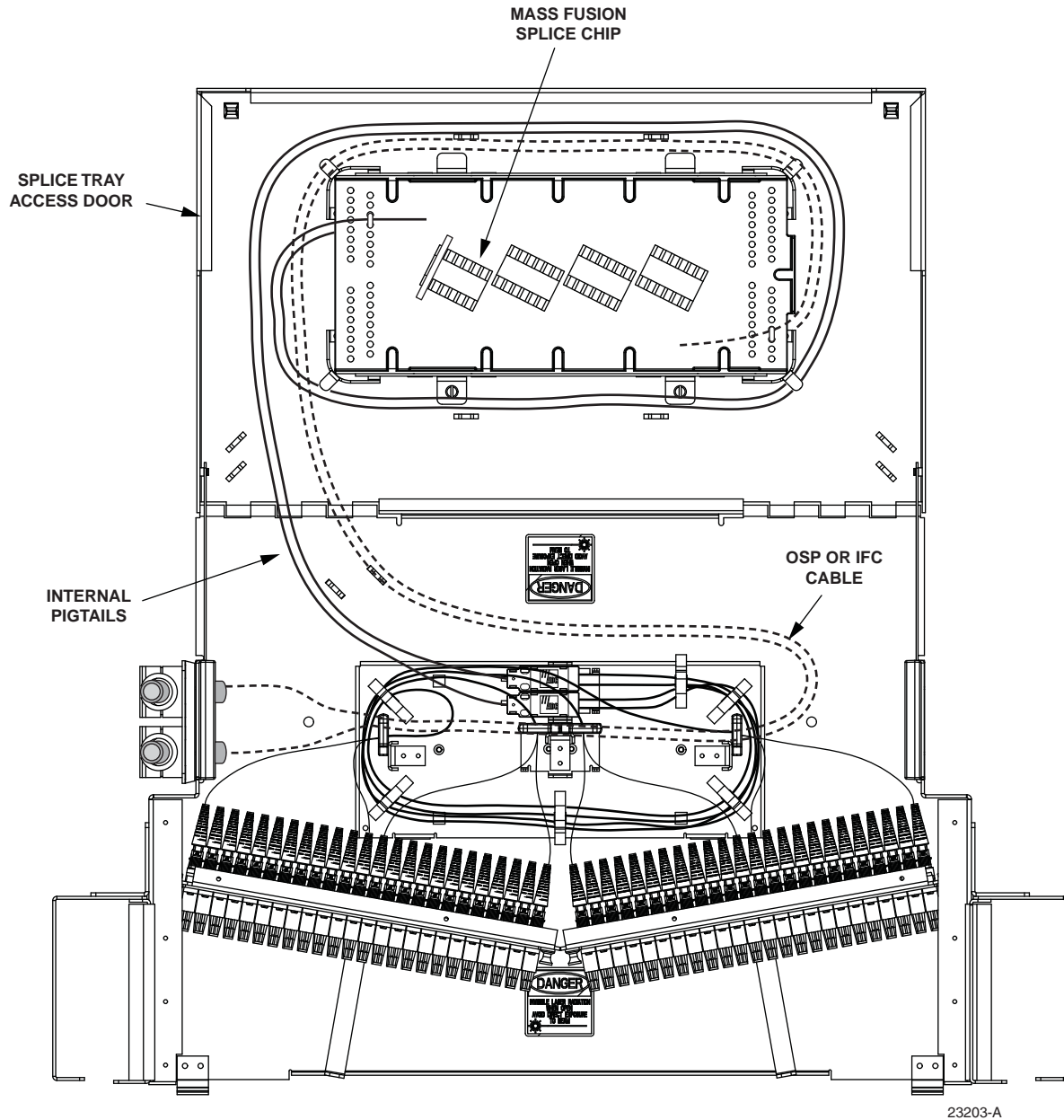

Figure 2. Functional Components of LSX Termination With Splicing Panel (Cut-Away Top View)

1.3 Main Components

Figure 3 shows the main external features of the LSX 288 Termination With Splicing Panel.

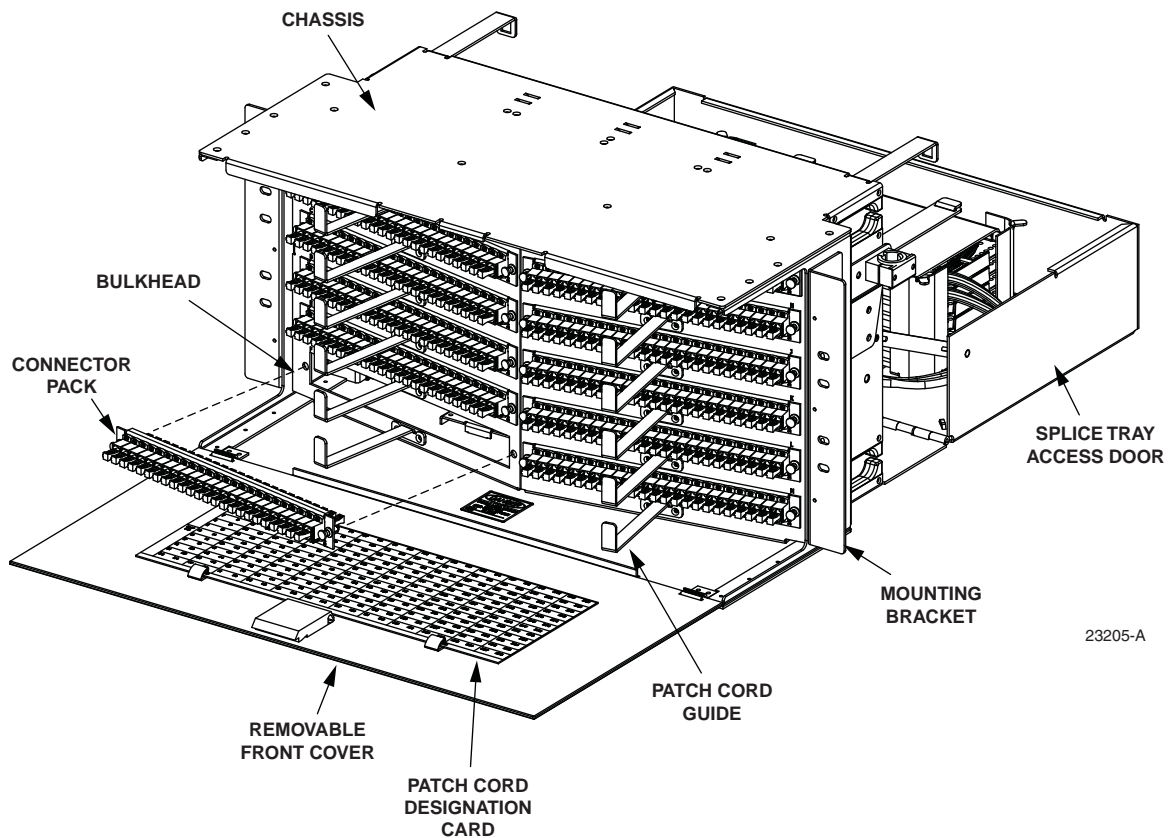

Figure 3. Main External Features (Front View)

The features shown are as follows (going from top left counterclockwise in Figure 3):

- **Chassis**—is LGX compatible. It is of solid metal construction and painted white. Five chassis may be installed on an LGX frame.
- **Bulkhead**—holds the pass-through adapters that provide the physical interface between the connector ends of the LSX internal pigtailed and patch cords installed on the front side of the bulkhead. Its angled construction facilitates installation of patch cords.
- **Connector Pack**—mounts in the bulkhead providing one row of 24 adapters/connectors for terminating patch cords. SC or LC connector types are available.
- **Removable Front Cover**—provides unimpeded access for installation of patch cords.
- **Patch Cord Designation Card**—is used to record patch cord usage.
- **Patch Cord Guides**—provide cable management in routing patch cords.
- **Mounting Bracket**—is designed for 23-inch rack mount.
- **Splice Tray Access Door**—provides access to rear splice area.

Every panel has a rear splice area such as shown in [Figure 4](#).

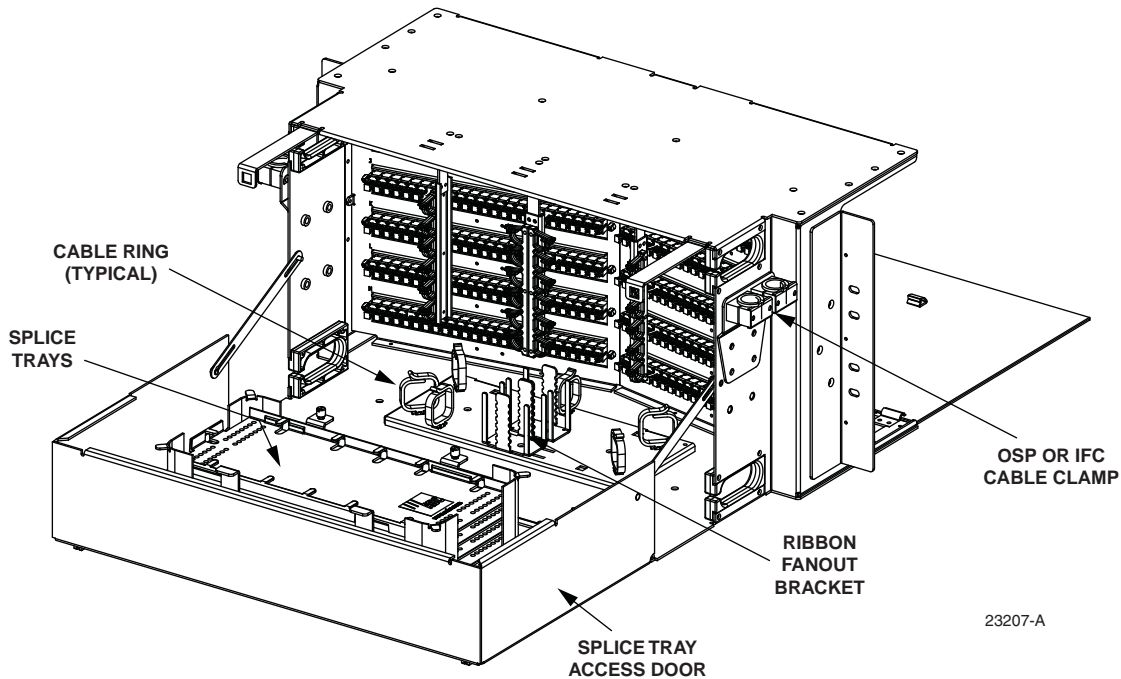

Figure 4. Main Internal Features (Rear View)

From top left counterclockwise, the main features in the rear splice area are as follows:

- **Cable Ring**—routes and secures stranded or ribbon cable on entry into splice area.
- **Splice Trays**—secure and protect splices.
- **Splice Tray Access Door**—folds down providing a horizontal splice deck.
- **Ribbon Fanout Bracket**—holds one stack of four fanout chips.
- **OSP or IFC Cable Clamp**—secures the cable to the panel.

Each panel is shipped with a cable clamp as well as vertical cable guides and cable shields (two of each, not shown). Accessories available for the panel include patch cords, heatshrink- or mass-fusion splice chips, and cable clamps (if additional clamps are needed).

1.4 Dimensions

Figure 5 shows panel dimensions.

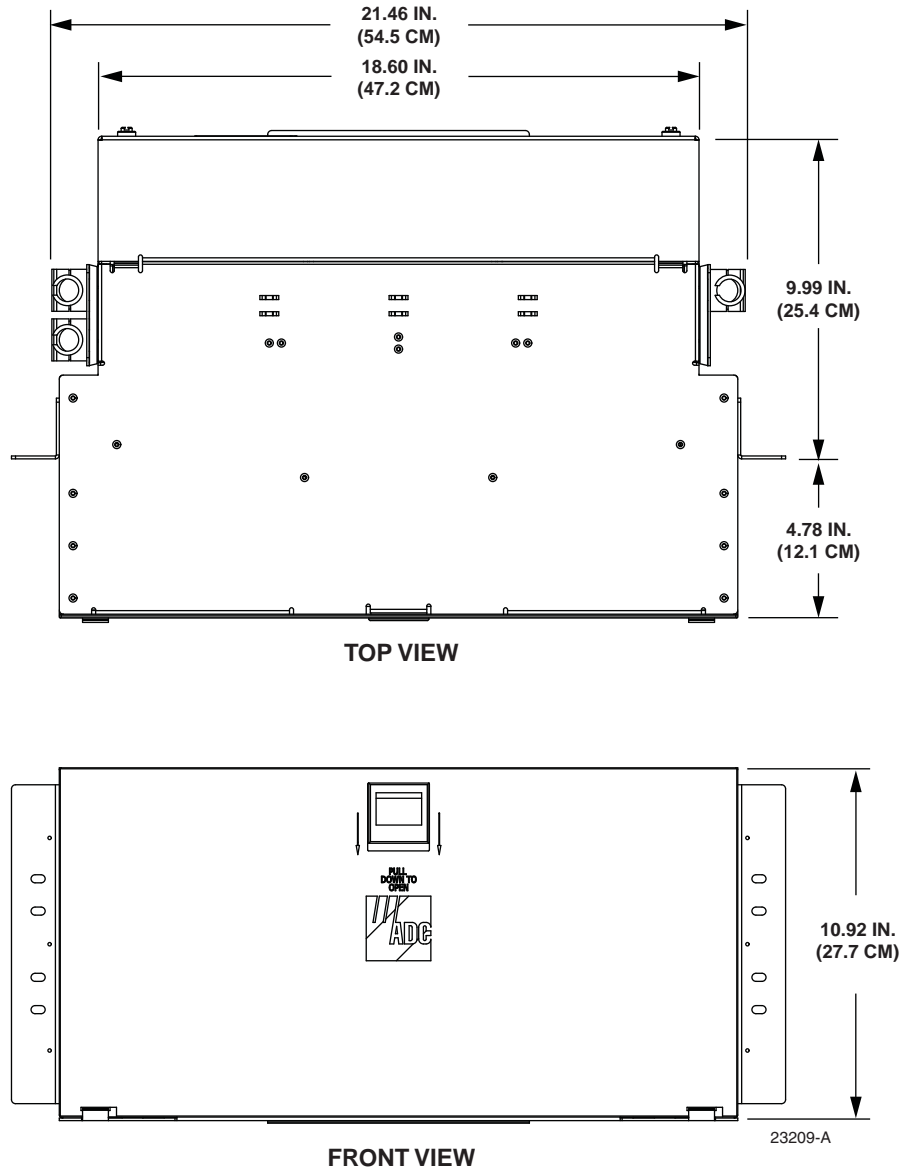

Figure 5. Panel Dimensions

1.5 Specifications

Table 1 lists specifications for the LSX combination panel.

Table 1. LSX Combination Termination/Splice panel Specifications

| ITEM | DESCRIPTION |
|------------------------|---|
| Dimensions (HxWxD) | 15 x 23 x 15 in. (27.9 x 58.4 x 38.1cm) |
| Rack Mount | Mounts in 23-inch rack |
| Weight (unloaded) | 10 pounds (4.5 kg) |
| Terminations | 288 terminations |
| Connector type | SC or LC |
| Pre-installed pigtails | Ribbon or stranded IFC |
| Splice tray capacity | Six splice trays |
| Splice chips | Mass fusion or heatshrink fusion |

2 UNPACKING THE PRODUCT

Unpack and inspect the LSX combination panel as follows:

1. Inspect the exterior of the shipping container for evidence of rough handling that may have damaged the contents of the container.
 2. If damage is detected or if parts are missing, file a claim with the commercial carrier and then notify ADC Customer Service. Save the damaged carton for inspection by the carrier.
- **Note:** For information on how to contact ADC, if needed, see [Section 5 on Page 18](#).
3. Save the shipping container for use in case the equipment requires shipment at a future date.

3 INSTALLATION

The main steps in installing an LSX panel are: mounting the panel on the frame, breaking out the cable to be spliced within the panel, installing the cable on the outside of the panel using the ADC-provided cable clamp, and routing the cable within the panel from the cable clamp to the splice deck. For instructions, refer to the following subsections.

3.1 Mounting the Panel on the Frame

Install the panel from the front side of the rack, using the following procedure. Refer to [Figure 6](#).

- **Note:** Because of its extra depth due to its rear splice area, the LSX panel should be installed on an LGX fiber distribution frame with a depth of at least 15 inches (38.1 cm).

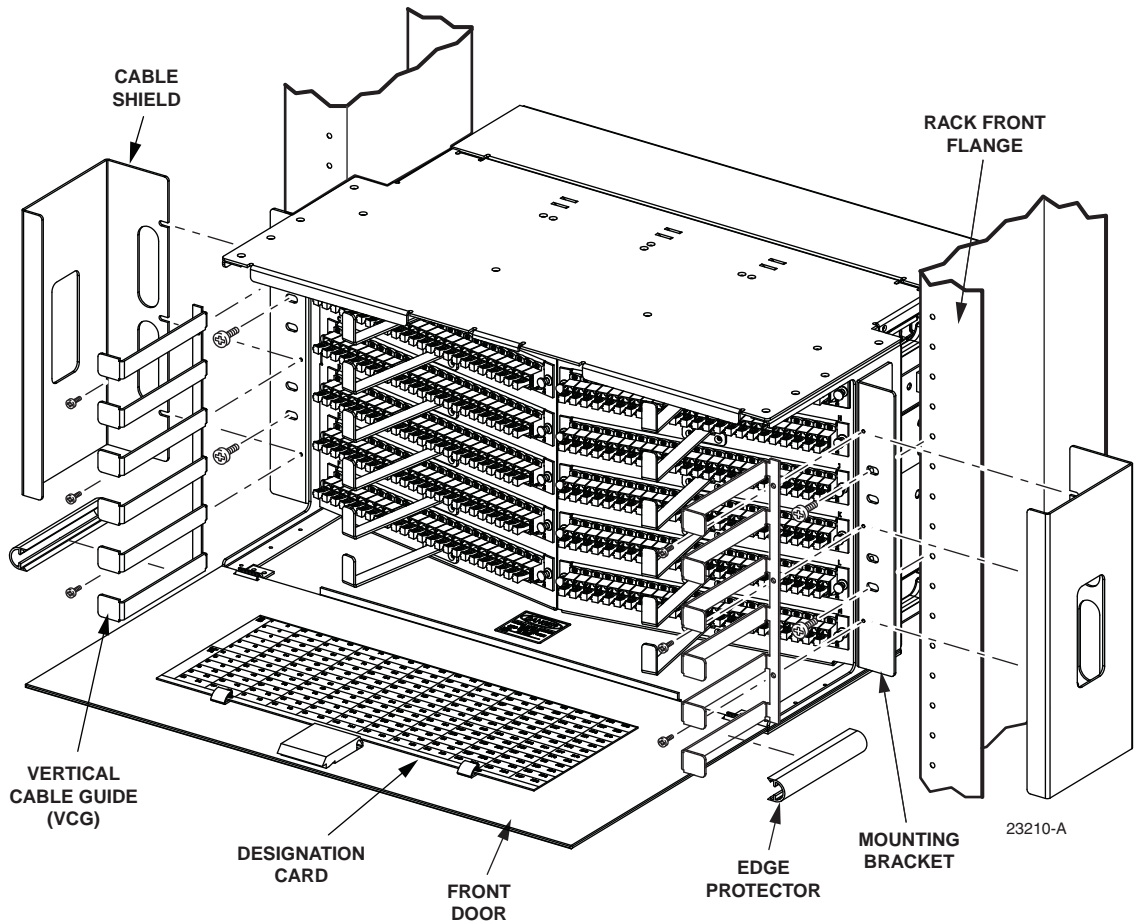

Figure 6. Installing the Panel

1. Locate the two vertical cable guides (VCGs) and two cable shields among the separately packaged shipped items.
- **Note:** The VCGs have a left or right orientation and only fit properly on the correct side of the panel.
2. Install the VCGs and cable shields using the three small screws provided to secure them to the three small holes in the mounting bracket.
 3. Determine the mounting location for the panel.
 4. Secure the mounting brackets to the rack front flange using eight #12-24 mounting screws.

3.2 Breaking Out a Cable

If preparing a cable for installation, break out and prepare the cable corresponding to [Figure 7](#) for ribbon cable and [Figure 8](#) for stranded cable. Kits are available from ADC.

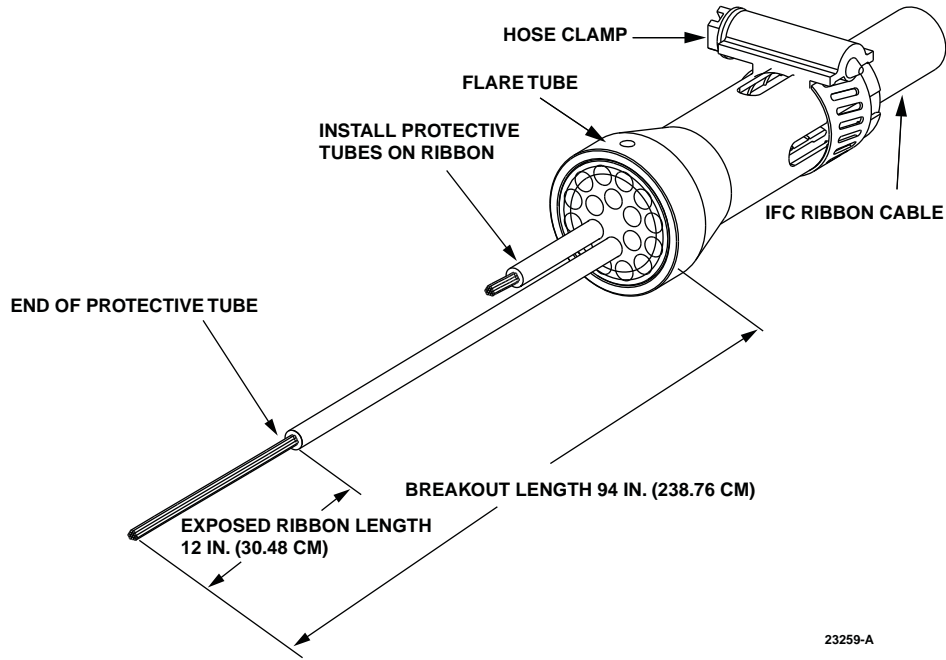

Figure 7. Recommended Breakout Dimensions for Ribbon Cable

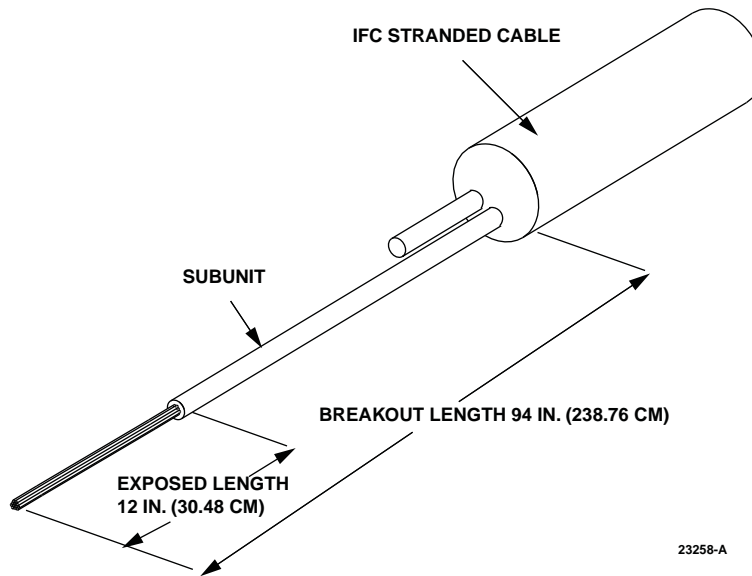

Figure 8. Recommended Breakout Dimensions for Ribbon Cable

3.3 Installing a Cable Clamp

Every panel is shipped with two cable clamps. The clamps can be used to secure a cable to the chassis. Route the cable in from above or below the panel and secure the cable in the cable clamp at the cable breakout point. To install a cable clamp, use the following procedure. Refer to [Figure 9](#).

► **Note:** [Figure 9](#) shows the cable clamp bracket positioned for cable routing from above the panel. For cable routing from below the panel, turn the cable clamp bracket upside down compared to how it is shown in the figure and use the mounting holes designated in the figure as “for under floor cable entry.”

1. Install the cable clamp bracket on the clamp mount plate using two #12-24 screws. Be sure to position the cable clamp bracket corresponding to the note above.

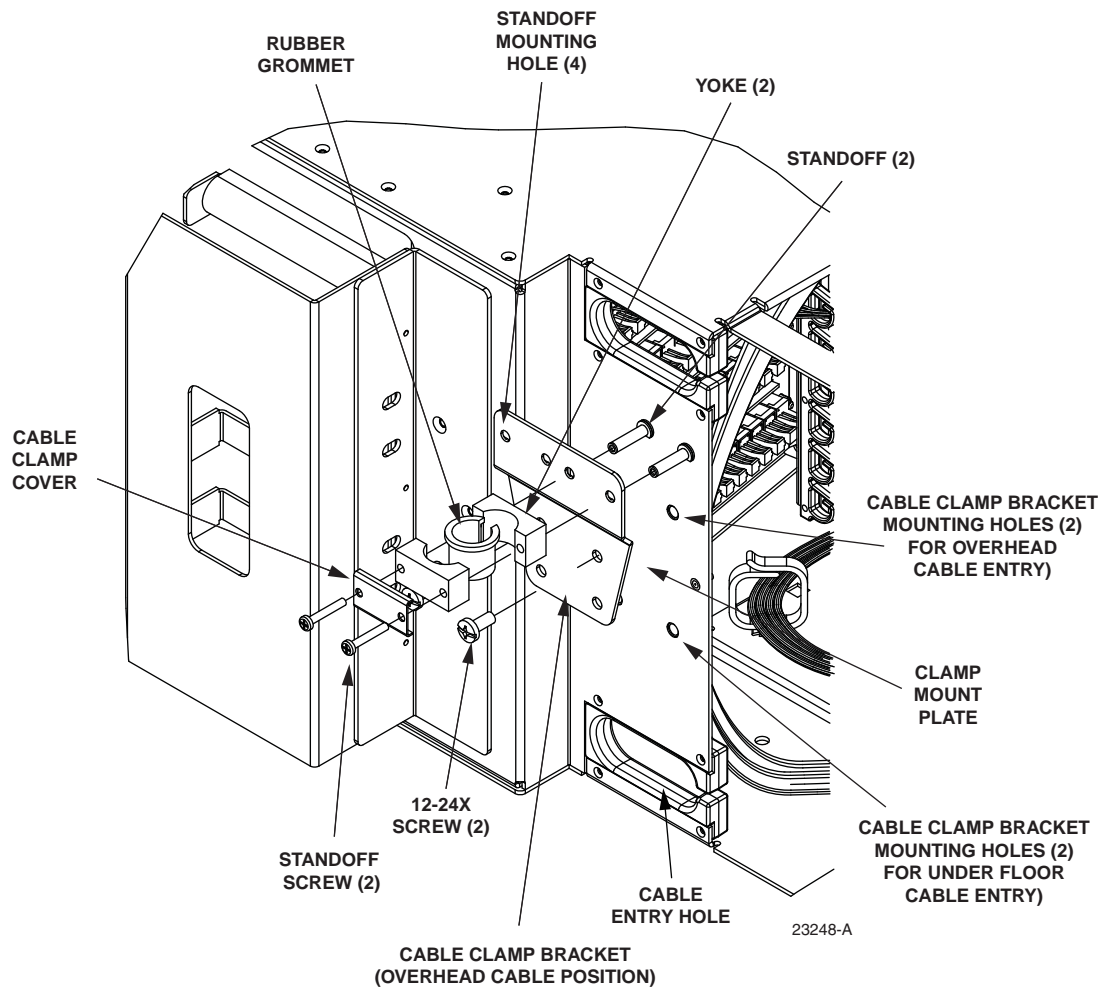

Figure 9. Installing a Cable Clamp

2. Place the two standoffs in the standoff mounting holes in the cable clamp bracket.
- ▶ **Note:** There are four standoff mounting holes. Either the two left holes or two right holes can be used together, not the two in the middle. Do not mount two cables side by side.
3. Four rubber yokes and two grommets are provided with the cable clamp kit for securing the cable to the panel. Select the grommet that, when fitted on the cable, as shown in [Figure 10](#), provides the gap width shown.

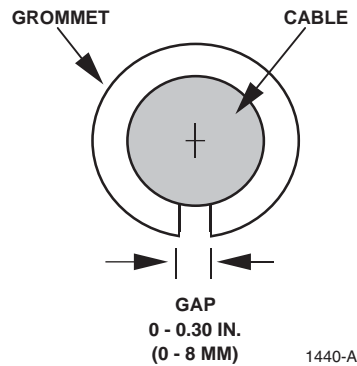

Figure 10. Grommet Selection

4. Open the splice area access door on the rear of the panel and direct the broken out section of the cable through the cable entry hole into the rear storage area of the panel. Allow the cable to remain in that position for later routing within the rear storage area.
5. Working on the outside of the panel, where the cable bracket was installed, stack the cable clamp components on the standoffs, as shown in [Figure 9](#), with the cable secured within the rubber grommet. Position the cable so that the breakout point occurs just beyond the rubber grommet.
6. Secure the cable clamp components to the standoffs using standoff screws, as shown in [Figure 9](#).

3.4 Cable Routing Within Panel

Use the following procedure to route the cable within the panel.

1. Route the cable from the entry hole horizontally across the top of the panel and then down to the splice tray access door as shown in [Figure 11](#) (top entry) and [Figure 12](#) (bottom entry). Secure the cable to the top of the panel using curleyloks at the tie-down points shown in the figures.
2. Loop the cable clockwise around the splice tray as shown in [Figure 13](#).
3. Tie down the cable at the point where the exposed ribbon cable emerges from the protective tube per the breakout dimensions provided in [Topic 3.2](#).

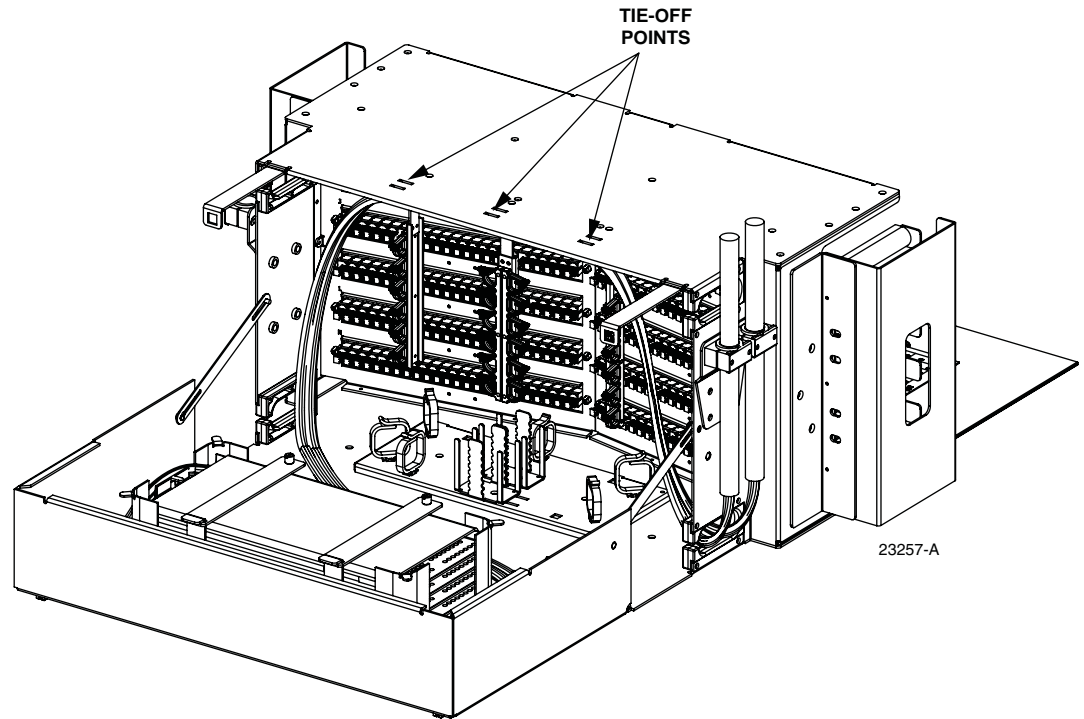

Figure 11. Cable Entry From Top

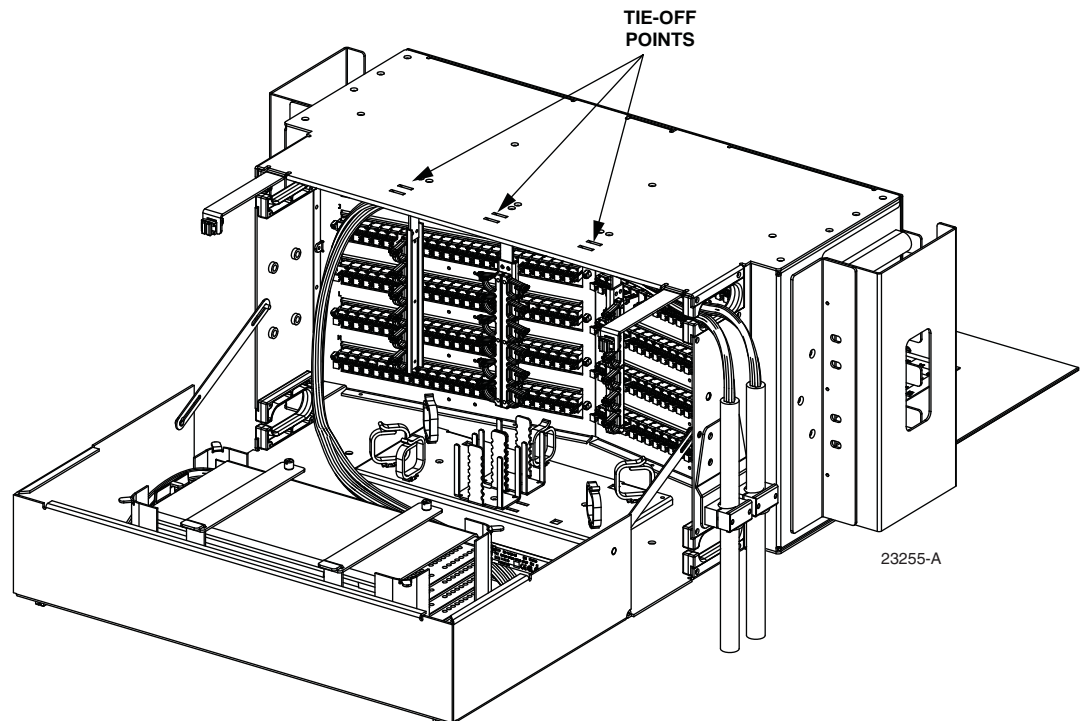

Figure 12. Cable Entry From Bottom

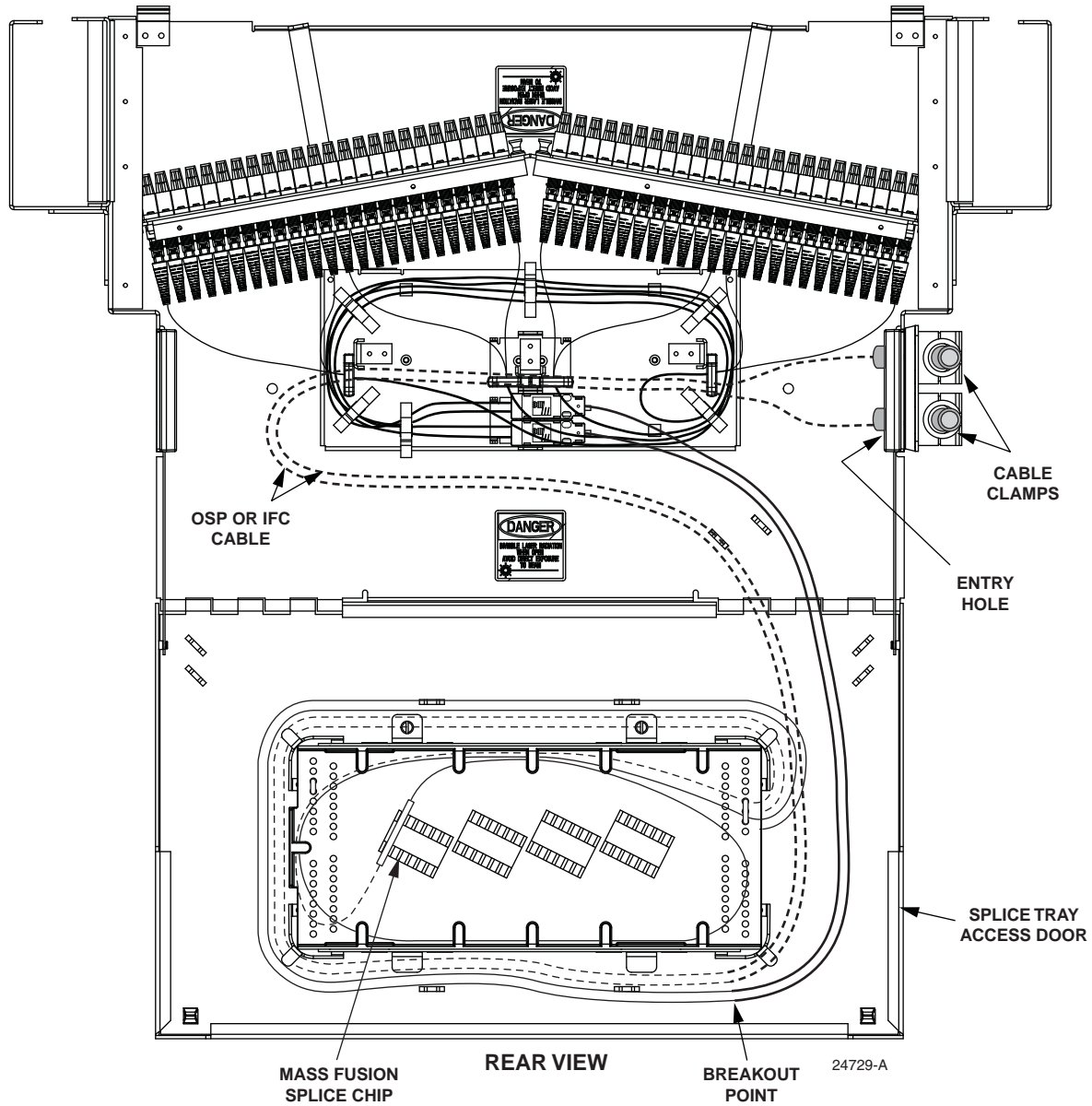

Figure 13. Cable Routing

4 PATCH CORD ROUTING

4.1 Removing the Front Cover

The front cover of the chassis may be removed to provide easier access for installation of patch cords. To remove the cover, lift it straight out of the hinges. To replace a cover, position the hinge edge of the cover on the hinges and press inward to push the edge into the hinges.

4.2 Selecting Patch Cord Length

ADC recommends a maximum of four bays per lineup with five panels per bay for a maximum of 5,670 terminations per lineup. For patch cord length, refer to [Table 2](#).

Table 2. Recommended Patch Cord Length

| NUMBER OF BAYS | APPROXIMATE PATCH CORD LENGTH | NUMBER OF BAYS | APPROXIMATE PATCH CORD LENGTH |
|----------------|-------------------------------|----------------|-------------------------------|
| 1 | 5 m (16.4 ft.) | 3 | 6 m (19.7 ft.) |
| 2 | 6 m (19.7 ft.) | 4 | 7 m (23 ft.) |

4.3 Routing Patch Cords on Front of Panel



Danger: Infrared radiation is invisible and can seriously damage the retina of the eye. Do not look into the ends of any optical fiber. Do not look directly into the optical adapters of the adapter packs. Exposure to invisible laser radiation may result. An optical power meter should be used to verify active fibers. A protective cap **MUST** be immediately placed over any radiating adapter or optical fiber connector to avoid the potential of dangerous amounts of radiation exposure. This practice also prevents dirt particles from entering the adapter or connector.

Whenever patch cords are installed, route them down and to the side, as shown in [Figure 14](#).

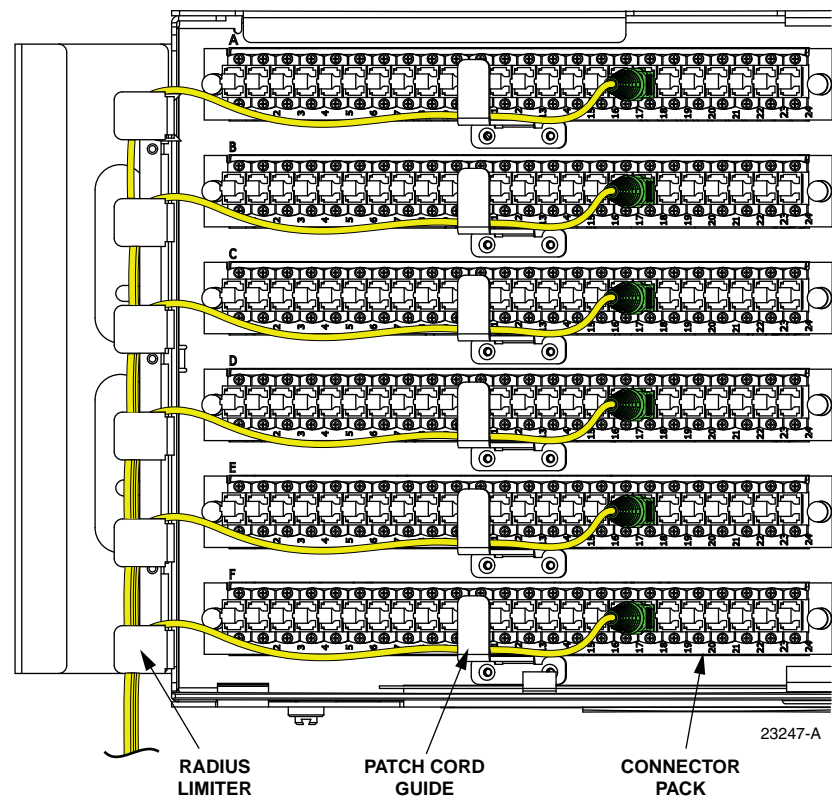

Figure 14. Correct Routing of Patch Cords

4.4 Cross-Connecting Within a Stand-Alone Bay

Cross-connecting within a stand-alone bay may be required when facility and equipment terminations are intermixed. Most cross-connection routing within a stand-alone bay should be done with 5 meter (16.5 ft.) patch cords. Shorter 3 meter (9.9 ft.) patch cords can be used when both ends are terminated in the top half of the bay.

Use the following procedure to route patch cords on a stand-alone bay.

1. Determine whether the ports to be connected are on the same side or opposite sides of the bay, as shown in Figure 15.
2. Select from the routing paths shown and route and connect the patch cord.
3. Loop up any cable slack around the appropriate spool on the vertical trough.

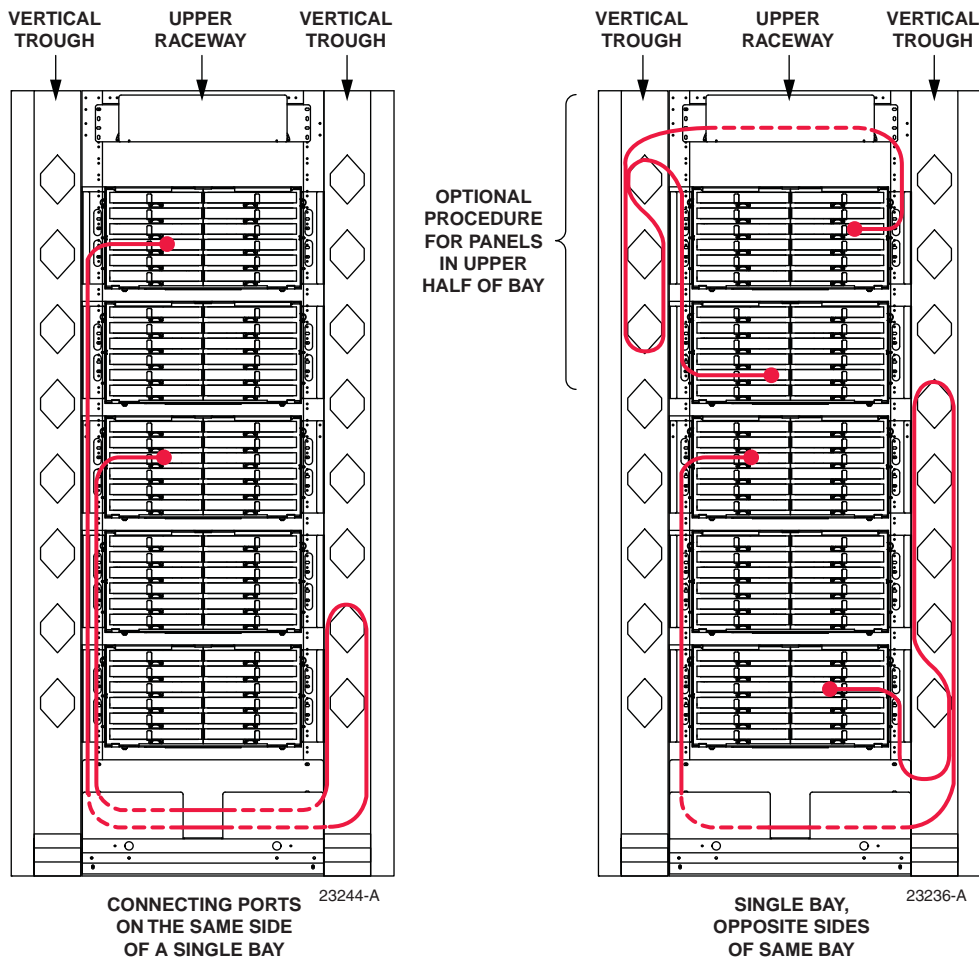

Figure 15. Routing Patch Cords on a Stand-Alone Bay

4.5 Cross-Connecting Between Two or More Bays

Most cross-connection routing between adjacent racks should be done with 6 meter (19.8 ft.) patch cords. Shorter 4 meter (13.2 ft.) patch cords can be used when both ends are terminated in the top left of the frame. To route patch cords between adjacent bays, use the following procedure.

1. Terminate one end of the patch cord on the originating LSX panel and bay, then route the patch cord left or right to the nearest vertical trough.
2. At the destination panel and bay, terminate the opposite end of the patch cord, then route the patch cord left or right to the nearest vertical trough.
3. Allow the patch cord to droop down into the lower raceway.
4. Based on the termination and ending points for the patch cord, select from the routing paths shown in [Figure 16](#) on this page or [Figure 17](#) on the next page.
5. Arrange the patch cord using the lower raceway and the indicated vertical trough to take up the cable slack around the appropriate spool in the vertical trough.

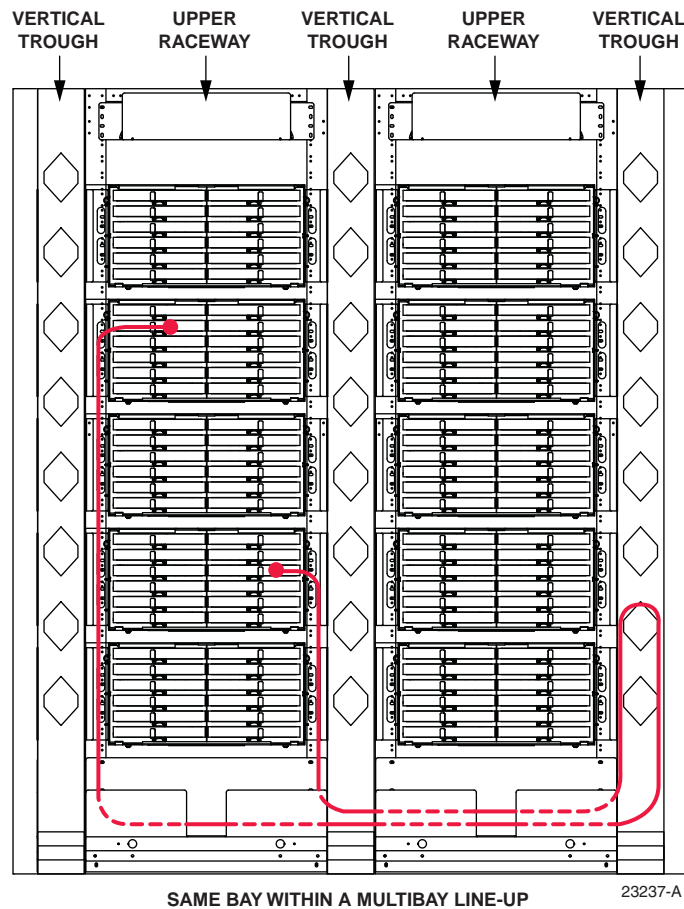

Figure 16. Routing Patch Cords Between Adjacent Bays

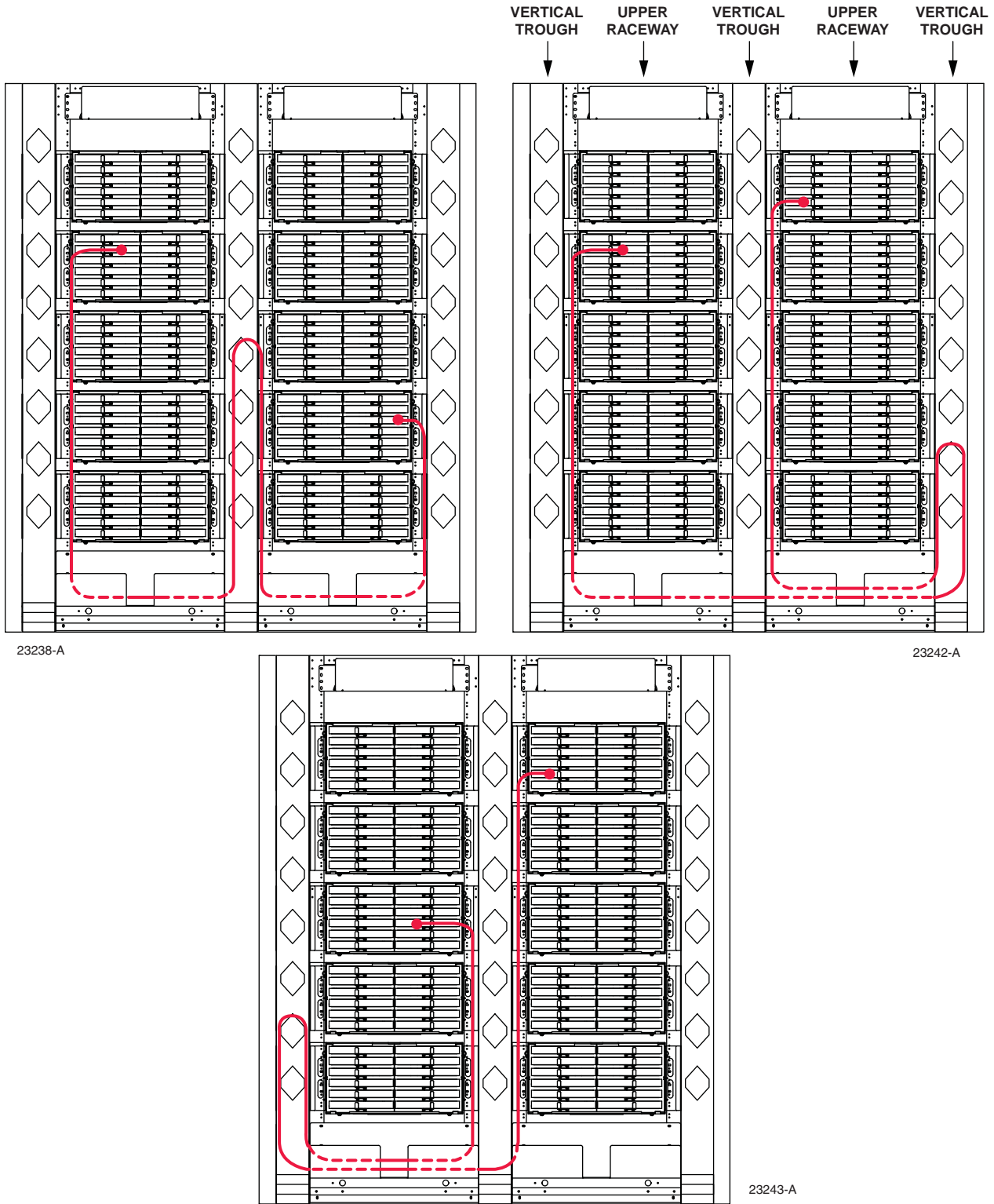

Figure 17. Alternate Paths for Patch Cords Between Adjacent Bays

4.6 Interconnect Procedures

In an interconnect configuration, route the patch cord from the Fiber Optical Terminal (FOT) equipment through an overhead or underfloor raceway as shown in [Figure 18](#). Take up slack using the vertical trough as shown in the figure.

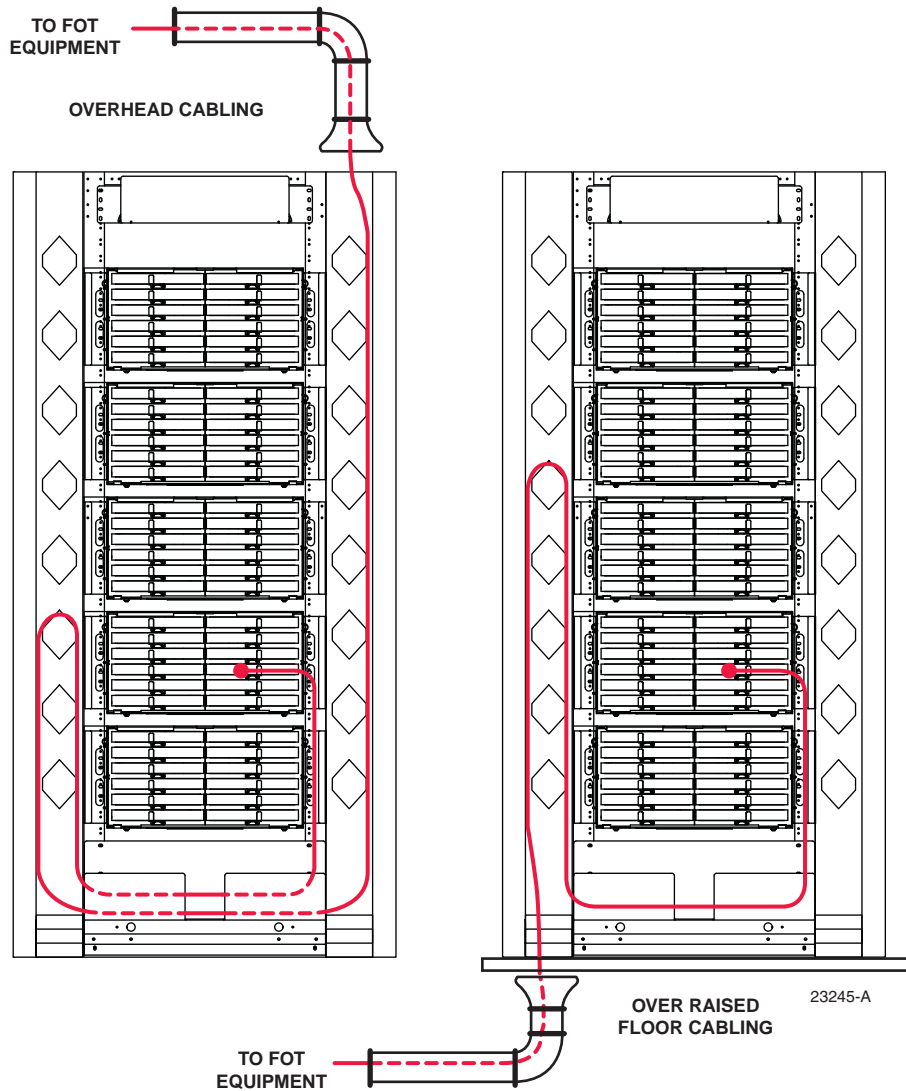

Figure 18. Routing Patch Cords Between Adjacent Bays

5 CUSTOMER INFORMATION AND ASSISTANCE

<http://www.commscope.com/SupportCenter>

COMMSCOPE®