

STARLINE Series

BLE100 1 GHz Line Extender

FEATURES

- Simplify plant upgrades with modular RF design and 1.2 GHz capable housing
- Improve amplifier reach with optional GaN technology and increased station tilt
- Maintain current amplifier spacing with high output GaAs technology
- Expand return path bandwidth with plug-in diplex filter support to 85 MHz
- Minimize RF drift over temperature with optional analog or QAM ADU

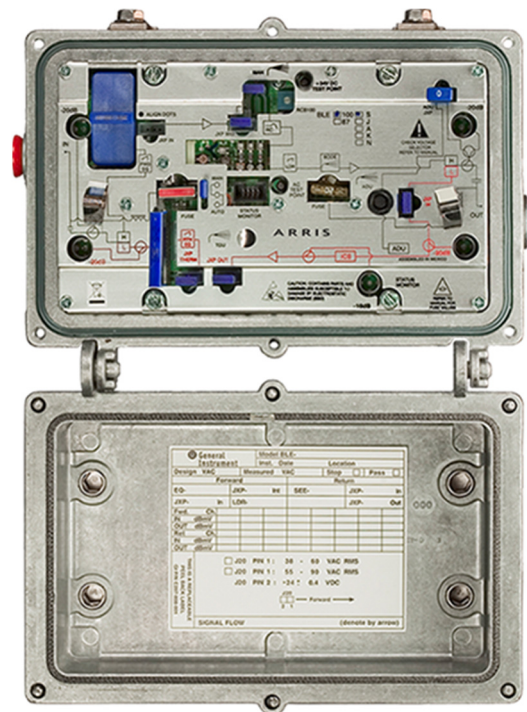

PRODUCT OVERVIEW

For cable operators looking to ensure maximum backward compatibility, scalability, and protect network investments, ARRIS offers solutions that deliver new services with minimal CAPEX, enhance network efficiency, and increase subscriber satisfaction.

The ARRIS BLE100 Line Extender enables cable operators to increase forward capacity while maintaining current amplifier spacing in their existing 750 and 870 MHz systems. The BLE100 is available as a complete unit for greenfield deployments or as a drop-in RF module for 1 GHz upgrades to legacy STARLINE™ BLE75 and BLE87 amplifiers.

Forward Path

The standard BLE100 configuration is equipped with second-generation Enhanced Gallium Arsenide (E-GaAs) technology, which provides superior distortion performance over standard silicon and competing GaAs technologies. If operators require longer reach, the BLE100 can be configured with optional Gallium Nitride (GaN) hybrid technology, which allows for a 3 dB increase in output level over the standard GaAs option.

To provide additional system flexibility, easy installation and maintenance, BLE amplifiers are compatible with standard accessories such as attenuators, equalizers, ADUs or QADUs, automotive fuses, and FTEC crowbar circuits. The amplifier maintains output level via an optional plug-in drive unit. In addition, operators can control level manually, thermally with the TDU (thermal drive unit) accessory, or electronically with the automatic drive unit (ADU). The ADU can support either analog or QAM pilot channels.

The BLE100 uses modular diplex filters, which operators can change to increase return bandwidth. The following filters are available for use with all US-style STARLINE RF distribution amplifiers (models BLE, MB/MBV3, BT):

- K-split (5 to 42 MHz/54 to 1003 MHz)
- A-split (5 to 65 MHz/85 to 1003 MHz)
- N-split (5 to 85 MHz/104 to 1003 MHz)

Return Path

The BLE100 comes standard with a high-gain return amplifier. Operators can select return path equalizers ranging from 0 to 12 dB. Thermal compensation is an optional feature, available as a JXP- TH°C plug-in, which stabilizes gain and match over temperature extremes.

Backward Compatibility

Operators can make the BLE100 electronics package backward compatible with 10-Amp BLE*/* housings by installing the BLE-15A Kit. These kits contain 50 mil gold-plated platform assemblies, which make it possible for the amplifier to carry 15 Amperes continuous through its input or output ports.

COMPATIBILITY

Platform	SLR	JLE	XLE	JLX	BLE-75SH	BLE-87
Upgrade to BLE100	No	No	No	Yes*	Yes*	Yes

* Requires BLE-15A Kit

RELATED PRODUCTS

ADU/QADU	MB100
MBV3	BT100
SFE/SRE EQ	Installation Services
Flex Max® RF Amplifiers	

Specifications – E-GaAs

Specifications	Units	Forward	Return
Frequency split ¹	MHz	K (54–1003) A (85–1003) N (104–1003) ¹⁹	K (5–42) A (5–65) N (5–85)
Flatness ^{2,19}	dB	± 0.7	± 0.5
Minimum Full Gain ³	dB	38	NA
Operation Gain ⁴	dB	34	24
Manual Bode Slope Control Range ⁵	dB	± 4	NA
Noise Figure ⁶	dB	9	5.5
Standard Slope Reference Frequency	MHz	1003/550/54	35 (flat)
Reference Output Level	dBmV	51/44/37	—
Operating Interstage Slope ⁷	dB	9 ± 1	NA
Standard Slope Performance			
Channels, Number of NTSC		79	6
Composite Triple Beat (CTB) ^{8,16}	-dBc	76	80
Cross Modulation (XM) ^{9,16}	-dBc	70	70
Composite Second Order (CSO) ^{8,10,16}	-dBc	70.5	81
Carrier to Intermodulation Noise (CIN) ^{8,16}	dB	65	—
Channels, Number of 256 QAM		154	—
Carrier to Intermodulation Noise (CIN) ²⁰	dB	65	—
Test Point ¹¹	dB	20 (± 1.0 dB)	20 (± 1.0 dB)
Return Loss ¹²	dB	16	15
Hum Modulation @ 12A	dBc	< 65 dB	< 60 dB
Hum Modulation @ 15A ¹²	dBc	< 60 dB	< 60 dB
DC Voltage	VDC		24
Current DC Max. ¹⁸	mA		920
Power Consumption Max.	W		35
AC Input Voltage Range (Pre August 2022 shipments)	VAC		38–90
AC Input Voltage Range (August 2022 shipments and later)	VAC		44–90
AC Current Draw Max	A		
@ 90 VAC			0.87
@ 60 VAC			0.99
@ 44 VAC			1.04
@ 38 VAC			1.04
AC Bypass Current (all ports) ¹⁴	A		15
Group Delay, K-split ¹⁵ 55.25 to 58.83 MHz	nSec	52	—
Group Delay, A-split ¹⁵ 86.25 to 90.68 MHz	nSec	28	—
Group Delay, N-split ^{15,19} 109.25 to 112.83 MHz 112.25 to 116.68 MHz	nSec	14 12	— —
Operating temperature range	°C °F		-40 to +60 -40 to +140
Housing dimensions, L x W x D	inches mm		10.6 x 8.0 x 4.7 270 x 204 x 120
Weight	lb kg		7.2 3.3

Specifications – E-GaN

Specifications	Units	Forward	Return
Frequency split ¹	MHz	K (54–1003) A (85–1003) N (104–1003) ¹⁹	K (5–42) A (5–65) N (5–85)
Flatness ^{2,19}	dB	± 0.7	± 0.5
Minimum Full Gain ³	dB	38	NA
Operation Gain ⁴	dB	34	24
Manual Bode Slope Control Range ⁵	dB	± 4	NA
Noise Figure ⁶	dB	10	5.5
Ultra Slope Reference Frequency ⁷	MHz	1003/550/54	35 (flat)
Reference Output Level	dBmV	57/48/39	—
Operating Interstage Slope	dB	13 ± 1	NA
Ultra Slope Performance			
Channels, Number of NTSC		79	6
Composite Triple Beat (CTB) ^{8,16}	-dBc	71	80
Cross Modulation (XM) ^{9,16}	-dBc	62	70
Composite Second Order (CSO) ^{8,10,16}	-dBc	68	81
Carrier to Intermodulation Noise (CIN) ²¹	dB	58	—
Channels, Number of 256 QAM		154	—
Carrier to Intermodulation Noise (CIN) ^{20,21}	dB	58	—
Standard Slope Reference Frequency ⁷	MHz	1003/550/54	35 (flat)
Reference Output Level	dBmV	51/44/37	—
Operating Interstage Slope ⁶	dB	9 ± 1	NA
Standard Slope Performance			
Channels, Number of NTSC		79	6
Composite Triple Beat (CTB) ^{8,16}	-dBc	76	80
Cross Modulation (XM) ^{9,16}	-dBc	70	70
Composite Second Order (CSO) ^{8,10,16}	-dBc	70.5	81
Carrier to Intermodulation Noise (CIN) ²¹	dB	66	—
Channels, Number of 256 QAM		154	—
Carrier to Intermodulation Noise (CIN) ^{20,21}	dB	66	—
Test Point ¹¹	dB	20 (± 1.0 dB)	20 (± 1.0 dB)
Return Loss ¹²	dB	16	15
Hum Modulation @ 12A	dBc	< 65	< 60
Hum Modulation @ 15A ¹⁸	dBc	< 60	< 60
DC Voltage	VDC		24
Current DC Max. ¹³	mA		920
Power Consumption Max	W		35
AC Input Voltage Range (Pre August 2022 shipments)	VAC		38–90
AC Input Voltage Range (August 2022 shipments and later)	VAC		44–90
AC Current Draw Max	A		
@ 90 VAC			0.87
@ 60 VAC			0.99
@ 44 VAC			1.04
@ 38 VAC			1.04

Specifications – E-GaN (continued)

Specifications	Units	Forward	Return
AC Bypass Current (all ports) ¹⁴	A		15
Group Delay, K-split ¹⁵ 55.25 to 58.83 MHz	nSec	52	–
Group Delay, A-split ¹⁵ 86.25 to 90.68 MHz	nSec	28	–
Group Delay, N-split ^{15,19} 109.25 to 112.83 MHz 112.25 to 116.68 MHz	nSec	14 12	– –
Operating temperature range	°C °F		-40 to +60 -40 to +140
Housing dimensions, L x W x D	inches mm		10.6 x 8.0 x 4.7 270 x 204 x 120
Housing Material Ingress Protection Rating			Aluminum IP68
Weight	lb kg		7.2 3.3

All specifications are stated as worst-case over temperature unless otherwise noted.

Notes:

- Operating passband of station. Diplex filters are plugged into the electronic chassis.
- Referenced to the average gain across the passband.
- Minimum full gain at 1003 MHz includes loss of equalizer but Bode slope reserves have not been set. Return gain includes loss of SRE*-4 return equalizer.
- Includes loss of slope reserves as well as equalizer.
- From midpoint (typical setting is -4 dB at 1003 MHz @ 25°C). This control should not be used for gain reduction.
- Specified at the housing cable entry facility over temperature and includes the loss of 1 dB for the pre-stage equalizer. The return noise figure includes the station loss preceding the RF hybrid.
- Amount of slope created and cable equivalence of fixed, plug-in interstage equalizer.
- Measured with CW carriers and spectrum analyzer over specified temperature range. References the worst-case channel.*
- Measured with wave analyzer and synchronous, 100% depth modulated channels. References the worst-case channels over specified temperature range. *
- Refers only to beat clusters that fall 0.75 MHz and 1.25 MHz above the subject picture carrier.
- Test points should be used with GFAL adapter.
- Match measurement at the station input and output, cable- entry facilities, at the specified passbands for operational gain.
- Current draw at 24 VDC.
- Stated in RMS continuous.
- Specified for standard NTSC video, where delay is the delta from picture carrier to 3.58 MHz color subcarrier. Reverse delay is in a 1.5 MHz bandwidth.
- Worst-case over temperature in a cascade.
- NTSC 79 Channel forward, 75 QAM carriers -6 dB relative to analog CW carriers. 6 Channel return.
- Hum mod is 55 dB from 5 to 10 MHz at 15A.
- For N-split (5–85/104–1003 MHz) roll-off from 105 MHz to 102 MHz < 1.0 dB. Group delay from 103.25 MHz to 105.25 MHz is < 22 ns.
- 154 QAM carriers 54–1002 MHz. Carriers are -6 dB relative to virtual analog levels.

* Specifications are compliant with the test methods as stated in NCTA Recommended Practices for Measurements on Cable Television

1 GHz BLE Ordering Guide

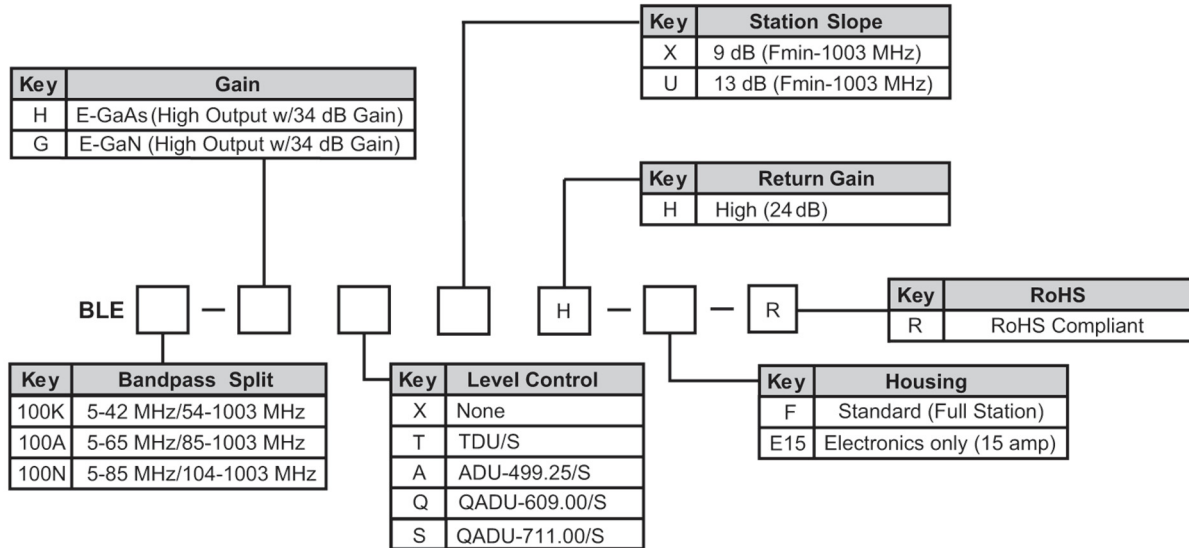

Notes:

1. Not all combinations in the ordering guide are available. This is a guide only.
2. FTECs are included in all models as standard.

Required Accessories

Part Number	Model Name	Description
535723-001-00	SFE-100-0	One of the following per BLE Forward 1003 MHz equalizer (0 dB) -or- Forward 1003 MHz equalizer (values 1 to 22 dB 1n 1 dB steps) -or- Cable simulator (values 1 to 10 dB in 1 dB steps)
531124-001 to -022	SFE-100-1 to -22	
531161-001 to -010	SCS-1 to SCS-10	
531163-XXX-00	SRE-*-*	Return equalizer, 5-42 MHz (K-split), 5-65 (A-split), 5-85 (N-split), values 0 to 12 dB in 2 dB steps
531186-XXX-00	JXP-*B	Plug-in pad/attenuator (values 0 to 26 dB in 1 dB steps)

Optional Accessories

Part Number	Model Name	Description
594742-002-00	QADU-609.00/S-R	609.00 MHz QAM Automatic Drive Unit
594742-001-00	QADU-711.00/S-R	711.00 MHz QAM Automatic Drive Unit
531236-003-00	ADU-499.25/S-R	499.25 MHz Automatic Drive Unit
531344-001-00	BLE-15A KIT	15 Amp kit to upgrade 10 Amp Line Extender Platform

Note: Specifications are subject to change without notice.

Customer Care

Contact Customer Care for product information and sales:

- United States: 866-36-ARRIS
- International: +1-678-473-5656

Copyright Statement: © 2022 CommScope, Inc. All rights reserved. ARRIS, the ARRIS logo, Flex Max, and STARLINE are trademarks of CommScope, Inc. and/or its affiliates. All other trademarks are the property of their respective owners. No part of this content may be reproduced in any form or by any means or used to make any derivative work (such as translation, transformation, or adaptation) without written permission from CommScope, Inc and/or its affiliates ("CommScope"). CommScope reserves the right to revise or change this content from time to time without obligation on the part of CommScope to provide notification of such revision or change.