

# TD-PCS-1-A5-D | E15Z50P63

---

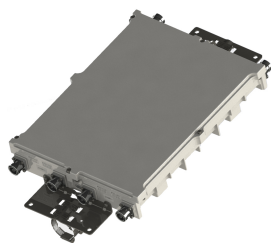

Twin Inband Diplexer PCS A5-D, DC sense

## **OBSOLETE**

### **Replaced By:**

CHB626-43-2X  
D15T01P38

Twin Hybrid Combiner

## Product Classification

**Product Type** Diplexer

## General Specifications

**Color** Gray

**Connector Interface** 7-16 DIN Female

## Dimensions

**Height** 465 mm | 18.307 in

**Width** 365 mm | 14.37 in

**Depth** 90 mm | 3.543 in

# TD-PCS-1-A5-D | E15Z50P63

## Outline Drawing

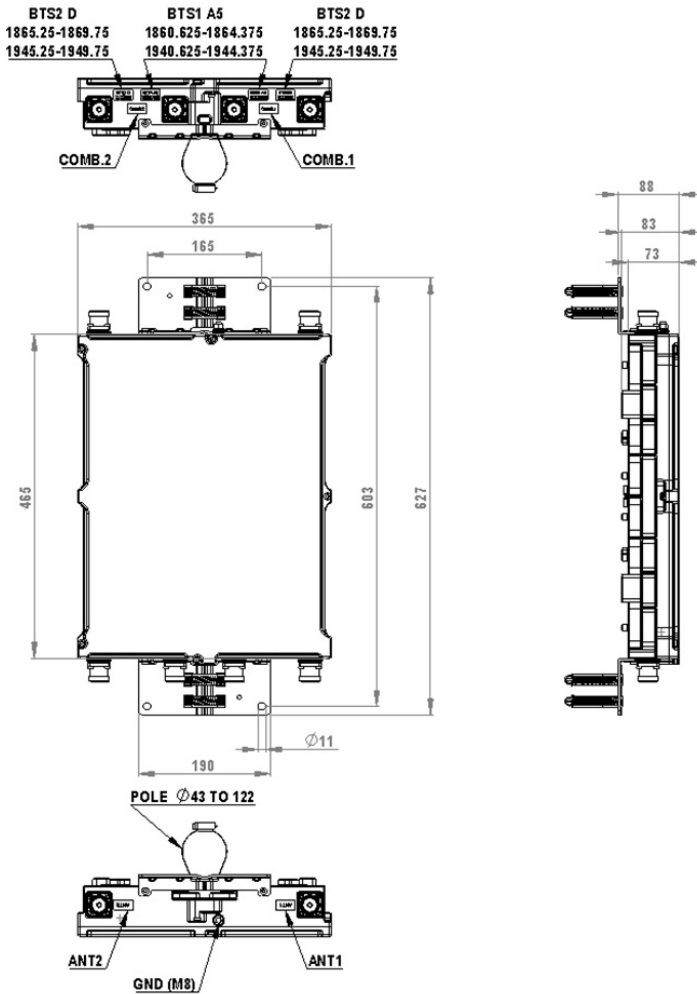

## Electrical Specifications

<b>5th Order IMD Test Method</b>	Two +43 dBm carriers
<b>5th Order IMD, maximum</b>	-153 dBc

## Electrical Specifications, Rx (Uplink)

<b>Frequency Band</b>	1860.625 – 1864.375 MHz
<b>Insertion Loss, typical</b>	0.8 dB
<b>Return Loss, typical</b>	18 dB
<b>Isolation, minimum</b>	28 dB
<b>Total Group Delay, maximum</b>	250 ns

# TD-PCS-1-A5-D | E15Z50P63

---

## Electrical Specifications 2, Rx (Uplink)

<b>Frequency Band</b>	1865.25 – 1869.75 MHz
<b>Isolation, minimum</b>	28 dB
<b>Isolation, typical</b>	28 dB
<b>Total Group Delay, maximum</b>	250 ns
<b>Insertion Loss, typical</b>	0.8 dB

## Electrical Specifications, Tx (Downlink)

<b>Frequency Band</b>	1940.625 – 1944.375 MHz
<b>Isolation, minimum</b>	28 dB
<b>Isolation, typical</b>	28 dB
<b>Input Power, PEP, maximum</b>	3000 W
<b>Input Power, RMS, maximum</b>	100 W
<b>Total Group Delay, maximum</b>	250 ns
<b>Insertion Loss, typical</b>	0.8 dB
<b>Return Loss, typical</b>	18 dB

## Electrical Specifications 2, Tx (Downlink)

<b>3rd Order IMD Test Method</b>	Two +43 dBm carriers
<b>Frequency Band</b>	1945.25 – 1949.75 MHz
<b>Input Power, PEP, maximum</b>	3000 W
<b>Insertion Loss, typical</b>	0.8 dB
<b>Isolation, minimum</b>	28 dB
<b>Isolation, typical</b>	28 dB
<b>Return Loss, minimum</b>	18 dB
<b>Return Loss, typical</b>	18 dB

## Block Diagram

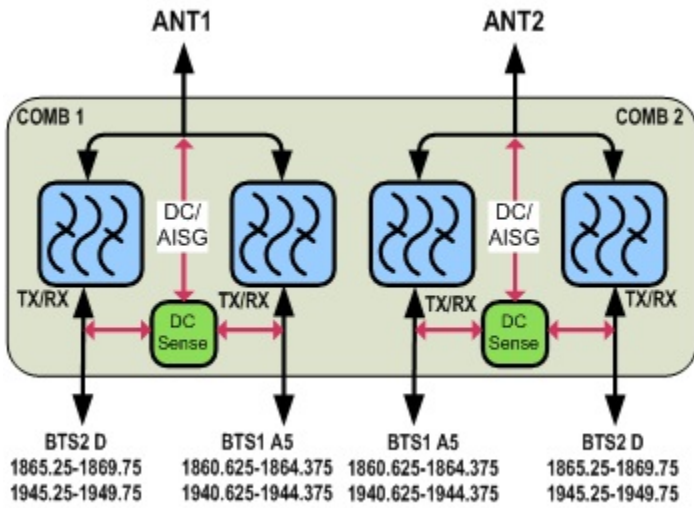

## Environmental Specifications

**Operating Temperature** -40 °C to +65 °C (-40 °F to +149 °F)  
**Ingress Protection Test Method** IEC 60529:2001, IP67

## Packaging and Weights

**Weight, net** 15.8 kg | 34.833 lb