

COMMSCOPE TELCO ALL-IN-ONE CABINET

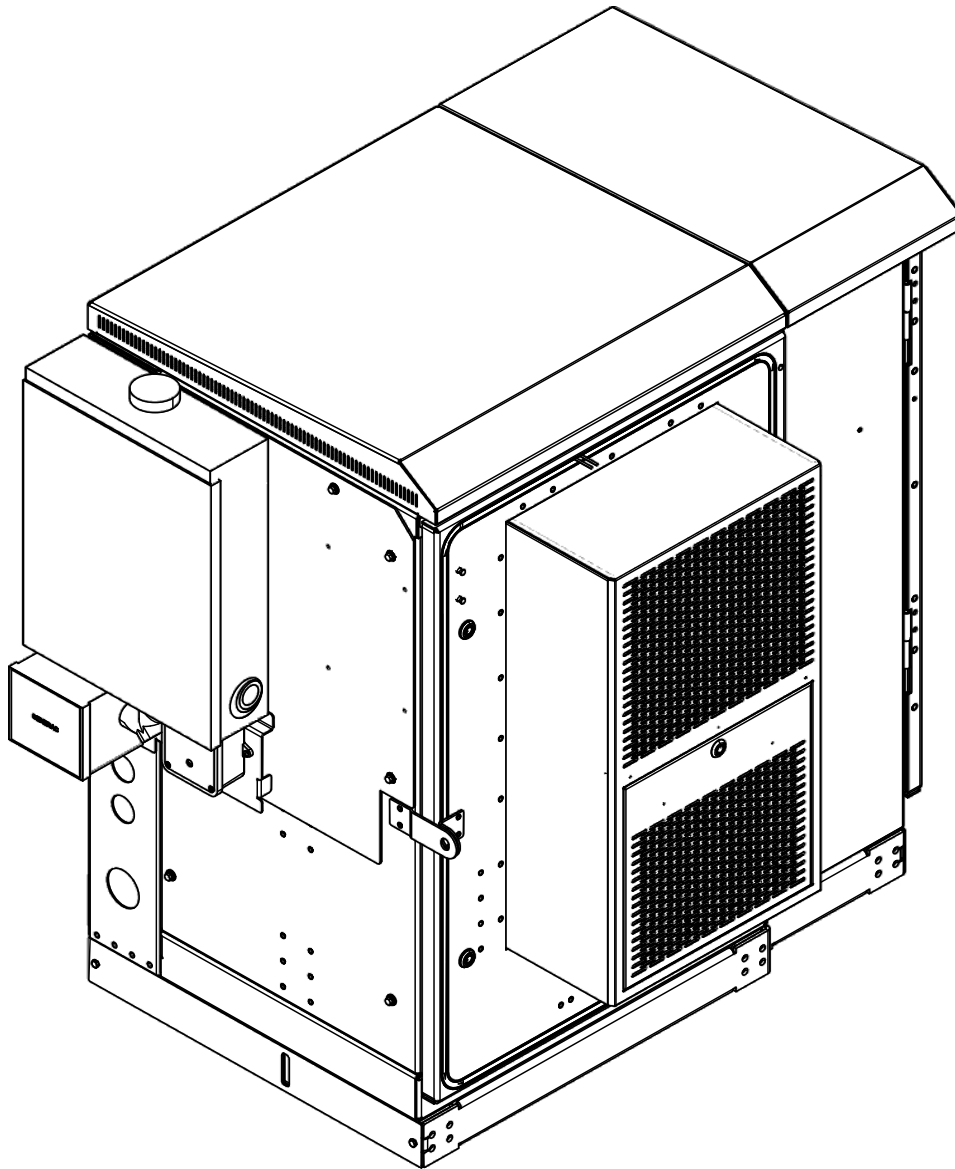

COMMSCOPE TELCO ALL-IN-ONE CABINET

Safety Agency Statements and Safety Precautions

Safety Agency Statements:

- Only qualified personnel are to install and maintain the cabinet.
- Install cabinet within a restricted access location where access is by use of a tool, lock and key or other means of security; and controlled by the authority responsible for the location.
- The cabinet is only suitable for mounting on a concrete or other noncombustible surface.
- Maximum ambient temperature (T_{ma}) of 46° C (115° F) permitted by manufacturer specification.
- All conduit hubs must be of Type 3R or equivalent to maintain the cabinet as Rainproof.
- It is essential to connect the cabinet to earth ground before connecting supply, high leakage current.
- All cabinet equipment cabling is to meet applicable NEC¹ and network communications standards.

Safety Precautions:

Note: *In areas that utilize joint buried plant, and per company practice, test and verify that voltage is not present on the cable shield. If voltage is present on the shield, stop work and notify supervision.*

- Follow all product warnings and instructions as specified in this document, cabinet and equipment labels inside the cabinet to reduce risk of fire, electric shock, and injury.
- Install all equipment and supplied hardware as specified in this document.
 - Install only approved devices in the cabinet and do not drill, saw, or cut inside the cabinet.
 - Never install cable, connectors, jacks in a wet location unless designed for wet locations.
 - Never install electrical equipment during a thunderstorm, there is risk of electric shock.
 - Never touch uninsulated live power wires or terminals, always disconnect from power first.
 - It is mandatory to use insulated tools using power and hand tools.
- Do not transport or lift cabinet with the batteries installed, or store batteries inside cabinet.
- All personnel must wear standard safety headgear, eye protection, and insulated gloves (if required).
- At all times, keep bystanders away from all work operations.

Warning:

Do not drill or punch any holes in the cabinet. Use only the provided knockouts in the cabinet for cable ingress and cable egress.

Drilling or punching holes in any other location will immediately void the warranty. No exemptions.

Contents

1	Overview and Specifications	4
1.1	Reference Documents and Manuals	4
1.2	Cabinet Weights (approximate)	4
1.3	CommScope Telco AIO Cabinet Rack Unit (RU) Configurations	4
1.4	Cabinet Views	5
1.5	Door View Examples with Air Conditioner Units	6
1.6	Door Clearances	7
1.7	Rear Panel Removal and Installation	8
1.8	Door Intrusion Alarm Switch	8
2	Concrete Pad Installation	8
2.1	Remove Packaging, Prepare Cabinet for Installation	8
2.2	Before Starting Installation	9
2.2.1	Installing a Support Base:	9
2.2.2	Mounting the Cabinet:	9
2.2.3	Splitter Installation:	9
2.2.4	Splitter Output Fiber Connections:	9
2.2.5	Unpacking and Inspection:	10
2.2.6	Outdoor Cabinet Installation Hardware:	10
2.2.7	OSP Cable and Cabinet Grounding Cables:	10
2.2.8	Tools and Materials Required for Installation:	10
2.2.9	Cabinet Mounting:	11
2.3	Alternate Mounting on a Steel Frame	11
2.4	Remove Pad Gasket from Cabinet and Prepare Pad	14
2.5	Place Cabinet onto Concrete Pad or Steel Structure	15
2.6	Fasten Cabinet to Concrete Pad or Vault	16
2.7	Route and Connect Cables	17
2.8	Mounting The Cabinet On A Vault, or Fiberglass Sleeve	18
2.9	Connect Cabinet to Main Earth Ground	20
2.10	Connect Cabinet to Outgoing Office Alarms	20
2.11	Connect Cabinet to Main Power Source, Turn-up	20
2.12	Power meter installation (optional)	21
3	Cabinet Battery Installation	22
3.1	Battery Safety Recommendations	22
3.2	Required Tools	22
3.3	Recommended Battery Dimensions and Battery Tray Configurations	23
3.4	Maximum Battery Dimensions	23
3.5	7RU Battery Tray Spacing Options – Battery Recommendations	23
3.6	Battery Voltage and Battery Supply Resistance	23
3.7	Battery System Resistance and Short Circuit Current Calculation	23
3.8	Battery Installation	24
3.8.1	Cabinet Preparation Prior to Installation, VRLA	24
3.8.2	VRLA Battery Installation	24
4	Appendix	26
4.1	Appendix Image 1	26
4.2	Appendix Image 2	27
4.3	Appendix Image 3	28
4.4	Appendix Image 4	29
4.5	Appendix Image 5	30
5	Disclaimer	31
6	Contact Information	31

1 Overview and Specifications

This guide provides instruction on how to install a CommScope Telco AIO cabinet onto a concrete pad, or below grade vault and battery installation.

Common Features

- All cabinets have same mounting footprint - Figure 12 & Figure 22
- Door with padlock, open/close turn-latches
- LED light and door intrusion switches - Figure 9
- With HVAC - Figure 6
- Ground bar (8-pos) - Figure 27
- Convenience outlet, GFCI (20 A)
- Large format allows 19 or 23-inch rack mounting
- Main earth ground lugs, bottom rear - Figure 27
- Rear access panel with open/close turn-latches and padlocks and environmental vents - Figure 2
- Side wall, rear, and floor knockouts for cable ingress/egress - Figure 2

1.1 Reference Documents and Manuals

Make sure to have these documents provided with the cabinet in hand at time of installation and refer to them as needed.

- **Installation Guide** – This document
- **Equipment Manuals** – Vendor manuals pertaining to equipment installed in the cabinet, such as a power system.

1.2 Cabinet Weights (approximate)

CommScope Telco AIO

- Empty Max Weight (no batteries, with or without equipment): 551 lbs. (250 Kgs)
- Weight with Pallet (no batteries): 700 lbs. (350 Kgs)
- Cabinet Weight with Batteries (after installation): See Table A, page 4

1.3 CommScope Telco AIO Cabinet Rack Unit (RU) Configurations

Table A shows RU space allocated to a cabinet based on number of battery strings with remaining RU space dedicated to cabinet equipment.

Note 1: All batteries must be of the same type and from same manufacturer. Do not mix battery types from different manufacturers.

Table A: Rack Unit Configurations per Number of Cabinet Battery Strings

Cabinet	No. of Battery Strings	Cabinet Weight After Battery Installation, with or without Equipment (see Note 1)	Max No. of Battery String RUs	Max No. of Equipment RUs (see Note 2)	Cooling Type
Telco AIO	0	551 lbs. (250 Kgs)	0RU	21RU	2KW DC HVAC
	1	1015 lbs. (507 Kgs)	7RU	14RU	

Note 2: Based on an average VRLA battery weight of 116 lbs. at 464 lbs. for one string of batteries plus weight of cabinet with or without equipment before battery installation.

Note 3: 2RU preinstalled PSU/rectifier options are available for purchase. ~2RU is generally reserved for such use. In addition, 1 RU is dedicated for the provided heating tray. Thus, 11RU of 19" or 23" rack equipment space remains unused for customer configuration.

1.4 Cabinet Views

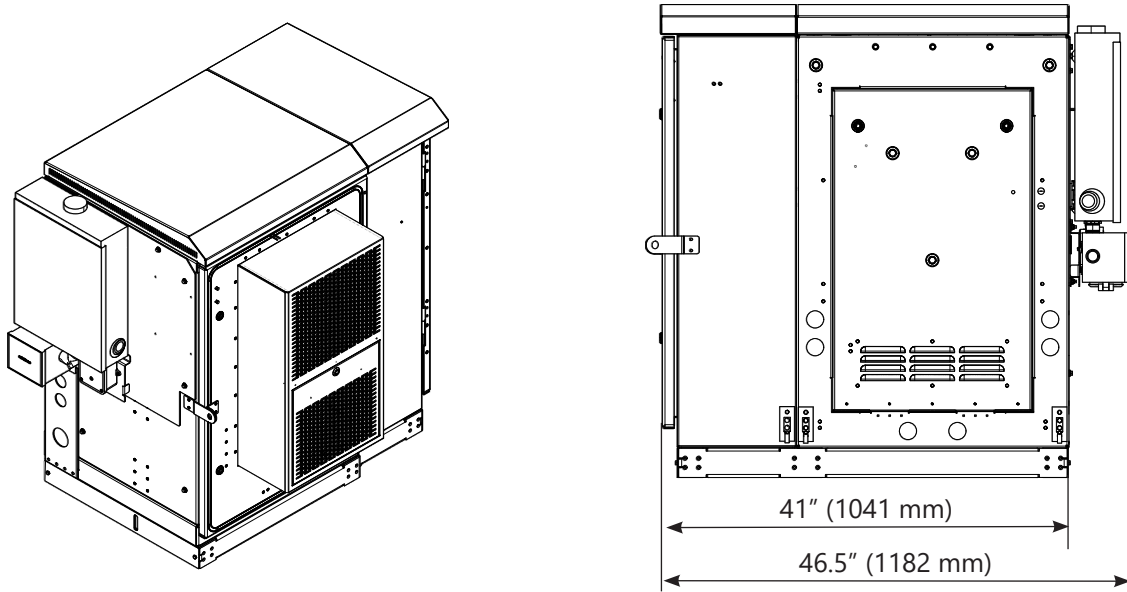

Figure 1. Isometric and Rear Views – CommScope Telco AIO Example

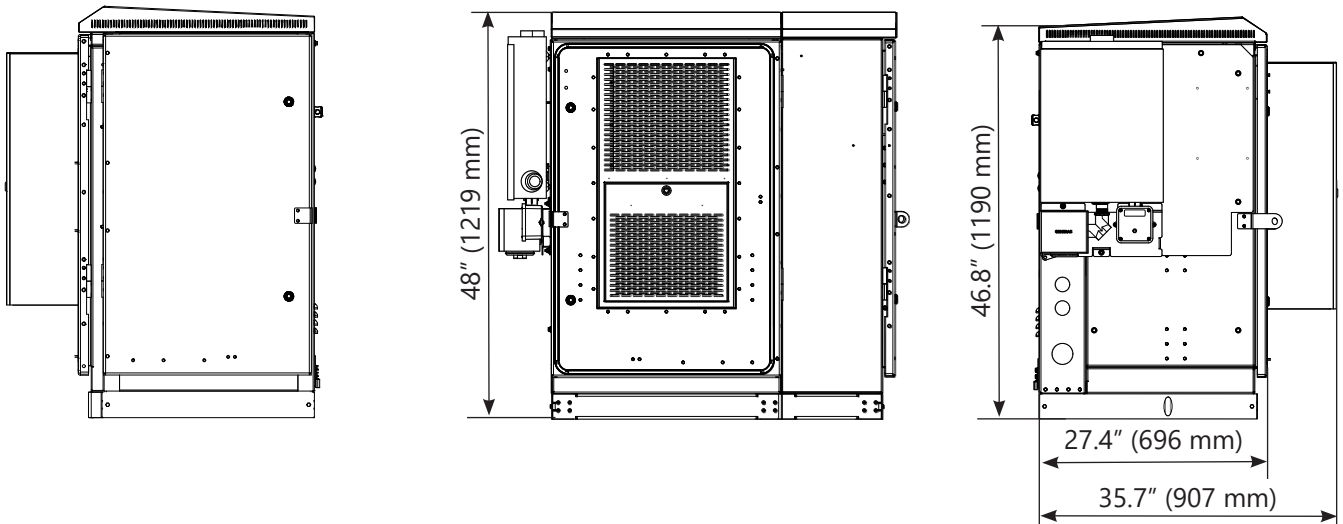

Figure 2. Left, Right, Front, and Left Views – CommScope Telco AIO Example

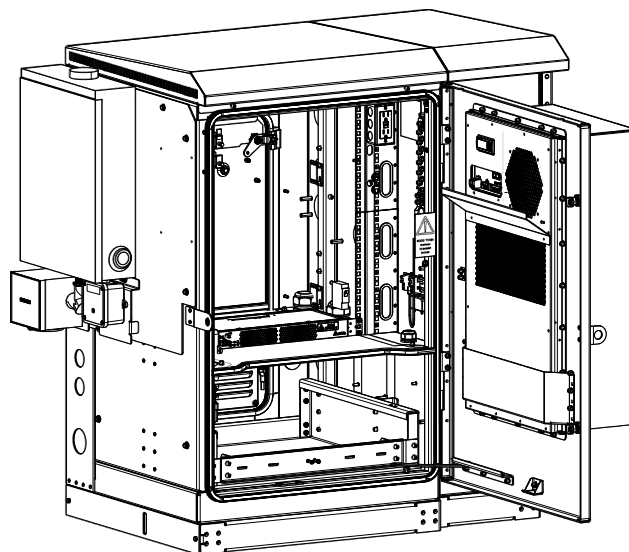

Figure 3. Compartment Views – CommScope Telco AIO Example

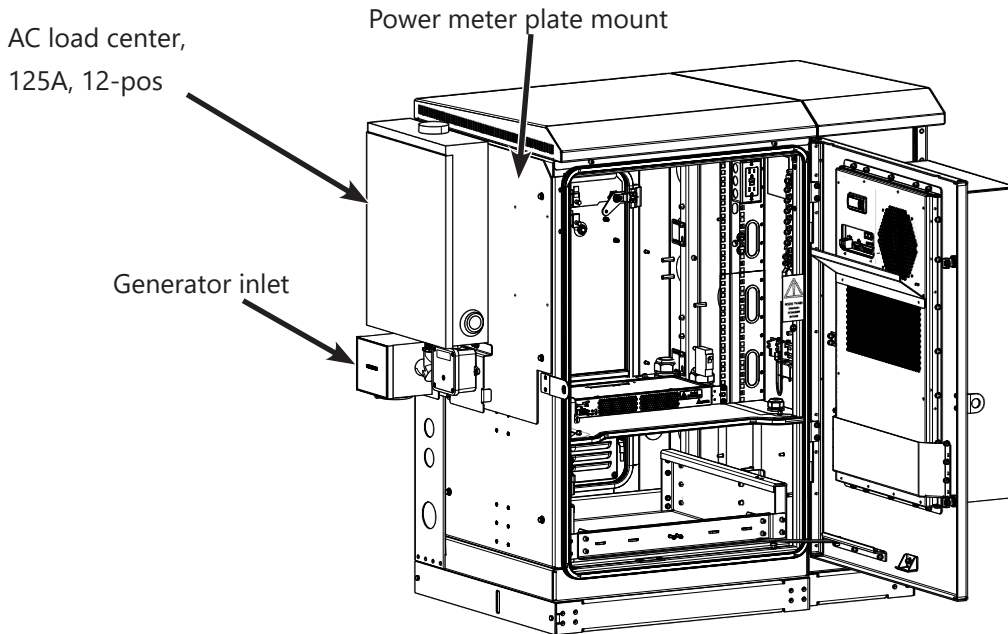

Figure 4. Left Side Views with 125Amp AC Load Center, CommScope Telco AIO Example

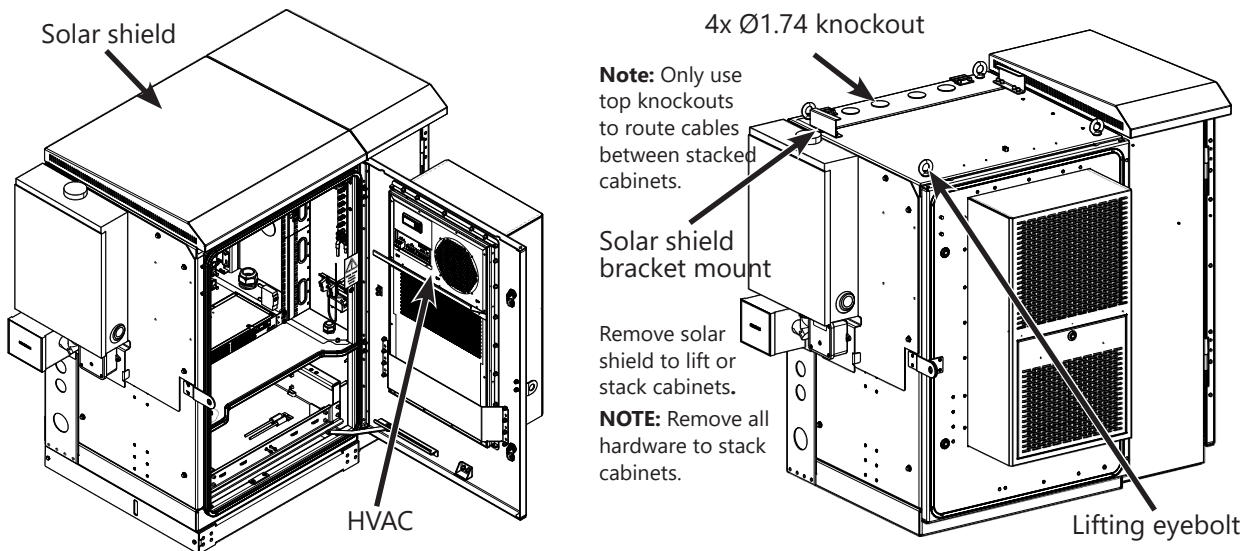

Figure 5. Equipment Cabinet with Solar Shield On or Off – CommScope Telco AIO Example

1.5 Door View Examples with Air Conditioner Units

Door with Air Conditioner: DC Power (D1-D7) (Figure 6)

A CommScope Telco AIO cabinet is equipped with a DC air conditioning unit to meet the operating requirements defined by the customer, as shown in Table A.

- All units have power input and alarm terminal blocks, I/O and RJ45 ports, and an interface display.
- The provided HVAC can remove 2KW of heat which is ~6,800 BTU/hr. Customer must account for both heat dissipation and solar loads. To facilitate air flow throughout the system, customer should strongly consider utilizing the CommScope provided "blanking plates" in their configuration. Even in 1 RU slots these plates help retain cool air in the back of the cabinet allowing the HVAC to pull warm air for cooling. Placing one "blanking plate" above the heater tray and one below the CommScope / customer provided PSU is recommended but obviously dependent on customer configurations.

DC Air Conditioner, D3

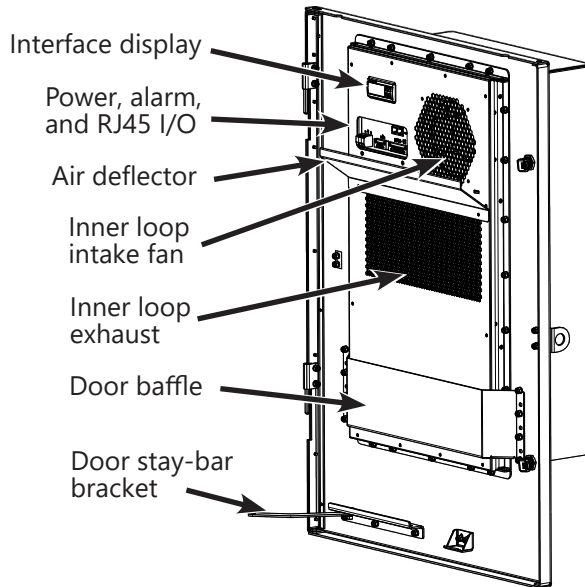

Figure 6. CommScope Telco AIO Door Examples with HVAC Units D3 per Table A

1.6 Door Clearances

Note: Figure 7 shows AC load center on cabinet right side to clarify door clearances. Optional AC load center can be mounted per customer request on either side.

Back-to-Front and Side-to-Side Dimensions, Door Open at 90° and 110°

A	Back-to-Front, Door 90° : 53.6" (1362 mm)
B	Side-to-Side, Door 90° : 37.1" (942 mm), HVAC
C	Back-to-Front, Door 110° : 51.9" (1318 mm)
D	Side-to-Side, Door 110° : 44" (1118 mm), HVAC

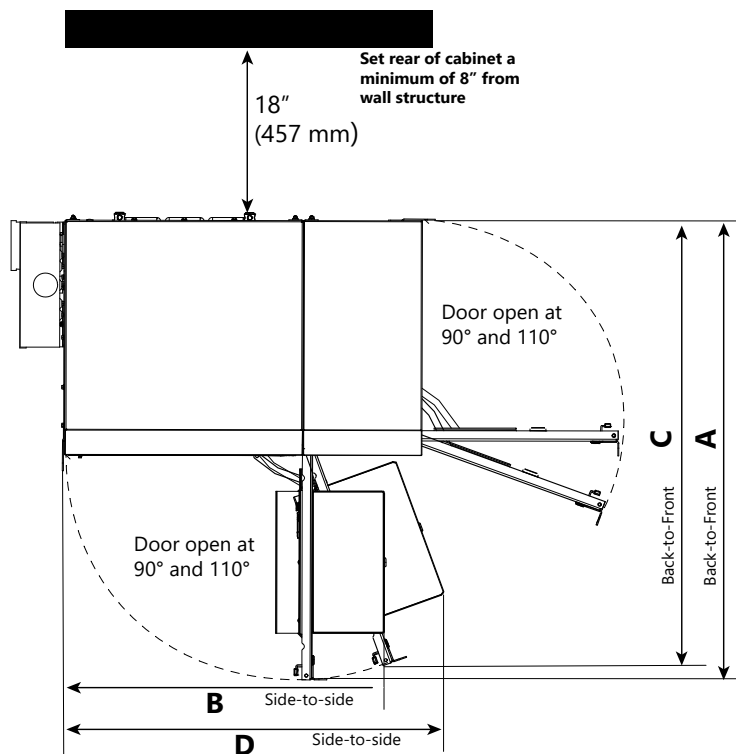

Figure 7. Top View, Door at 90° and 110° for CommScope Telco AIO

1.7 Rear Panel Removal and Installation

Prior to panel removal or installation, use door key (Figure 10) that ships with cabinet to open or close 1/4-turn latches when removing or installing a panel, Figure 8.

Note: Rear panel has ground cable attached on the inside of the panel.

Removal and Installation

• Removal

- Turn panel latches to open position and pull out top of panel first; then tilt panel out and pull up on panel to remove the panel from the opening.
- To remove the panel from the cabinet, disconnect ground cable from the green connector shown in Figure 8. Prior to replacing the panel, make sure to reconnect ground cable to green connector.

• Installation

- Tilt panel bottom in and insert bottom into cabinet, press into panel and close latches.

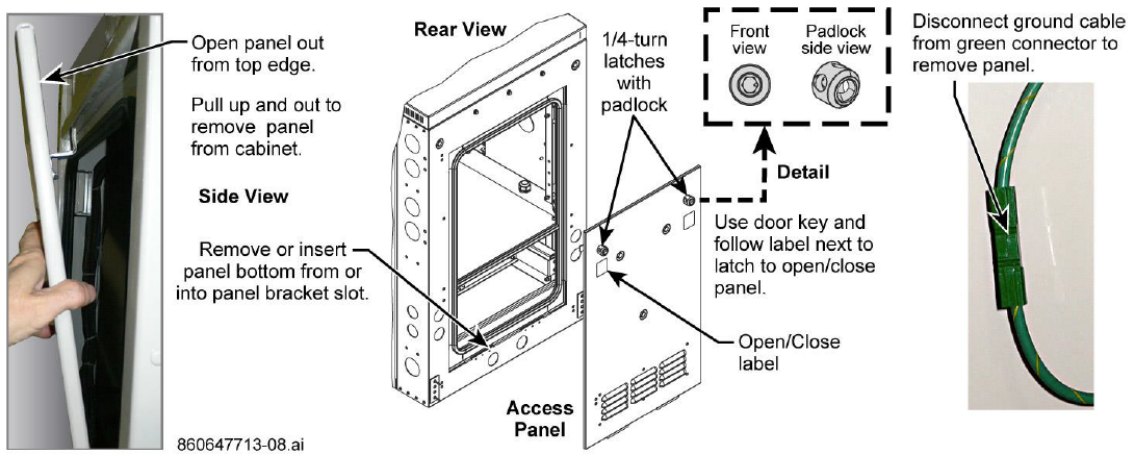

Figure 8. Rear Access Panel Removal and Installation, Ground Cable Disconnect

1.8 Door Intrusion Alarm Switch

The light and door intrusion switches are on the top left corner of the doorframe inside the cabinet. Connect the door alarm as required to an alarm center, Figure 9.

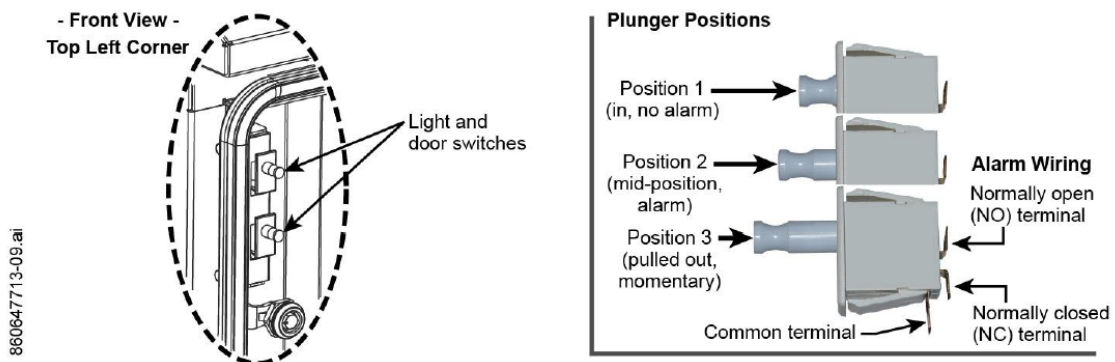

Figure 9. Light and Door Intrusion Switches

2 Concrete Pad Installation

2.1 Remove Packaging, Prepare Cabinet for Installation

Caution: Observe the following to prevent damage to the cabinet.

- Do not accept the cabinet from the shipper if the packaging appears damaged.
- Only remove the packaging and pallet at the installation site.
- Properly strap cabinet to a truck or trailer to prevent shifting, and always transport and store cabinet in an upright position.

- Use a forklift or the cabinet lifting brackets to raise and move the cabinet. Make sure the forklift tines are at least four feet long and check for correct installation of the cabinet lifting brackets beforehand.
- Do not remove the cabinet from pallet and open the door, cabinet tip-over may occur causing injury to field personnel.

To prepare cabinet for installation:

2.1.1 Remove all shipping material and the door key from the cabinet.

Note: Activate a low power heat source (a 60 W light) for humidity control if you do not place cabinet in service after installation.

2.1.2 Open door with door key, remove the installation kit, and close the door, Figure 3.

Note: Retain the pad gasket set between pallet and cabinet (required installation), Figure 18.

Table C: CommScope Telco AIO Cabinet Installation Kit (860463686)

Item	Qty	Description
1	1	AIO 7/16" Nut Driver Key (thin walled)
2	6	Cabinet Leveling Shims (2" squares)
3	6	1/2"-13x1.50 SS Hex Head Bolts
4	6	SS 1/2" Flat A-153 Type B Washers
5	1	10mm 3/8" Drive Socket
6	6	Red Rubber Gasket Washers
7	6	SS 1/2" Split Lock Washers



Figure 10. Cabinet Door Key

2.2 Before Starting Installation

This section provides general installation considerations, unpacking and inspection procedures, and lists the tools and materials required for cabinet installation.

Installation Overview:

Installation of CommScope Telco All-In-One Cabinet involves the following main tasks:

2.2.1 Installing a Support Base:

The cabinet must be mounted on a suitable support base. The following two mounting options are available:

- Fiberglass Mounting Sleeve (FMS) – The FMS is a rectangular sleeve that mounts in the ground. The FMS provides a stable mounting platform plus storage space under the cabinet for OSP cable slack. The FMS may also be used as a splicing vault for OSP cables.
- Poured Concrete Pad – Concrete slab with Pad Mounting Frame (PMF). The PMF is a stainless-steel frame that is embedded in the concrete during installation of the slab. The cabinet attaches to the PMF which holds it securely to the slab.

2.2.2 Mounting the Cabinet:

After the support base is installed, the cabinet must be secured to the support base. The OSP feeder cable must be uncoiled and routed to a separate splice enclosure (not provided) before the cabinet is secured to the support base.

2.2.3 Splitter Installation:

Splitter modules are ordered separately and must be installed in the splitter compartment. The input connectors must be mated with the terminated feeder cable fibers.

2.2.4 Splitter Output Fiber Connections:

Service is enabled by connecting the splitter output pigtails or red pass-through jumper fiber connectors to the subscriber distribution ports. Unused output or jumper fibers can be temporarily "parked" in the fiber distribution door storage panel until they are needed for service. A total of six, 16 position, parking lot adapters are preinstalled for this purpose.

2.2.5 Unpacking and Inspection:

This section provides instructions for opening the shipping boxes, verifying that all parts have been received and verifying that no shipping damage has occurred.

Use the following procedures to unpack and inspect the cabinet and all accessories:

2.2.5.1 Open the shipping carton(s) and carefully unpack the cabinet and any accessories from the protective packing material.

2.2.5.2 Open the cabinet doors (requires 216B key tool) and check for missing ship-along parts (see installation drawing included with cabinet) or broken parts. If there are damages, contact CommScope for an RMA (Return Material Authorization) and to reorder if replacement is required.

2.2.6 Outdoor Cabinet Installation Hardware:

The outdoor cabinet is shipped with various parts (see Table C) for securing the cabinet to the FMS or PMF. Verify that the parts specified are received.

2.2.7 OSP Cable and Cabinet Grounding Cables:

The cabinet is equipped with a common grounding block that is used to tie together all the components of the cabinet that must be grounded. OSP cables with metallic shield and/or strength members must be bonded and grounded according to NEC guidelines. Information on grounding is provided in the sections that cover cabinet mounting.

2.2.8 Tools and Materials Required for Installation:

All Cabinet Installations

- Hammer
- Duct Seal (For Conduits/ Glands)
- Wire cutter
- Utility knife
- Screwdriver (flat blade)
- Tape measure
- Pen or marker
- 216B key tool (required to open cabinet door)
- Padlock (optional)
- Grounding system, copper wire, and grounding clamp (per local requirements)
- Splicing equipment for splicing OSP feeder and distribution cables
- One large tweezers or two small flat-bladed screwdrivers
- Lifting equipment for hoisting the cabinet into position for mounting

Fiberglass Mounting Sleeve Installation

- Fiberglass Mounting Sleeve kit (FMS-FD3J-KIT-B)
- 9/16-inch wrench
- Security key (accessory - required to remove lifting eyes)
- Excavation and earth moving equipment
- Stone aggregate
- Tamping equipment
- Level
- Hole saw and drill (use to cut holes for cable conduit if pre-drilled holes are not usable)
- Landscaping equipment and site restoration supplies

Concrete Pad Installation

- Pad Mount Frame kit
- 9/16-inch wrench
- Security key (accessory - required to remove lifting eyes)
- Excavation and earth moving equipment
- Concrete finishing equipment
- Approximately 11.5 cu. ft. concrete
- Sand or gravel
- Tamping equipment
- 2 x 6-inch framing lumber
- 1 x 4-inch wooden stakes (4)
- Nails and construction screws
- Utility wire (to secure PMF during installation)
- Saw
- Drill with screwdriver bits
- Square
- Level
- Landscaping equipment and site restoration supplies

2.2.9 Cabinet Mounting:

The next two sections provide installation instructions for the mounting the cabinet on either an below grade vault or a concrete pad. Use whichever procedure is appropriate for the installation.

2.3 Alternate Mounting on a Steel Frame

The Pad Mount Frame, shown in Figure 11, is a stainless-steel frame that provides a mounting base for the cabinet when embedded in a concrete foundation.



Caution: Mounting the cabinet directly on a concrete pad may cause chemical corrosive action to the cabinet. Use only the Pad Mount Frame (PMF) as a mounting base for the cabinet. Do not use caulking compounds as a sealer between the cabinet and the PMF.

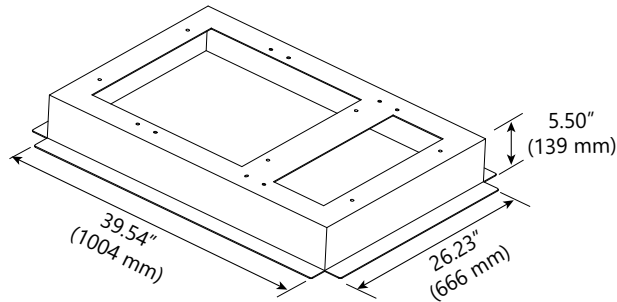

Figure 11. Pad Mount Frame Dimensions

Installation Recommendations:

- The site chosen for the installation must conform to all local codes and any permits required must be obtained prior to the start of installation.
- The location must be accessible and provide adequate parking for worker and vehicle safety.
- Situate the concrete pad close to the trench that was used for routing the OSP fiber cables for the network distribution system.
- The installed cabinet must not create a visual or physical obstruction to vehicular or pedestrian traffic.
- Ensure that there is sufficient space on all sides to facilitate cabinet installation.
- Depending on the landscaping requirements, the top surface of the concrete pad may be located from 0 to 3 inches (7.6 cm) above the surrounding grade.

Base Construction and Conduit Installation:

- Prepare a base for the concrete pad that meets all local code requirements.
- The base must have a footing of 4 to 6 inches (10.2 to 15.2 cm) of sand or gravel (per local practice) on firmly compacted soil.
- Refer to the construction diagram in Figure 12 for details.
- Install the cable conduit from below and position it so that the top of each upward bend will be located within the PMF opening at the indicated point.
- When installed, the top of the conduit should be located 1 to 2 inches (2.54 to 5.08 cm) **below** the top of the finished concrete pad.
- Install the conduit **before** pouring the pad.

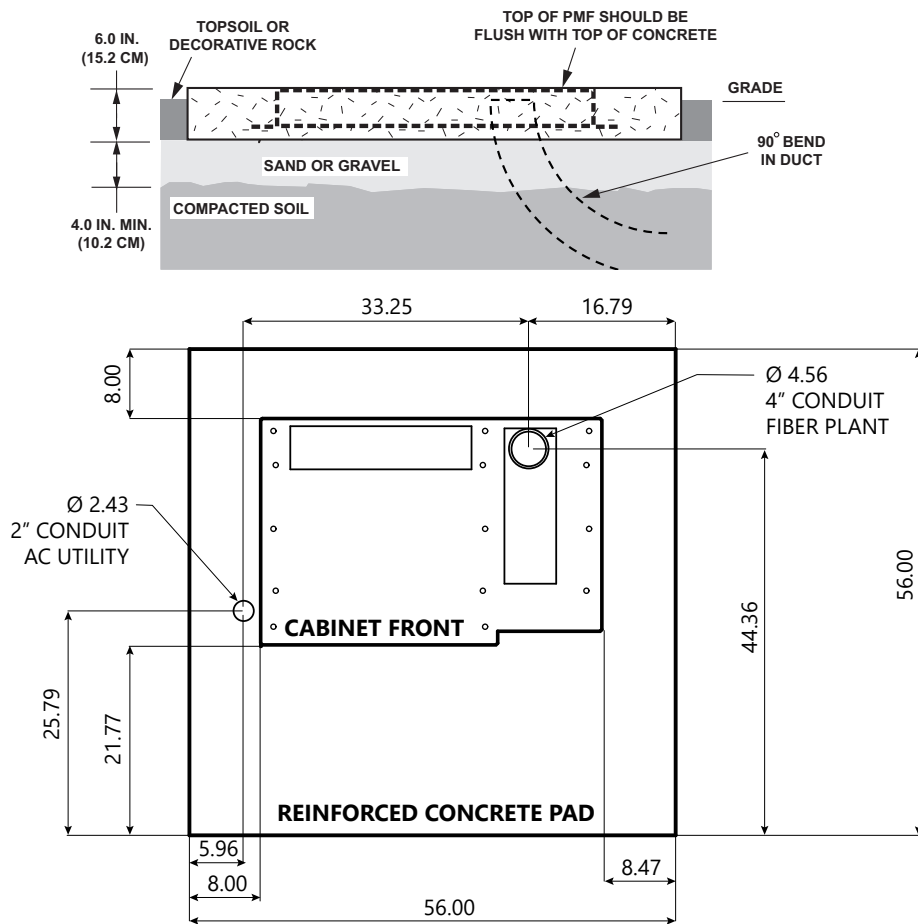

Figure 12. Example of Cabinet Installation with 3-Inch Plinth on a Concrete Pad

- A template is provided with the cabinet isolation gasket.
- The template may be used to determine the cable conduit locations.
- Place the template over the top of the PMF and align the top right corner of the template with the top right corner of the PMF as shown in Figure 13.
- The holes punched in the template show the locations for the conduit within the PMF.

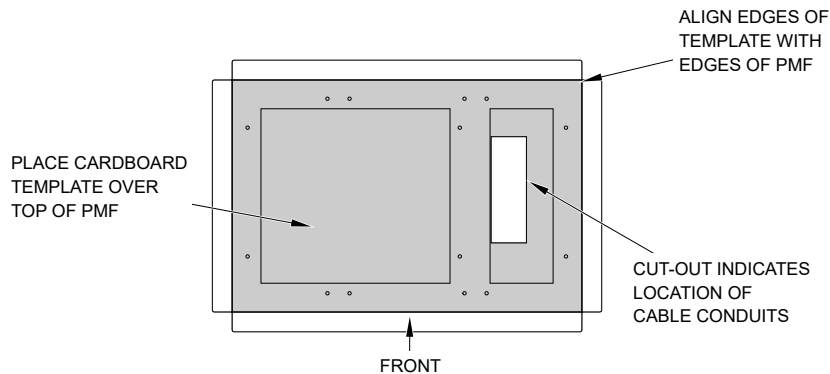

Figure 13. Using the Template To Determine Duct Location Within the PMF

Concrete Pad Construction:

Use the following procedure to construct the concrete pad:

- Build a wood form for the concrete pad using 2 x 6 framing lumber as shown in Figure 14.
- Locate the PMF as shown in the construction diagram (see Figure 12). When installed, the top surface of the PMF must be flush and level with the top of the concrete pad.

Note: Use temporary top framing to keep the top surface of the PMF flush and level with the top of the concrete pad (see Figure 14).

- Place reinforcing material inside the form but outside of the PMF.
- Verify that the PMF and form are level. Depending on the landscaping requirements, the top surface of the concrete pad may be 0 to 3 inches (0 to 7.6 cm) above the final grade. The weld nuts are covered with plugs which must be left in place until the enclosure is mounted.

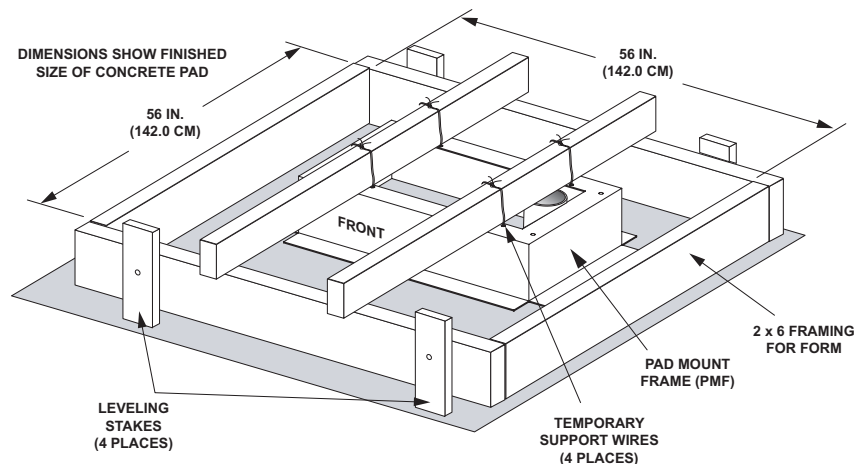

Figure 14. Concrete Pad Framing

- Pour the concrete to form the pad but do not pour concrete into the center area of the PMF.

Note: Allow some concrete to flow under the flanges on the bottom of the PMF so the PMF will be locked in place when the concrete hardens. However, do not allow concrete to fill the center of the PMF. If necessary, partially fill the center of the PMF with sand or gravel to prevent an inflow of concrete.

- Remove the top framing and the temporary support wires when the concrete is ready to be finished.
- Allow concrete to cure before proceeding with the installation.

Grounding System Installation:

Install a grounding system (not provided) that meets all local electrical codes. Check local codes for grounding system installation, use of clamps, wire size, and any other grounding requirements. Typically, #6 AWG copper wire is used for the ground wire. If the grounding system includes a ground rod, install the rod (see Figure 12) within the PMF opening at the indicated point. When installed, the top of the rod should be located 1 to 2 inches (2.54 to 5.08 cm) below the top of the finished concrete pad. Leave sufficient slack in the grounding wire to allow it to be routed into the cabinet after the cabinet is mounted on the pad.

Mounting the Cabinet on the Concrete Pad:

Use the 216B key tool to un-latch and latch the cabinet doors as needed during the mounting process. Refer to Figure 15 as necessary when mounting the cabinet.



Warning: Mounting the cabinet directly on a concrete pad may cause chemical corrosive action to the cabinet. Use only the Pad Mount Frame (PMF) as a mounting base for the cabinet. Do not use caulking compounds as a sealer between the cabinet and the PMF.

Use the following procedure to mount the cabinet on the concrete pad:

1. Use a 3/16-inch security hex-head wrench to remove the screws that secure the access covers to the left and right sides of the cabinet ground spacer/riser.
2. Remove the plastic plugs that are installed in the threaded corner holes of the PMF and clean off any concrete that may have adhered to the top of the PMF.

Note: Make sure all remnants of concrete are removed from the PMF prior to mounting the cabinet. It is not necessary to use shims to level or align the cabinet as long as the top surface of the PMF is clean and free of any installation debris.

3. Place the isolation gasket (provided with cabinet) on the PMF and align the holes in the gasket with the holes in the PMF. Make sure the wide side of the gasket is on the side of the PMF that corresponds to the front side of the cabinet.
4. If a ground spacer/riser (accessory) will be installed, place the spacer/riser in position for mounting on the PMF. The isolation gasket installed in step 3 should remain in place between the PMF and spacer/riser. If a spacer/riser will not be installed, proceed to step 7.
5. Align the mounting holes in the spacer/riser with the mounting holes in the PMF.
6. Secure the spacer/riser to the PMF using the four cap screws, four lock washers, and four flat washers provided. Tighten all cap screws securely.
7. Using appropriate lifting equipment, hoist the cabinet several feet into the air to provide access to the feeder and distribution cables.



Danger: Do not stand directly under the cabinet as it is being hoisted into position for cable installation. A failure of the lifting equipment could result in serious personal injury.

Note: Label or tag the stub end of each cable so it can be identified after it is routed to the splice enclosure.

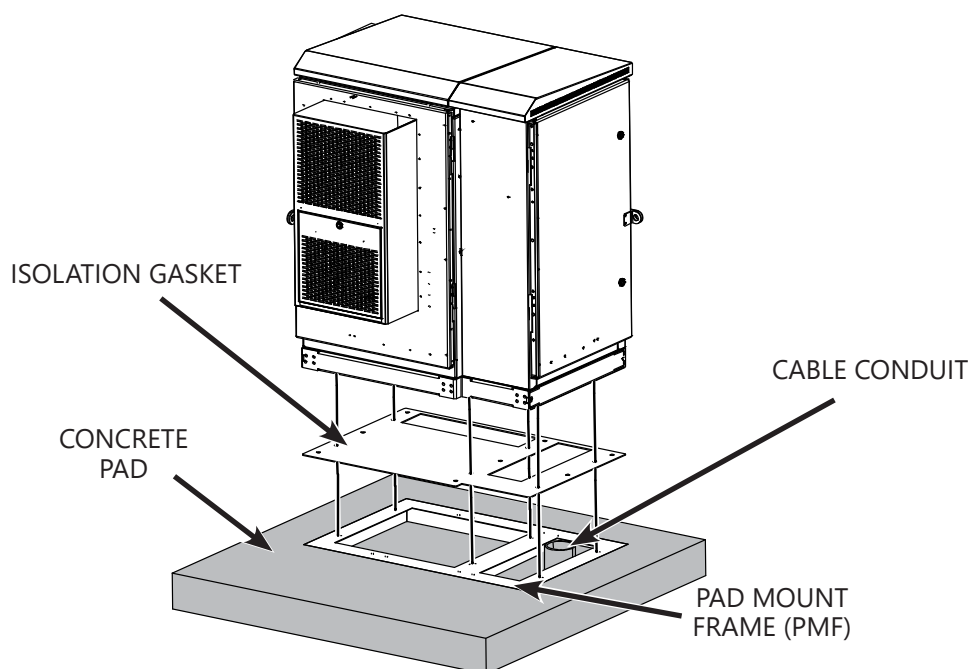

Figure 15. Mounting the All In One Cabinet on the Concrete Pad

8. Feed the stubbed feeder and distribution cables into the appropriate conduit sections and route to the splice enclosure (not provided).

Note: A separate splice enclosure (not provided) is required for splicing the cabinet OSP feeder and distribution cables to the network cables.

9. Lower the cabinet onto the vault or PMF and align the mounting holes in the cabinet base with the threaded holes in the PMF. If a spacer/riser was not installed, leave the isolation gasket (installed in step 3) in place on the PMF.
10. Secure the cabinet to the spacer/riser or PMF using the eight cap screws, eight lock washers, and eight flat washers provided with the cabinet. Tighten all eight cap screws securely.
11. For safety, the lifting eyes must be removed from the cabinet and either a) placed in the cabinet, or b) reinstalled upside down. Use the security key tool (accessory) to remove the lifting eye screws. For option a), store the lifting eyes inside the cabinet and then re-install the lifting eye screws in the cabinet. For option b), turn the lifting eyes upside down and then secure them to the cabinet with the original screws.

2.4 Remove Pad Gasket from Cabinet and Prepare Pad

Caution:

- Do not install batteries in cabinet prior to cabinet installation on pad (structure).
- Install cabinet on a pad six inches above the grade to prevent water intrusion and install all cable connections, including ground cable, above the pad (structure).

To remove pad gasket:

1. Open the door and rear panel to locate and remove pallet bolts (six places) from front and rear corners on cabinet floor or base of plinth; Figure 16.
 - Pad gasket is between the cabinet floor or base of plinth on pallet. Use pad gasket as a template to drill anchor holes into the concrete; Figure 16 & Figure 18.
2. Remove solar shield to reveal the four eye bolts on the cabinet top, Figure 17.
 - Unscrew the M6-12 cap screws, lift solar shield and slide it back to release from cabinet.
3. Close door and lift cabinet with appropriate lifting device to remove gasket, reset cabinet onto pallet.

Note: If routing cable through pad (structure), remove floor knockouts (punch outside to inside) before installing cabinet; Figure 13.

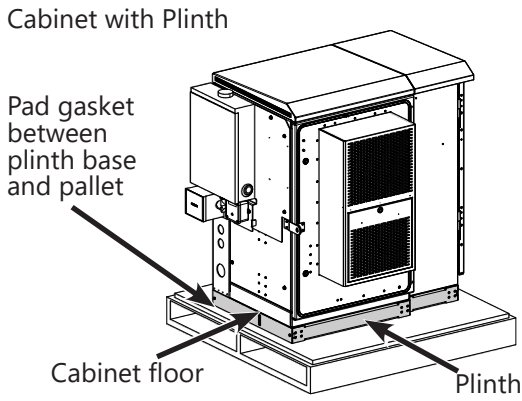

Figure 16. Pad Gasket Removal from Pallet

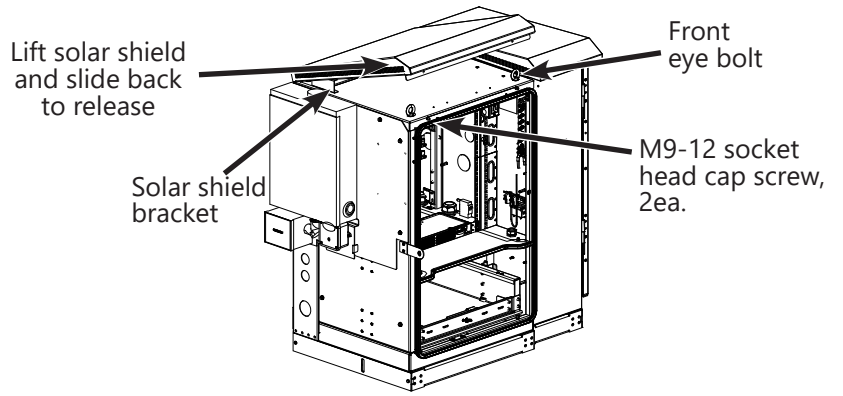
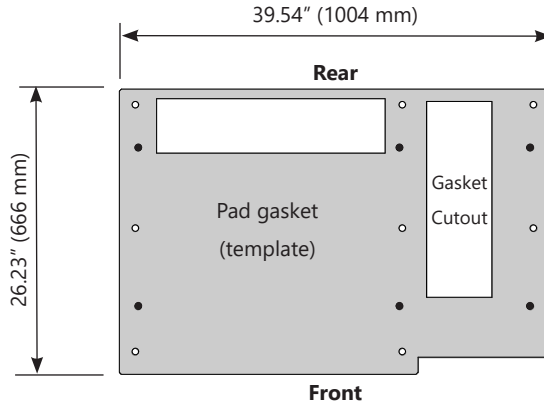

Figure 17. Solar Shield Removal



• = Pallet bolt and anchor hole locations on cabinet floor

Figure 18. Gasket (Template) Required Between Cabinet and Pad or Vault

To prepare the pad:

1. Place gasket (template) onto pad in location where cabinet will be installed and mark front and rear anchor locations per Figure 18.
2. Do the following:
 - a. Drill six holes using the correct diameter drill bit to fit anchors in place, and to correct depth.
 - b. Remove drilling debris with a blowout bulb or compressed air, then clean pad of dirt and debris for proper cabinet leveling.

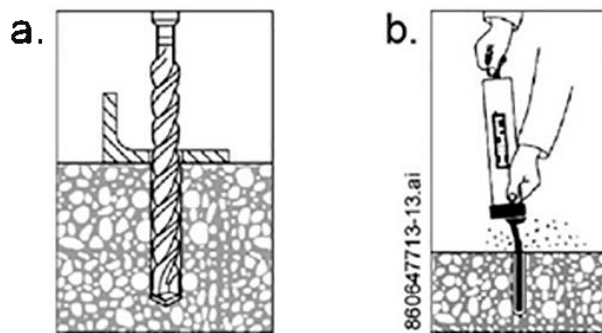

Figure 19. Drill Anchor Holes and Remove Debris

2.5 Place Cabinet onto Concrete Pad or Steel Structure

⚠ Caution:

- Verify all anchor holes are in correct position before putting cabinet onto concrete pad; or if on a steel structure, verify proper position and alignment per structure footprint.
- Use an appropriate lifting device to place cabinet onto pad or structure.
- Do not install batteries in cabinet or lift cabinet with batteries prior to cabinet pad installation.

To lift and position cabinet onto a concrete pad or steel structure:

1. Remove cabinet rear panel and use all four eyebolts to lift the cabinet, Figure 20

- Attach four slings of sufficient length for safe operation to boom line with a B connecting link or clevis and fasten other ends of slings to each eyebolt with a B connecting link or clevis, Figure 20.

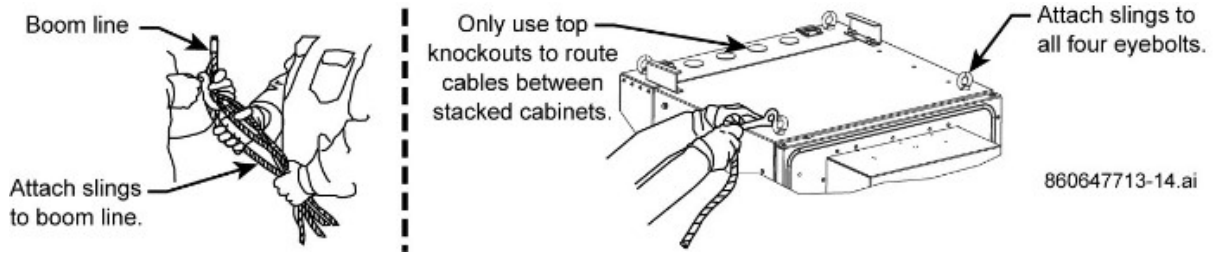

Figure 20. Attach Slings to the Boom Line and Cabinet Eyebolts

- With cabinet suspended, open the door and align floor holes to pad anchors, setting cabinet onto gasket; Figure 12 without plinth, Figure 13 with plinth.

Note: If routing cable through pad (structure), remove floor knockouts before placing cabinet onto gasket; Figure 11, Figure 12, Figure 18 and Figure 27.

2.6 Fasten Cabinet to Concrete Pad or Vault

- Fasten cabinet to a concrete pad or vault from cabinet pad mount holes per Figure 18 and Figure 21. CommScope requires use of eight mounting holes.
 - For pad installations, customer provides anchors or inserts to fit the 1/2"-13 x 1.5" bolts provided with the installation kit, Table C.
 - For structures, customer provides adequate hardware to fasten cabinet to the structure.
 - For cabinet with plinth, see Figure 22 to mount cabinet to pad.

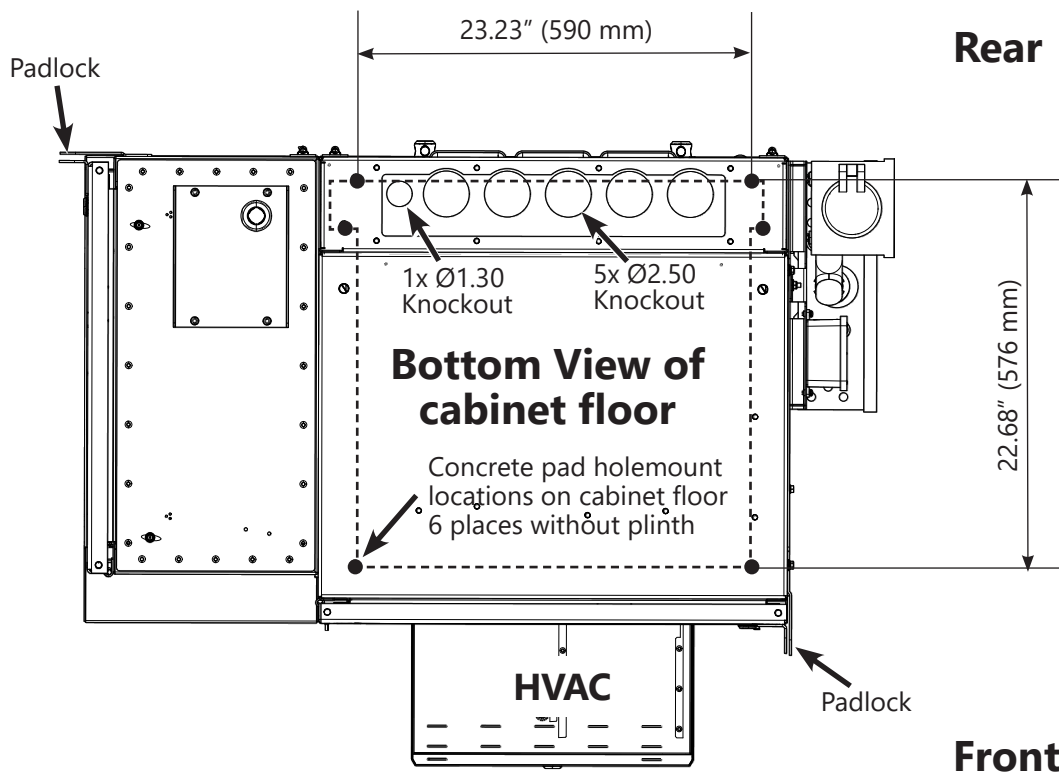

Figure 21. Mounting Footprint for CommScope Telco All-In-One Cabinet

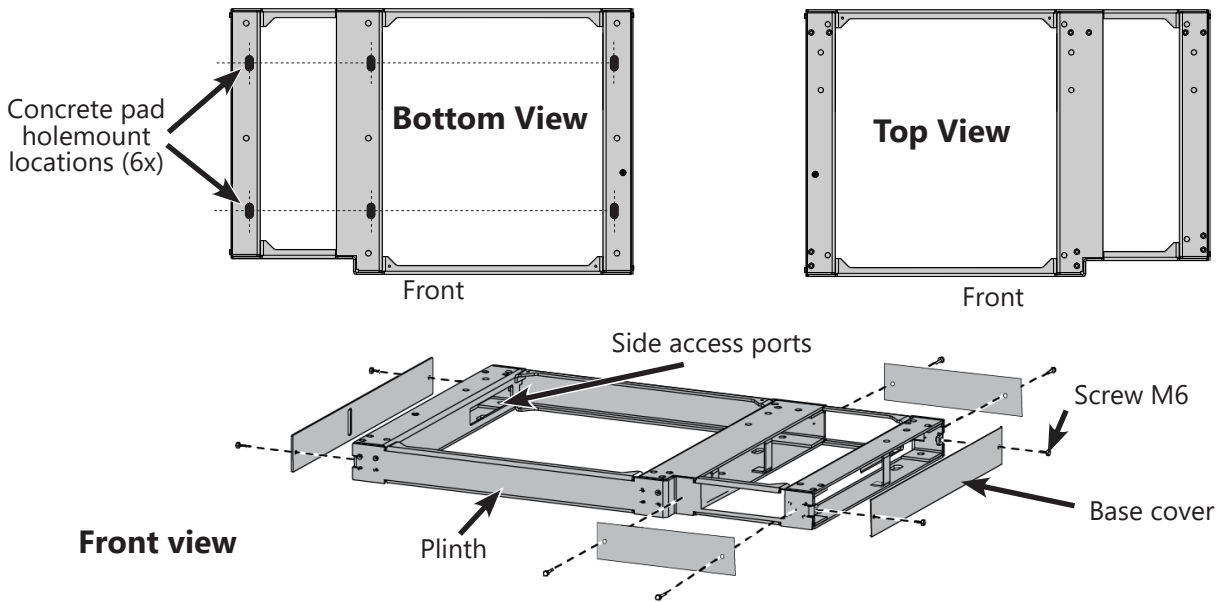

Figure 22. Plinth Mounting Footprint, Bottom and Top Views

2. Obtain bolts and washers from installation kit.
 - **Concrete Pad**—Thread bolts with washers into anchors or inserts, 1.5" bolts with 1/2" lock and flat washers, along with the rubber washers, Figure 23. Do not tighten bolts until all are in place.
 - **Vault**—Fasten cabinet to steel structure with customer provided 1/2" x 2.5" bolts, nuts, flat and lock washers, Figure 24.

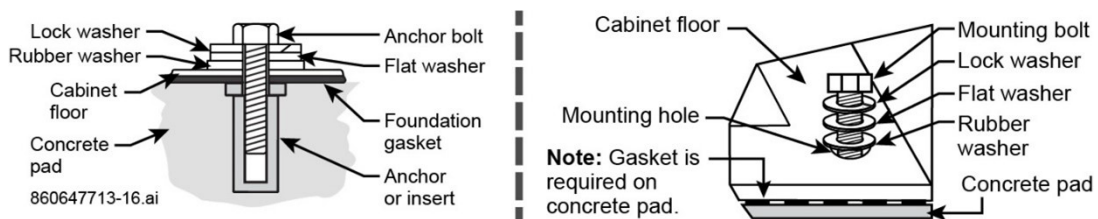

Figure 23. Fastening Cabinet to Concrete Pad

2.7 Route and Connect Cables

⚠ Important:

- A licensed electrician is to install all cabinet electrical connections conforming to NEC, state, and local codes. Properly ground all site equipment before making any electrical connections.
 - If routing cable through pad (structure), remove floor knockouts (punch outside to inside) before placing cabinet onto pad; Figure 18, Figure 19, Figure 24.
- Bring in cable through knockouts on left and right walls and cabinet base, Figure 24.
- Use door key to open and remove rear panel for cable access, Figure 8.
 - Use knockouts on cabinet topside only for stacking two cabinets (CommScope Telco AIO Cabinet only), Figure 25.
 - Apply Duct Seal on the top two glands used to route the fiber from the Equipment compartment to the FDH to ensure separate compartment environments.
 - Apply a bead of Duct Seal (if no foam seal is present) around the Cable entrance plate in the FDH.

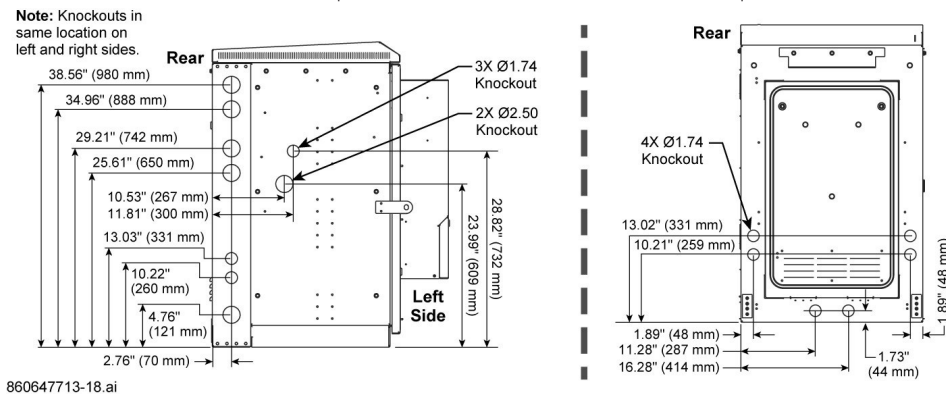

Figure 24. Cabinet Knockout Locations, CommScope Telco All-In-One Cabinet

2.8 Mounting The Cabinet On A Vault, or Fiberglass Sleeve

The FMS is a fiberglass and polymer concrete sleeve that may be used to support the cabinet at ground level. The FMS may also be used as a splicing vault. Four vertical cable racks are molded into the sides of the FMS to accommodate removable rungs (not provided). The rungs may be used to provide support for splice cases or OSP cable storage.

The large size FMS, shown in Figure 26, measures internally 48 x 60 inches (121.9 x 152.4 cm) and is 37.25 inches (94.6 cm) deep.

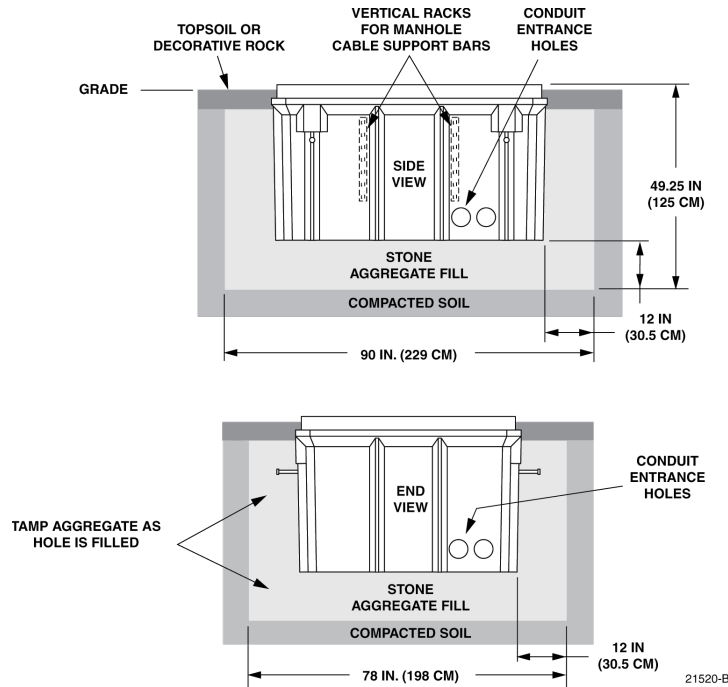

Figure 25. Large Fiberglass Mounting Sleeve (FMS-FD3J-KIT-B)

Installation Recommendations:

The site chosen for the installation must conform to all local codes and any permits require must be obtained prior to the start of installation. The location must be accessible and provide adequate parking for worker and vehicle safety. Situate the FMS close to the trench that was used for routing the OSP fiber cables for the network distribution system.

The installed cabinet must not create a visual or physical obstruction to vehicular or pedestrian traffic. Ensure that there is sufficient space on all sides to facilitate cabinet installation. Depending on the landscaping requirements, the top surface of the mounting sleeve may be located from 0 to 4 inches (10.2 cm) above the surrounding grade.

Excavation:

The excavation must be large enough to provide a fill base that will maintain stability for the FMS and the cabinet mounted on it. There must be room for 12 inches (30.5 cm) of fill below and on each side of the FMS. The excavation dimensions for the large FMS are shown in Figure 26.

Excavate a rectangular hole for the FMS.

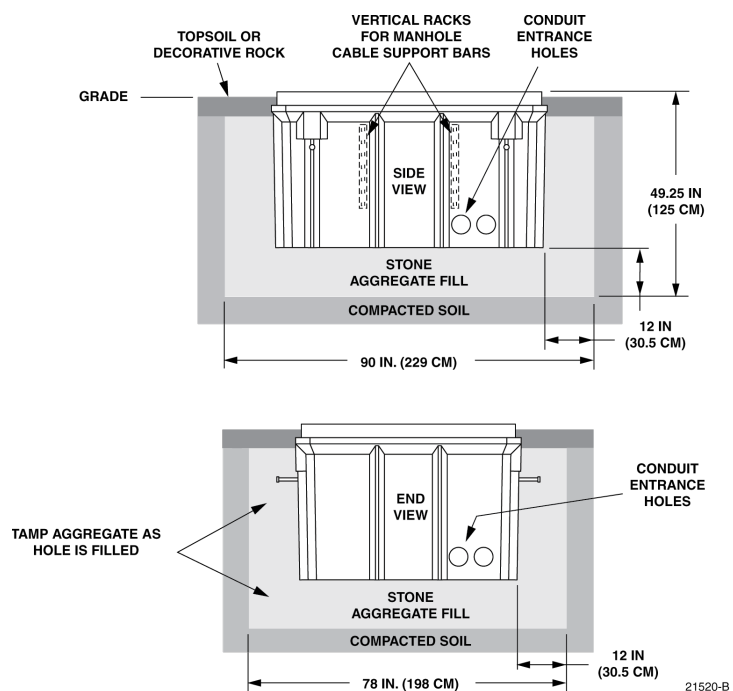

Figure 26. Excavation Recommendations for (FMS-FD3J-KIT-B)

Placement of the FMS:



Danger: Use adequate lifting equipment when installing the FMS. Do not stand in the hole while placing the FMS in position. An unexpected shift of the FMS could result in personal injury.

Use the following procedure to place the FMS into the excavation:

1. Fill the bottom of the hole with stone aggregate, tamping it as it is filled to build a 12-inch (30.5 cm) layer with a level surface. The stone aggregate will provide a stable base to support the FMS.

Note: Use crushed rock 3/8-inch or less in size mixed with stone dust (per local practice) to fill the hole. The name of the material may differ in different geographical areas. Possible names are Class 5, stone dust, aughts (0s) and ones (1s), or stone aggregate

2. Use appropriate lifting equipment to place the FMS into the center of the hole. Lifting bolts are provided
3. Use a carpenter's level to verify that the FMS is level. If it is necessary to add or remove fill for leveling, tamp any added fill to maintain the base stability.

Cable Conduit Installation:

Select the conduit entrance holes (see Figure 15) for the OSP feeder and distribution cables. If necessary, additional conduit entrance holes may be cut using a power drill and hole saw. Place and route the conduit into the entrance hole(s). If preferred, the FMS may be installed without conduit. OSP cables may be routed into the FMS at any point that is convenient. Cut the cable entrance hole to match the size of the cable.

Grounding System Installation:

Install a grounding system (not provided) that meets all local electrical codes. Check local codes for grounding system installation, use of clamps, wire size, and any other grounding requirements. Typically, #6 AWG copper wire is used for the grounding wire. Install the grounding system inside the FMS where it will not interfere with the conduit or cables. Leave sufficient slack in the grounding wire to allow it to be routed into the cabinet after the cabinet is mounted on the sleeve.

Back Fill:

If installing conduit, hand shovel stone aggregate under the conduit to avoid damage from the power tamper.

Complete the back fill as follows:

1. Add stone aggregate evenly around the FMS and tamp. Fill to approximately 6 inches (15.2 cm) from the top of the excavation.
2. Complete the back-fill with crushed rock or topsoil depending on the landscaping requirements. The top surface of the mounting sleeve may be located from 0 to 4 inches (10.2 cm) above the surrounding grade (see Figure 12).

Mounting the Cabinet on the FMS:

Use the 216B key tool to un-latch and latch the cabinet doors as needed during the mounting process.



Warning: Use appropriate lifting equipment when moving or installing the cabinet. Do not stand under a cabinet as it is being hoisted into position for mounting. A failure of the lifting equipment could result in serious personal injury.

Use the following procedure to mount the cabinet on the FMS:

1. Mount the FMS adapter cover on the FMS and secure using the two cap screws and flat washers provided. Tighten each cap screw securely.
2. Place the isolation gasket (provided with cabinet) on the adapter cover and align the holes in the gasket with the holes in the adapter cover. Make sure the wide side of the gasket is on the side of the adapter cover that corresponds to the front side of the cabinet.
3. The isolation gasket installed in step 4 should remain in place between the adapter cover and ground spacer. If a ground spacer will not be installed, proceed to step 8.
4. Secure the cabinet to the adapter cover using the eight cap screws, eight lock washers, and eight flat washers provided with the spacer. Tighten all cap screws securely.
5. Using appropriate lifting equipment, hoist the cabinet several feet into the air to provide access to the feeder and distribution cables



Danger: Do not stand directly under the cabinet as it is being hoisted into position for cable installation. A failure of the lifting equipment could result in serious personal injury

Note: Label or tag the stub end of each cable so it can be identified after it is routed to the splice enclosure.

6. Carefully route the stubbed feeder and distribution cables through the rectangular opening in the cover and into the vault.
7. Feed the stubbed feeder and distribution cables into the appropriate conduit sections and route to the splice enclosure (not provided). Some excess cable slack may be stored in the bottom of the vault.

Note: A separate splice enclosure (not provided) is required for splicing the cabinet OSP cables to network OSP cables. If required, splice enclosures may be mounted in the vault.

8. Secure the cabinet to the adapter cover or spacer using the eight cap screws, lock washers, and flat washers provided with the cover. Tighten all four cap screws securely.
9. Install the cover onto the FMS and secure using the two cap screws and washers provided. Tighten both cap screws securely.

Note: The vault cover may be installed at a later time to the interior of the vault to be accessed for cable installation, ground wire installation, or splicing.

10. Reinstall the left and right access covers that were removed in step 1. Use the 3/16-inch security hex-head wrench to tighten the screws that secure each access cover to the sides of the cabinet ground spacer/riser.

Grounding Wire Connection To Cabinet:

Prior to mounting the cabinet, a grounding system and grounding wire should have been installed (see Section 3.5) in the space below the cabinet.

2.9 Connect Cabinet to Main Earth Ground

Connect cabinet to earth ground with at least one ground lug at bottom rear of cabinet, Figure 27.

- Use a 2 AWG ground wire (customer provided) to site ground ring per local requirements.
- Ground external ancillary equipment to the 8-position ground bar located in the cabinet. The ground bar uses 1/4"-20 studs spread at .625" (15.875 mm) C-C, Figure 27.

Note: Use at least one ground lug to connect cabinet to main earth ground.

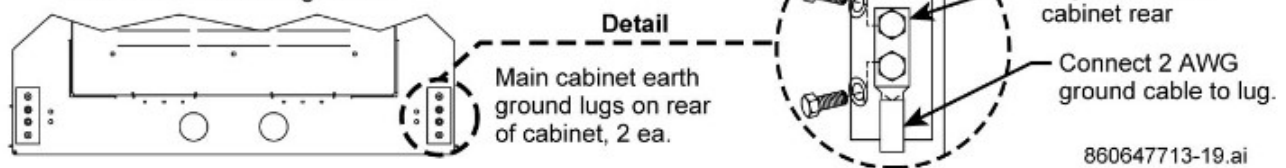

Figure 27. Main Earth Grounding

2.10 Connect Cabinet to Outgoing Office Alarms

Make sure to look at the cabinet SD for outgoing equipment and cabinet alarms to the alarm terminal block(s). The customer is responsible for outgoing alarms to a central office.

2.11 Connect Cabinet to Main Power Source, Turn-up

The customer shall provide an input voltage feed of 100V to 250V AC (full output power above 185V). The recommended feed is standard 240 V which plugs either directly into the AC load center or via the optional power meter input. From which power is branched to power and run all provided cabinet systems and equipment such as:

- Power distribution and rectification system
- Cabinet equipment connected to power system
 - DC light, fuse panels, overvoltage protection units, fiber panels, and remote monitoring units
- Cooling systems
 - Air conditioner
- AC electrical outlet (GFCI)
- An optional Eltek Power Plant is available with a max of 200Amps and mounts on a 2RU tray. Typical load at 50% at nominal input results in 148 BTU/hr and 43W draw per rectifier. Maximum load at 100% results in 409 BTU/hr and 120W draw. The optional configuration is wired to include two 1800W rectifiers resulting in a total of 3600W = 75 Amps @ 48VDC.

⚠ Important:

- A licensed electrician is to install all electrical connections conforming to NEC, state and local codes. Properly ground all site equipment before any electrical connections.
- AC feeds from an appropriate disconnect device to the cabinet must have surge protection and dedicated breakers. For all cabinet power connections and feeds, refer to the cabinet schematic drawing (SD) and equipment instruction manuals supplied with the cabinet.

Warning:

- Maintain and adhere to all local and state AC utility wiring and safety precautions. Failure to follow instruction can cause bodily harm, death, and equipment damage.
- Properly ground the cabinet to site earth ground for reliable earth ground of rack mounted equipment. Do not make any electrical connections prior to this.
- The power requirements must not exceed the marked ratings on the FCI outlet.
- Disconnect all power prior to servicing.

2.12 Power meter installation (optional)

Important:

- Structurally mounting power meters is dependent upon city electrical code/ordinances to determine if height requirements exist.
- A licensed electrician is to install all electrical connections conforming to NEC, state and local codes.

2.12.1 Structurally mounting:

Option 1 If the power meter can be mounted within the above-ground range of 31.05 to 44.79 inches, use the provided PEM mounts to attach it directly to the cabinet.

Option 2 : If the power meter needs to be mounted higher than 48 inches, use a power meter height extension accessory. This accessory works with the existing PEM supports to allow an above-ground mounting range of 48 to 62.75 inches.

Option 1:
above-ground range
31.05 to 44.79 inches

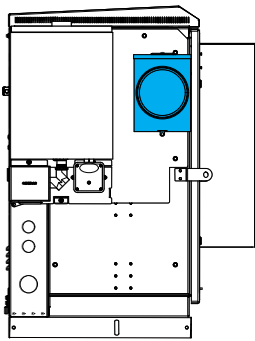

Option 2
above-ground range
48 to 62.75 inches

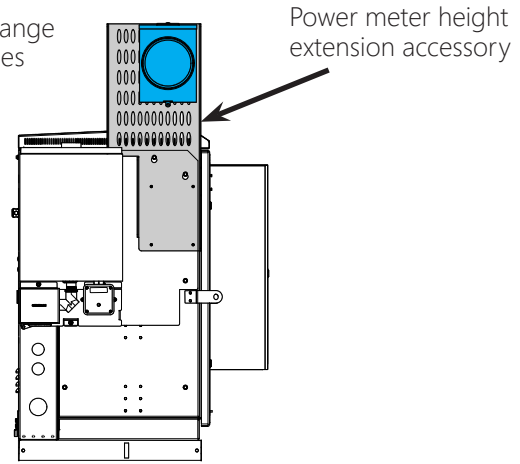

Figure 28. Structurally mounting power meters

Note: If neither of the above options are suitable, alternative mounting locations can be utilized. (Unistrut poles or other similar materials)

3 Cabinet Battery Installation

Danger:

- Batteries can be a lethal source of electrical power. Follow all locally approved safety practices.
- Do not wear metallic jewelry, nor allow any tools to rest on batteries or lay across terminals.
- Do not smoke, permit open flame, or cause sparks near a battery.
- Keep batteries upright, and do not lift batteries at the terminals.

Caution:

- Install batteries only after mounting the cabinet onto a concrete pad, steel plate or grate.
- Do not lift the cabinet with the batteries installed, which may damage the cabinet.
- Maximum amp hour per battery string should not exceed 190-amp hours.
- There is risk of explosion if you replace one battery type with another. Dispose of used batteries as instructed by the battery manufacturer.
- Do not connect fewer batteries to a battery string than required, as thermal runaway can occur.
- If battery storage temperature exceeds 32 C (90 F), the battery open circuit time should not exceed four months.
- Follow all battery and cabling instructions to reduce risk of fire, electric shock, and injury.

Important Safety Precautions:

- For only one battery string, CommScope recommends loading battery shelf #1 first.
- The customer shall incorporate a containment system within the battery compartment of the cabinet to capture electrolyte in the case of a flooded battery.
- Wear full eye protection and protective clothing.
- If electrolyte contacts the skin, wash it off immediately with water.
- Wash down spilled electrolyte with a suitable acid neutralizing agent.

Note: A usual practice is to apply a solution of about one pound (500 grams) bicarbonate of soda to one gallon (4 liters) of water. Carefully pour (add) the bicarbonate solution of soda onto spilled electrolyte until evidence of reaction (foaming) ceases. Flush the resulting liquid with water and allow area to dry.

3.1 Battery Safety Recommendations

- Always wear eye protection when installing and removing batteries. If exposed to electrolyte, immediately soak eyes with plenty of water and seek medical attention as soon as possible.
- Always keep water available for rinsing and washing.
- For skin protection, wear protective clothing such as, rubber gloves and long sleeves, including safety glasses (or a face shield).
- For protection of clothing, wear rubber or plastic aprons or other appropriate protection.
- Keep batteries upright to prevent spillage.

Note: In case of spillage do not dispose of electrolyte in public drainage systems. Use an appropriate absorbent material to remove electrolyte. Refer to the MSDS for procedure guidelines and consult with the manufacturer representative for available spill kits.

- Always keep battery covers in place prior to installation.
- Use a multimeter to verify polarity when connecting string to the system. Never rely on color. Color-coded battery terminals and color-coded system wires are not always polarity compatible.
- Always ground yourself, your tools, or anything else when working on batteries to prevent accidental sparks from static electric discharge.
- Take extra care to prevent static electricity during days of low humidity. Touch the outside of the cabinet, or any grounded metal structure to eliminate static electric discharge.
- Use the battery handles when lifting batteries. Batteries are heavy, handle and lift appropriately.
- Apply corrosion preventative compound (NOOX) generously and completely for all connections made during installation as recommended by the battery manufacturer.
- Never substitute unapproved parts.

3.2 Required Tools

Only use insulated tools to install batteries.

- Socket wrench set, metric
- Socket wrench extension
- Open end wrench set, metric
- Allen wrench set, metric
- Voltmeter
- NOOX

3.3 Recommended Battery Dimensions and Battery Tray Configurations



Caution: *Dispose of used batteries as specified by the battery manufacturer or in the instruction manual with the battery kit and per local or regional practice.*

Use only UL approved VRLA batteries, that meet the lower explosive UL requirement in agreement with the battery manufacturers product instruction manual.

3.4 Maximum Battery Dimensions

- Height – 12.3"
- Width – 5.3" per battery (max string width not to exceed 21.44", or 5.3" x 4)
- Depth – 22.1" (do not exceed this depth)

Apply battery dimensions as required toward use of battery tray design in the CMC cabinet.

3.5 7RU Battery Tray Spacing Options – Battery Recommendations

CommScope Telco All-In-One Cabinet Equipment and Battery Cabinets (mixed) – 7RU Spacing Options

- 7RU Battery Recommendations:
 - 170 AH – 1x string of 4x 48V DC VRLA batteries

3.6 Battery Voltage and Battery Supply Resistance

Nominal battery system circuit voltage, float (charging) voltage, and battery supply resistance is in accordance with PS E.1.6.100.1 where the:

- Nominal battery system circuit voltage is -48 VDC
- Nominal float (charging) voltage is -54.5 VDC
- Total battery supply resistance of all battery strings is 5.33 Ohms

Use the information in this section to calculate the maximum short circuit current in the final installation.



Caution:

- The design of this equipment allows it to connect to a battery source of nominal 48 VDC based on 2 V per cell with a minimum resistance of 0.5 mΩ.
- This resistance calculation includes the minimum battery system equivalent parallel resistance and the interconnecting conductors to the input termination point of this equipment.
- Use these values to verify you do not exceed the DC short circuit current withstand rating of the equipment and that the overcurrent protection devices have the required interrupting capability.
- Field installed or replaceable components that intentionally interrupt output short circuit current shall have a specified interrupt rating of 10 kA.

3.7 Battery System Resistance and Short Circuit Current Calculation

To calculate the battery system resistance and short circuit current for this cabinet as given in PS-E.1.6.100.1 of IEC61204-7 use the following:

- **Battery String Resistance Calculation (per string)**

$$R_{Str1} = (4 \times R_b) + (3 \times R_{bc}) + R_{sc-} + R_{sc+}$$

Where:

R_b - Battery resistance

R_{bc} - Resistance of battery links

R_{sc-} - Negative string cable

R_{sc+} - Positive string cable

- **Total Resistance of All Strings**

$$R_{Tstr} = \frac{1}{(R/R_{str1}) + (R/R_{str2}) + (R/R_{str3})}$$

And:

$$SCCR = \frac{V_{Batt Supply}}{R_{Tstr}}$$

3.8 Battery Installation

Battery installation consists of:

Step 3.8.1 – Cabinet Preparation Prior to Installation, VRLA

Step 3.8.2 – VRLA Battery Installation

3.8.1 Cabinet Preparation Prior to Installation, VRLA

Prior to installing VRLA batteries:

1. Open the door and verify cabinet connection to site ground.
2. For initial cabinet installation, ensure all cabinet power is **OFF**, including the power shelf.
3. Remove the battery front retainer bracket, Figure 29.
4. Take off the four M6 screws on left and right sides of the bracket and retain hardware for reinstallation.

Note: If cabinet configuration uses Anderson connectors, remove string bus connector from bracket and retain hardware for reinstallation; Figure 29, Figure 30. For standard lug connection to +RTN and -48 V terminals (Figure 32), set cables clear of batteries and do not remove protective covers until ready to connect.

5. Cover the door gasket on the lower door flange to protect it from any damage, Figure 29.

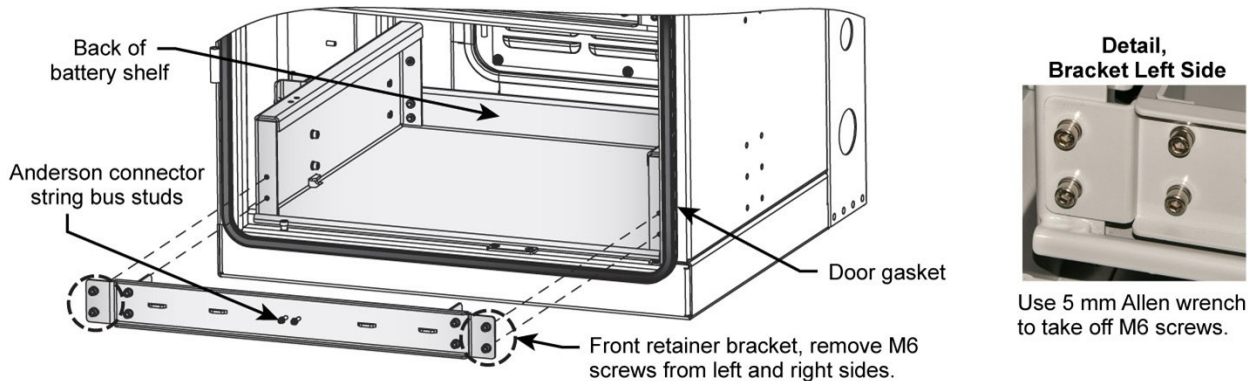

Figure 29. Front Battery Retainer Bracket Removal, VRLA Installation

3.8.2 VRLA Battery Installation



Important:

- Do not remove protection boots from the batteries and battery cables until ready to connect.
- terminate each cable to correct terminal. Cable connectors have marked polarities and color codes; red on positive cable (+RTN), black on negative cable (-48 V).
- Have the SD on hand to look at for battery and thermal probe connection details.
- If installing batteries in a battery only cabinet also follow instruction on routing and connection to a CommScope Telco All-In-One Cabinet using battery interconnect kit 860651309 in the next section **Installation - Battery Interconnect Kit - CMC**

To install VRLA batteries:

1. Read the voltage for each battery, at least 12.5 VDC or higher. If reading is less than 12.5 VDC, consult manufacturer. DO NOT install batteries that measure less than 12.5 VDC.
2. Read and follow the manufacturer's instruction on battery installation (customer provides kit). Installation may require more than one string of batteries.

Note: Do not apply charging if battery string measures less than 50.0 VDC.

3. Install busbars (jumpers) per Figure 30 from battery kit to configure one -48 VDC string.

4. Place busbars (+ to -) between batteries #1 and #2, #2 and #3, #3 and #4 per Figure 30.
5. Install a thermal probe to the negative terminal of battery #3 for the string, Figure 30.

Note: Seat thermal probe between busbar, flat washer, and nut of per Figure 30. Refer to the SD if installing more than one string of batteries.

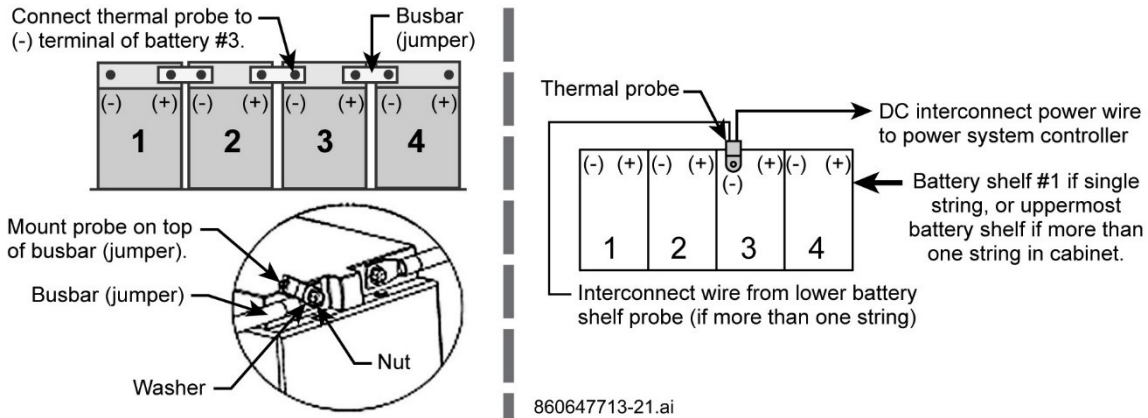

Figure 30. Example of Battery Busbar and Thermal Probe Connections

6. Repeat steps 1-4 to install additional strings in the cabinet.
- **For Anderson connectors** – do not fasten string connector until after installing all strings.
- **For standard lug connections** – do not connect string to circuit breaker or master busbar until after installing all strings.
7. Connect battery string cables from battery string connector. Do not remove protective cover from each cable end until ready to connect to the -48V and +RTN string terminals.
8. Locate battery cable marked **BATT+**. Remove protective lug cover and connect it to positive (+RTN) terminal of right-most battery per Figure 31 or Figure 32.
9. Locate battery cable marked **BATT-**. Remove protective lug cover and connect it to negative (-48V) terminal of left-most battery per Figure 31 or Figure 32.

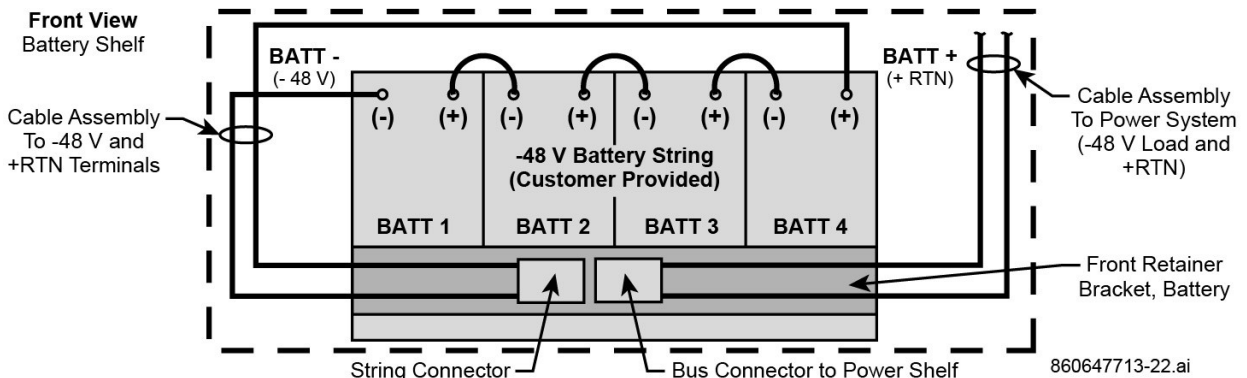

Figure 31. Battery String Cable Connection, Example Using Anderson Connectors

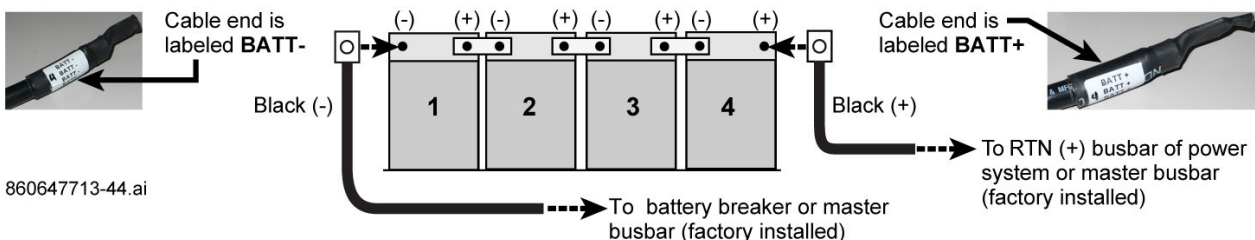

Figure 32. Battery String Cable Connections, Example with Lugs

10. Dress the battery cables and thermal probe wires as required.
11. Reinstall the battery front retainer bracket on each shelf, Figure 29.
12. If using Anderson connectors: Fasten string bus connector (to power system) onto retainer bracket per Figure 32; then fasten battery string connector to battery string bus connector.
13. Remove all installation debris, tools, and extra hardware from inside the cabinet.
14. Make sure you can close and open the door without any interference from battery cables.
15. Turn-up power and configure power system controller for VRLA batteries and total number of strings.

4 Appendix

Note: See appendix images 1-6.

4.1 Appendix Image 1

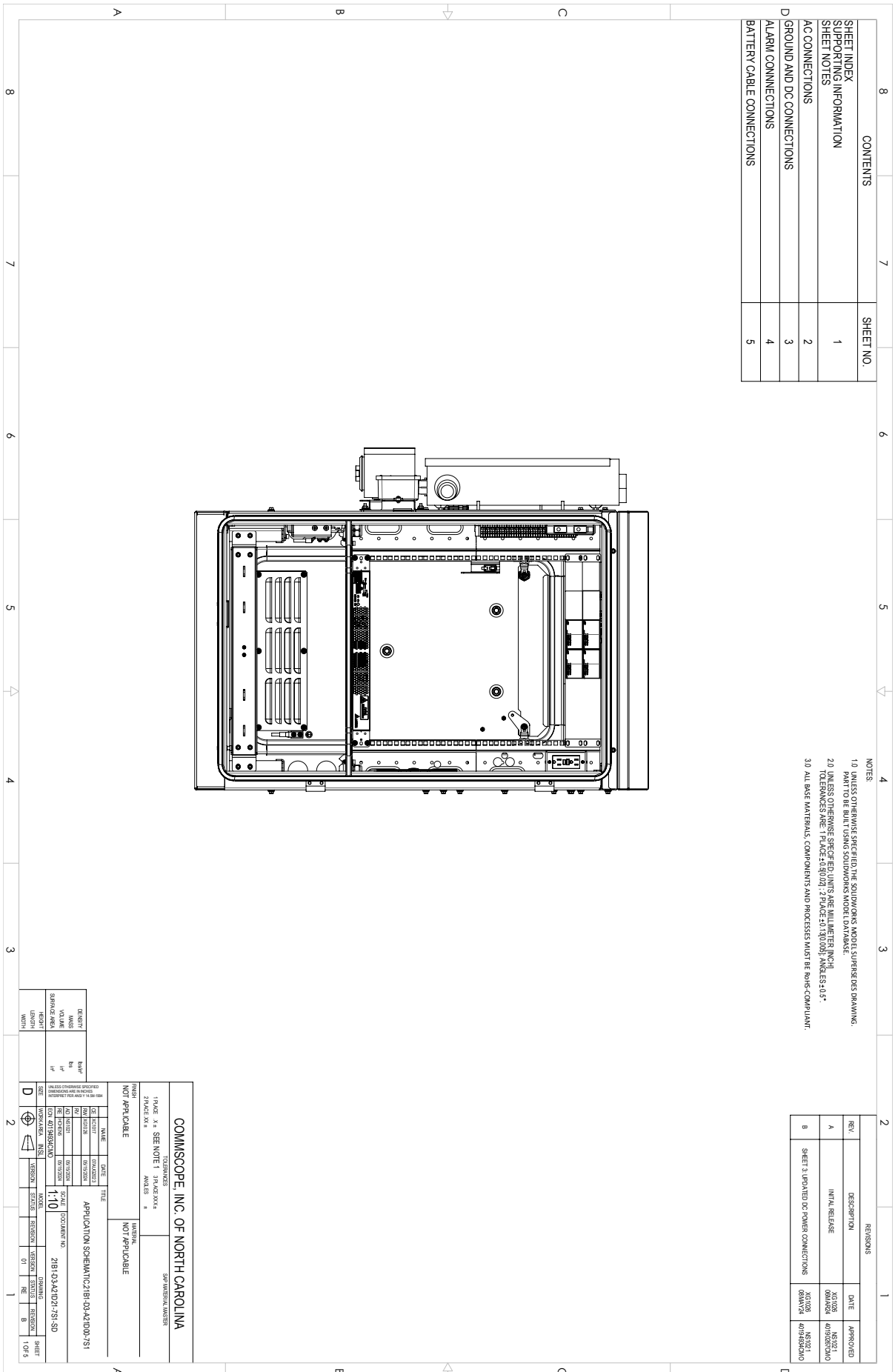

4.2 Appendix Image 2

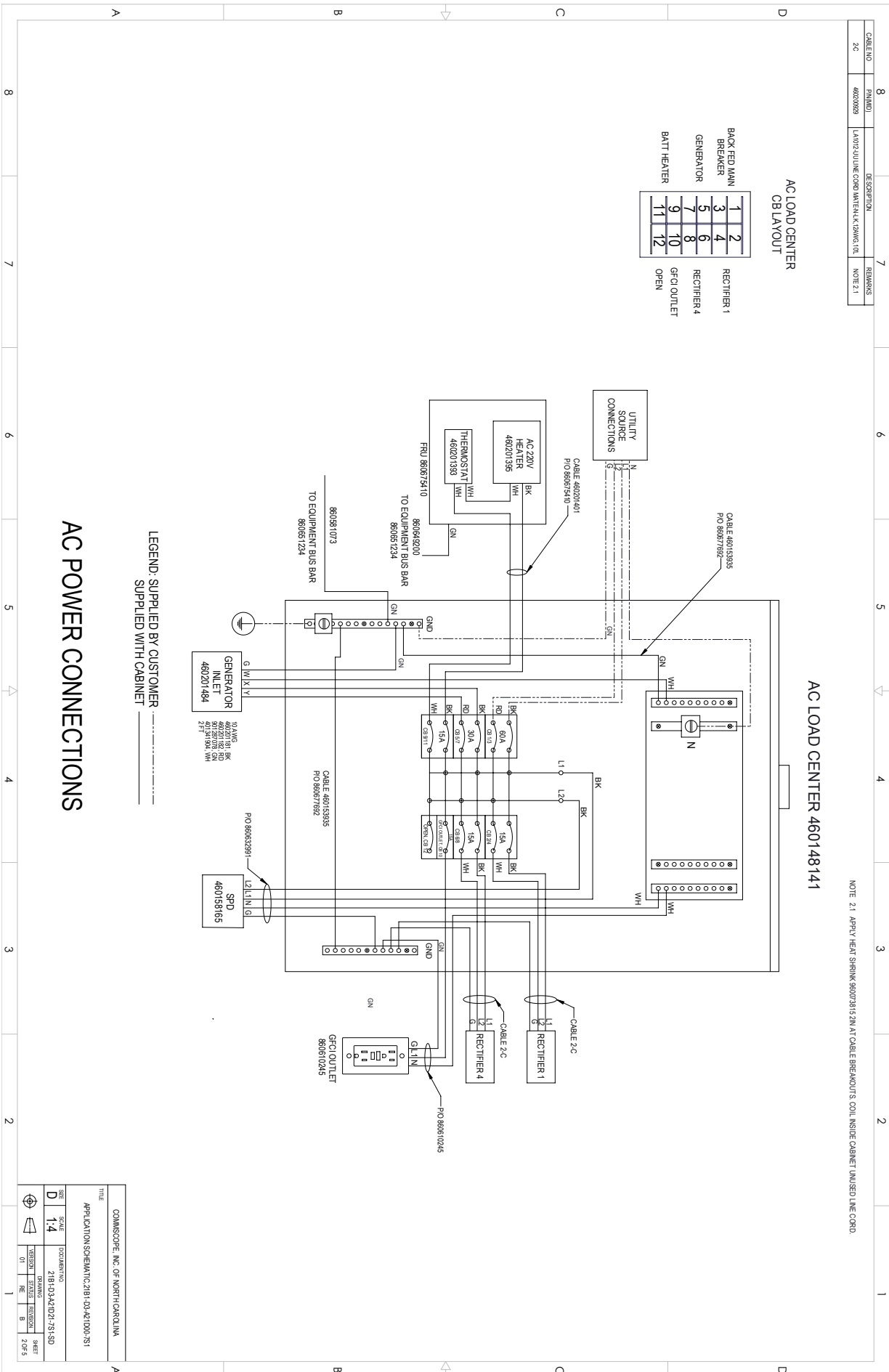

CABLE NO	NAME	DESCRIPTION	REMARKS
2C	46201461	LA1012 UTILITY CORP WAREHOUSE, 101	NOTE 2.1

BACK FED MAIN BREAKER	RECITFER 1
1	2
3	4
5	6
7	8
9	10
11	12

RECITFER 4
GFCI OUTLET
OPEN

AC POWER CONNECTIONS

LEGEND: SUPPLIED BY CUSTOMER
SUPPLIED WITH CABINET

TITLE		COMMSCOPE, INC. OF NORTH CAROLINA	
APPLICATION		SCHEMATIC	
SCALE	DATE	DESIGNED BY	REVISION
1:1	2/18/2024	2/18/2024	2/18/2024
DRAWN BY		CHECKED BY	
2045		2045	

NOTE 2.1 APPLY HEAT SHRINK 860739152M AT CABLE BREAKOUTS COIL INSIDE CABINET (UNUSED) LINE CORO.

4.3 Appendix Image 3

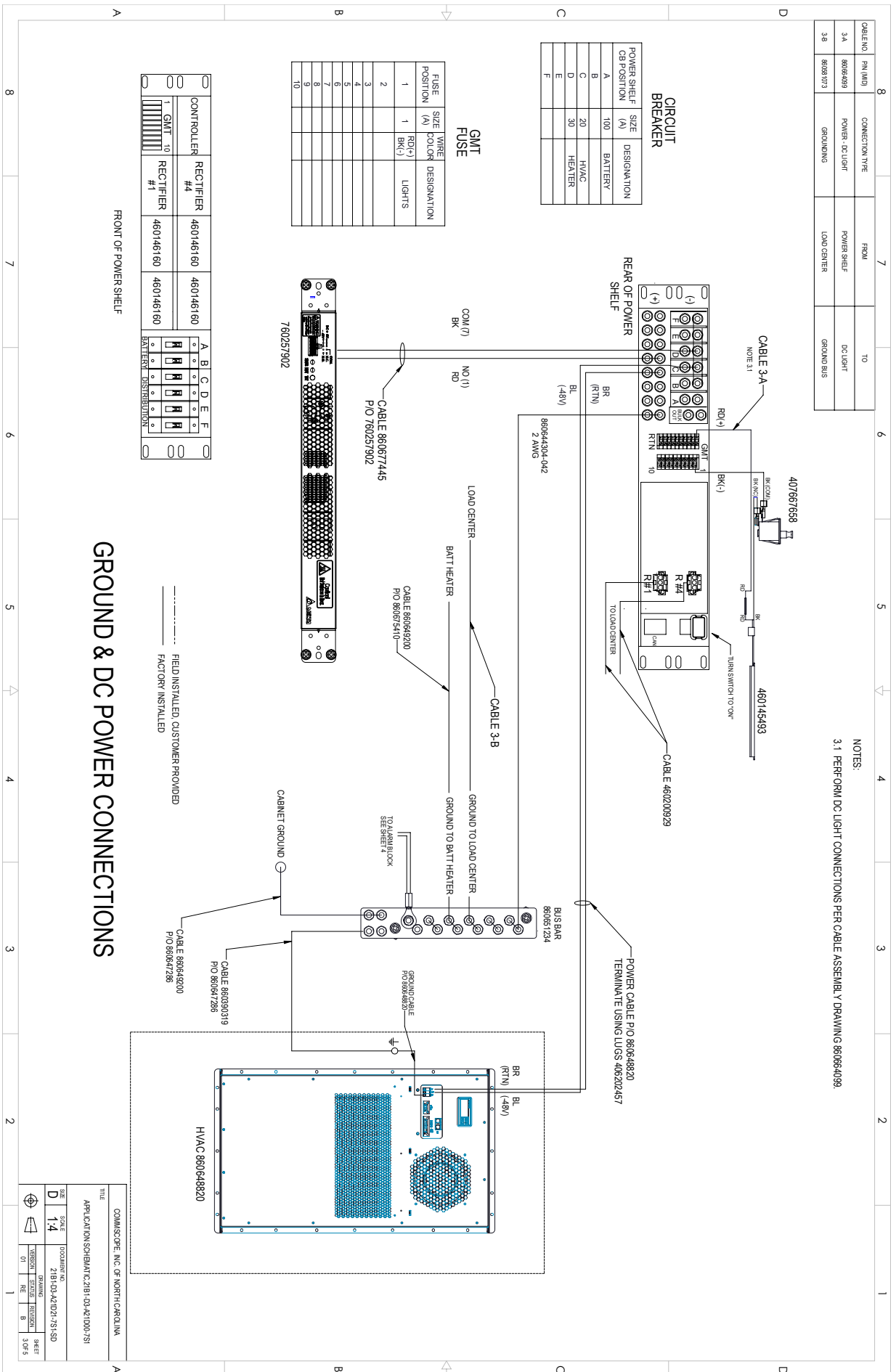

4.4 Appendix Image 4

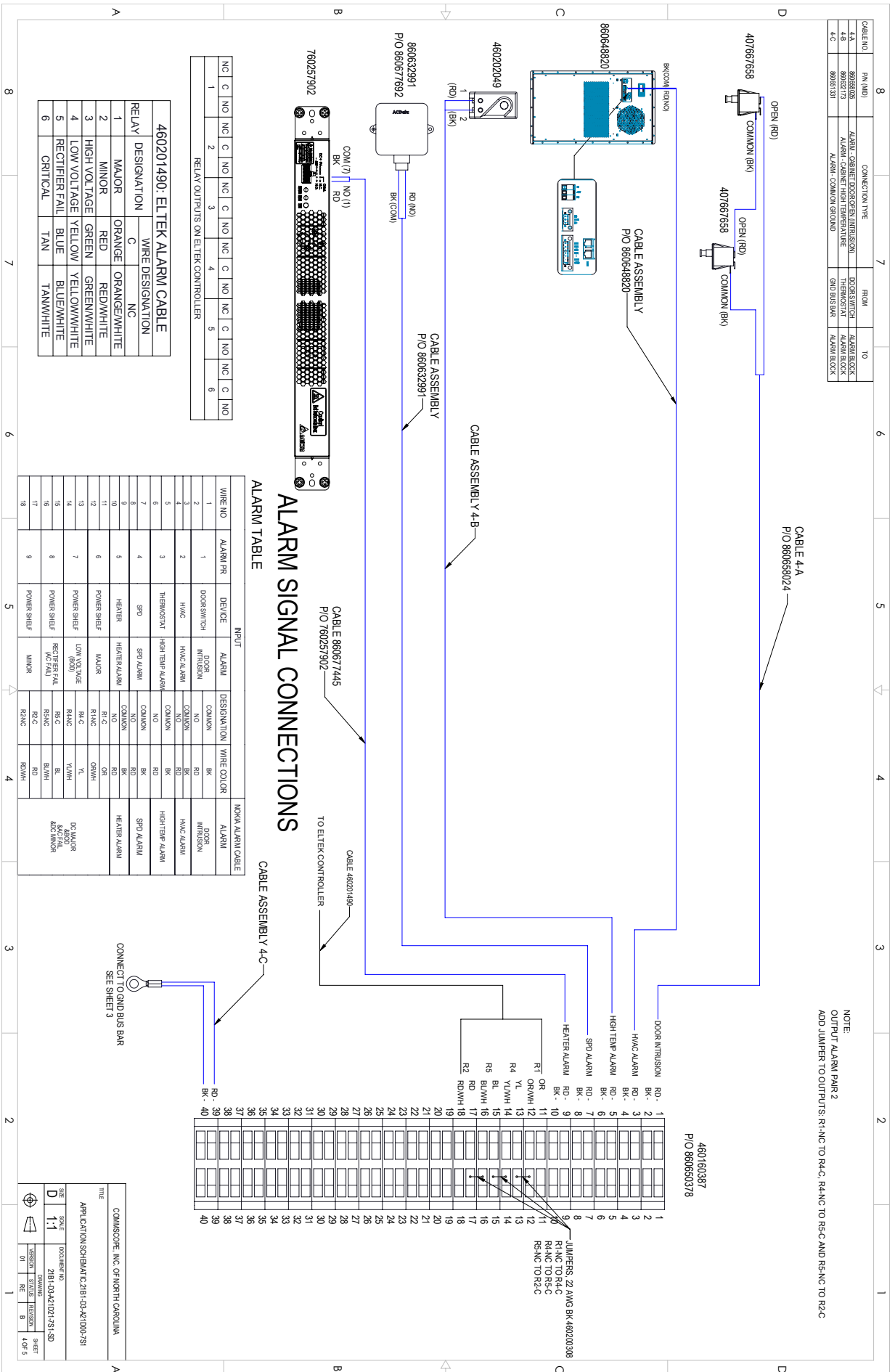

4.5 Appendix Image 5

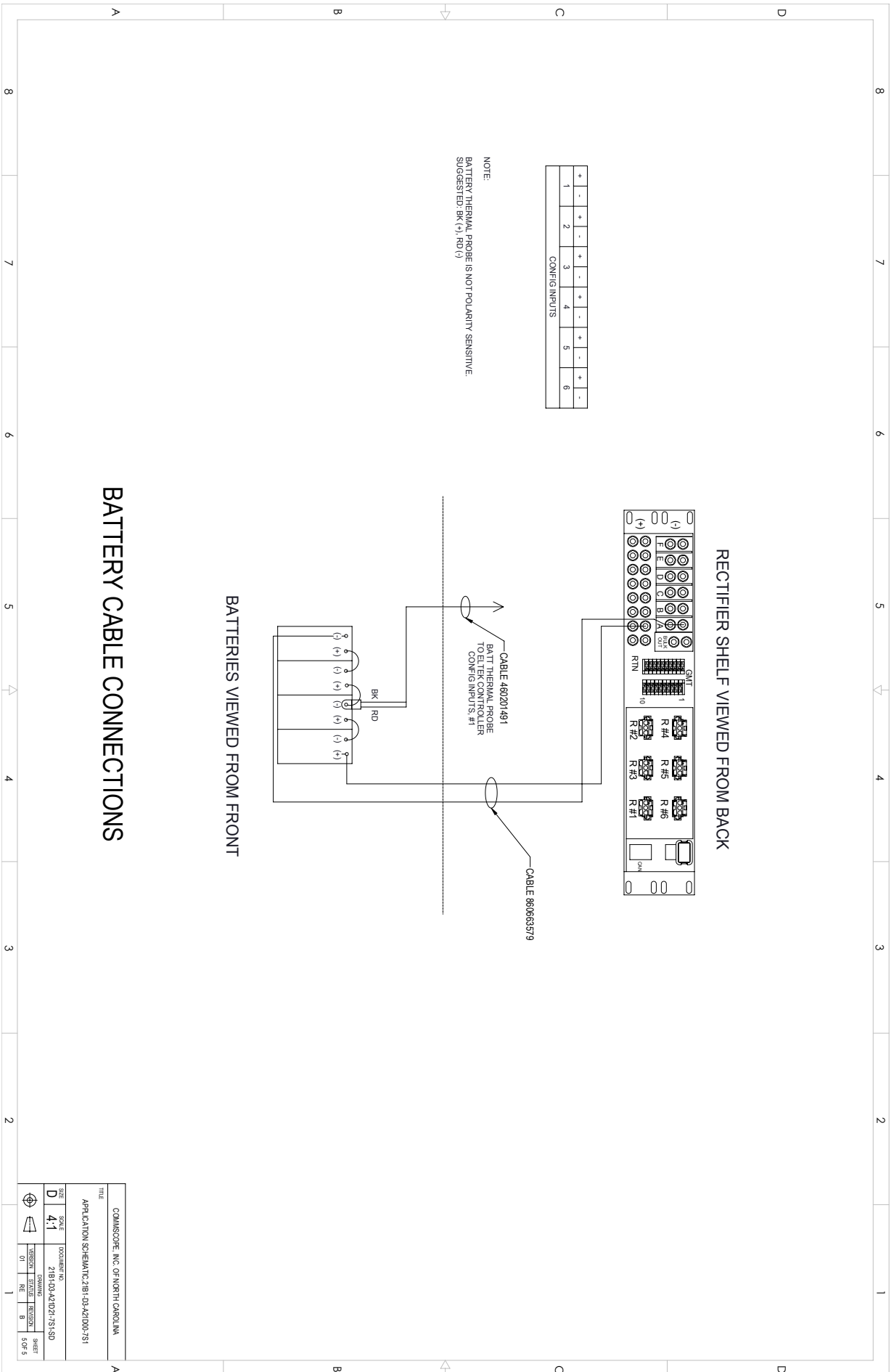

5 Disclaimer

All trademarks identified by ® are registered trademarks in the US and may be registered in other countries. All third-party product names, trademarks and registered trademarks are property of their respective owners. This product may be covered by one or more U.S. patents or their foreign equivalents. For patents, see www.cs-pat.com. This document is not intended to modify or supplement any specifications or warranties relating to CommScope products or services.

6 Contact Information

Visit our website or contact your local CommScope representative for more information. www.commscope.com
For technical assistance, customer service, or to report any missing/damaged parts, visit us at:
<http://www.commscope.com/SupportCenter>