

HX10-13W

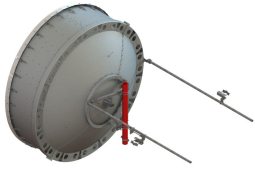

3.0m | 10ft ValuLine® High Performance, High XPD Antenna, dual-polarized, 12.200 – 13.250 GHz

Product Classification

Product Type Microwave antenna

General Specifications

Antenna Type HX - ValuLine® High Performance, High XPD Antenna, dual-polarized

Polarization Dual

Side Struts, Included 2

Side Struts, Optional 3

Dimensions

Diameter, nominal 3.0 m | 10 ft

Electrical Specifications

Operating Frequency Band 12.200 – 13.250 GHz

Gain, Low Band 48.5 dBi

Gain, Mid Band 48.8 dBi

Gain, Top Band 49.2 dBi

Boresite Cross Polarization Discrimination (XPD) 33 dB

Front-to-Back Ratio 76 dB

Beamwidth, Horizontal 0.6 °

Beamwidth, Vertical 0.6 °

Return Loss 26 dB

VSWR 1.1

Radiation Pattern Envelope Reference (RPE) 7421

Electrical Compliance ACMA FX03_13a | ETSI 302 217 Class 3 | US FCC Part 101A

Cross Polarization Discrimination (XPD) Electrical Compliance ETSI EN 302217 XPD Category 2

Mechanical Specifications

HX10-13W

Compatible Mounting Pipe Diameter	115 mm 4.5 in
Fine Azimuth Adjustment Range	±5°
Fine Elevation Adjustment Range	±5°
Wind Speed, operational	180 km/h 111.847 mph
Wind Speed, survival	200 km/h 124.274 mph

HX10-13W

Antenna Dimensions and Mounting Information

USX10



Dimensions in inches (mm)						
Antenna Size, ft (m)	A	B	C	D	E	F
10 (3)	8.0 (203)	22.5 (572)	125.0 (3174)	38.6 (980)	71.1 (1807)	10.3 (262)

Wind Forces at Wind Velocity Survival Rating

Axial Force (FA)

18800 N | 4,226.409 lbf

Angle α for MT Max

-130 °

Side Force (FS)

-6560 N | -1,474.747 lbf

Twisting Moment (MT)

-10725 N-m | -94,924.25 in lb

Force on Inboard Strut Side

9500 N | 2,135.686 lbf

Force on Outboard Strut Side

3350 N | 753.11 lbf

Zcg without Ice

618 mm | 24.331 in

Zcg with 1/2 in (12 mm) Radial Ice

744 mm | 29.291 in

HX10-13W

Weight with 1/2 in (12 mm) Radial Ice

466 kg | 1,027.353 lb

HX10-13W

Wind Forces at Wind Velocity Survival Rating Image

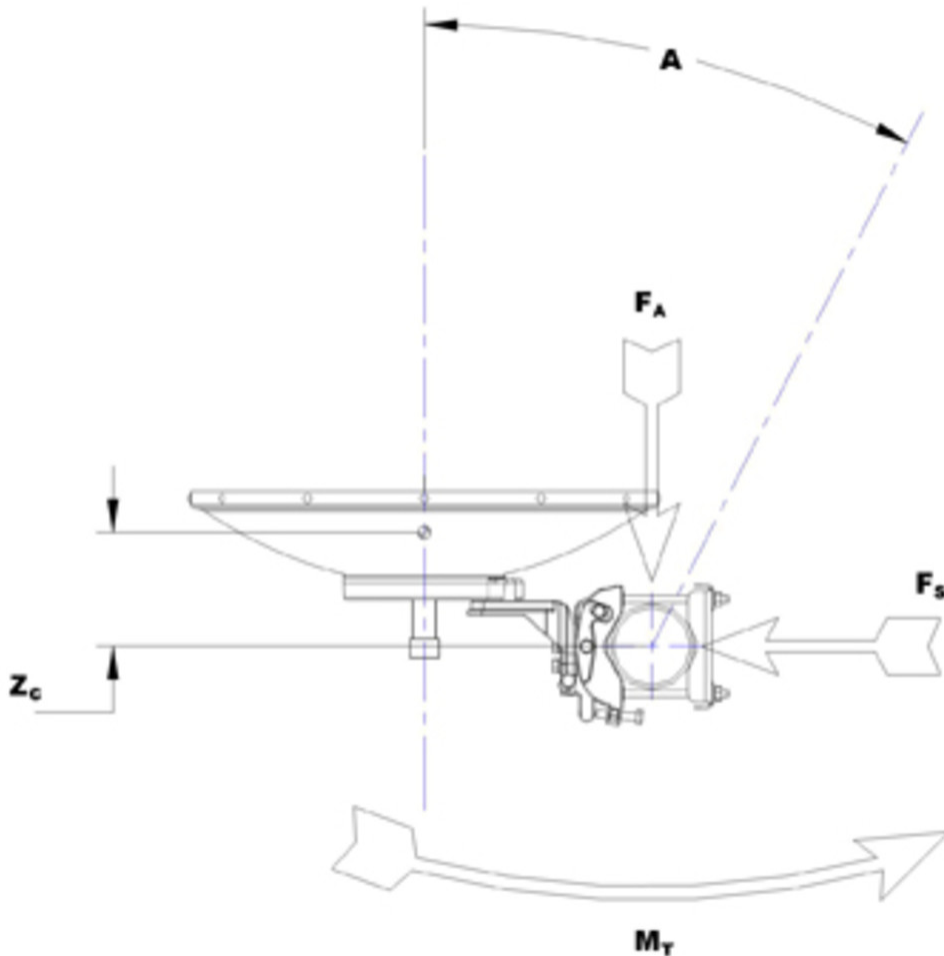

Packaging and Weights

Weight, net

263 kg | 579.815 lb

* Footnotes

Operating Frequency Band

Bands correspond with CCIR recommendations or common allocations used throughout the world. Other ranges can be accommodated on special order.

Gain, Mid Band

For a given frequency band, gain is primarily a function of antenna size. The gain of Andrew antennas is determined by either gain by comparison or by computer integration of the measured antenna patterns.

Boresite Cross Polarization Discrimination (XPD)

The difference between the peak of the co-polarized main

HX10-13W

Front-to-Back Ratio

beam and the maximum cross-polarized signal over an angle twice the 3 dB beamwidth of the co-polarized main beam.

Denotes highest radiation relative to the main beam, at $180^\circ \pm 40^\circ$, across the band. Production antennas do not exceed rated values by more than 2 dB unless stated otherwise.

Return Loss

The figure that indicates the proportion of radio waves incident upon the antenna that are rejected as a ratio of those that are accepted.

VSWR

Maximum; is the guaranteed Peak Voltage-Standing-Wave-Ratio within the operating band.

Radiation Pattern Envelope Reference (RPE)

Radiation patterns define an antenna's ability to discriminate against unwanted signals. Under still dry conditions, production antennas will not have any peak exceeding the current RPE by more than 3dB, maintaining an angular accuracy of $\pm 1^\circ$ throughout

Cross Polarization Discrimination (XPD) Electrical Compliance

The difference between the peak of the co-polarized main beam and the maximum cross-polarized signal over an angle twice the 3 dB beamwidth of the co-polarized main beam.

Wind Speed, operational

For VHLP(X), SHP(X), HX and USX antennas, the wind speed where the maximum antenna deflection is 0.3 x the 3 dB beam width of the antenna. For other antennas, it is defined as a deflection is equal to or less than 0.1 degrees.

Wind Speed, survival

The maximum wind speed the antenna, including mounts and radomes, where applicable, will withstand without permanent deformation. Realignment may be required. This wind speed is applicable to antenna with the specified amount of radial ice.

Axial Force (FA)

Maximum forces exerted on a supporting structure as a result of wind from the most critical direction for this parameter. The individual maximums specified may not occur simultaneously. All forces are referenced to the mounting pipe.

Side Force (FS)

Maximum side force exerted on the mounting pipe as a result of wind from the most critical direction for this parameter. The individual maximums specified may not occur simultaneously. All forces are referenced to the mounting pipe.

Twisting Moment (MT)

Maximum forces exerted on a supporting structure as a result of wind from the most critical direction for this

HX10-13W

parameter. The individual maximums specified may not occur simultaneously. All forces are referenced to the mounting pipe.