

THIS DRAWING IS UNPUBLISHED. RELEASED FOR PUBLICATION
 © 2016 COMMScope, INC. CONFIDENTIAL NOTICE: THESE DRAWINGS AND SPECIFICATIONS ARE THE PROPRIETARY PROPERTY OF COMMScope, INC. AND MAY BE USED ONLY FOR THE SPECIFIC PURPOSE AUTHORIZED IN WRITING BY COMMScope, INC.

REVISIONS				
P	LTR	DESCRIPTION	DATE	APVD
0		RLSD; NPR NSD00-047	17JUL2000	LS SH
A		REV; EC 0B40-0312-01	04DEC01	GG SH
B		REV; ECO-10-002359	04FEB2010	GG SH
C		REV PER BNS_CD_BRAND	09FEB2017	GG DC

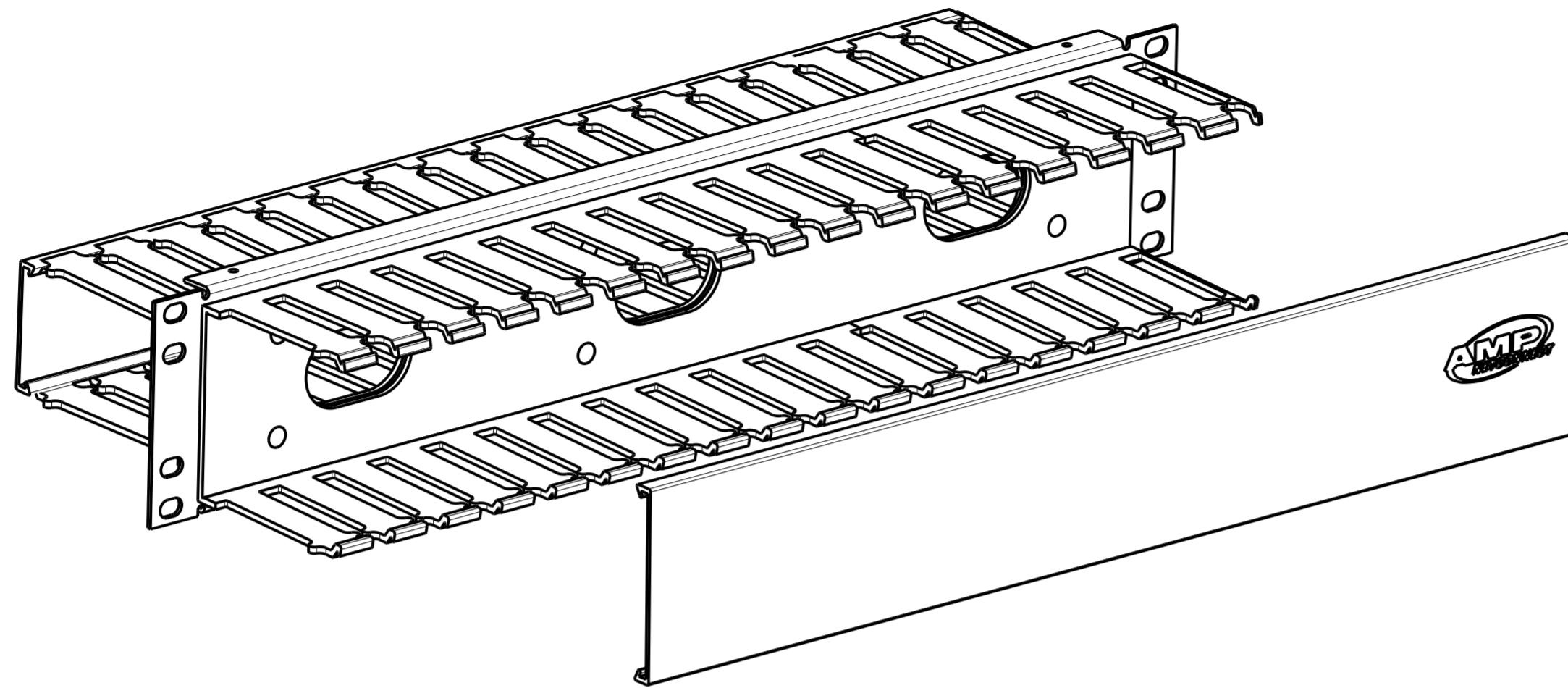

- 1. MATERIAL: MATERIAL: ASSEMBLY - BLACK POWDER COAT CARBON STEEL, AND PVC, BLACK, MATTE FINISH.
- 2. ALL DIMENSIONS ARE NOMINAL UNLESS OTHERWISE NOTED.

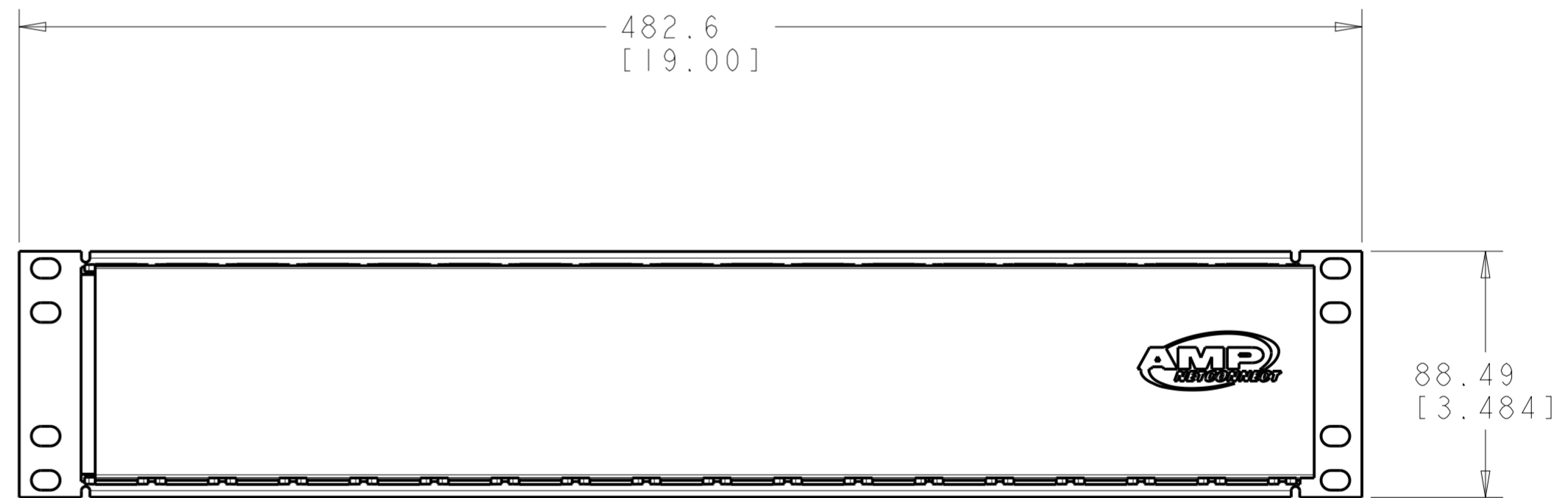
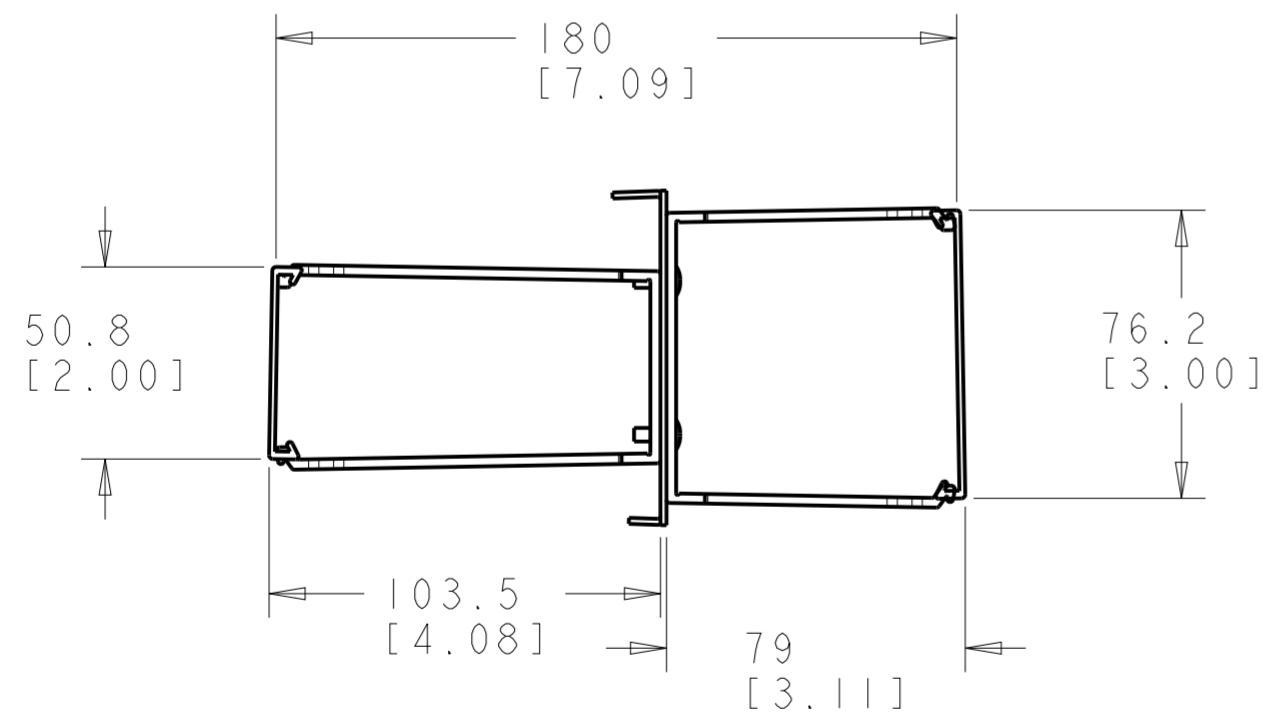

511.18 [20.125]	1375158-2
438.15 [17.25]	1375158-1
FRONT COVER LENGTH	PART NUMBER

THIS DRAWING IS A CONTROLLED DOCUMENT.		DWN L SMITH 09-FEB-2017	COMMScope, INC.	
DIMENSIONS: INCHES		CHK S. HERNDON 19 JUL 2000		
TOLERANCES UNLESS OTHERWISE SPECIFIED:		APVD B. DAVIS 19 JUL 2000	NAME PANEL, CABLE MANAGEMENT, 3.5 D, FRONT AND REAR	
0 PLC ±		PRODUCT SPEC -	SIZE A2	
1 PLC ±		APPLICATION SPEC -	CAGE CODE C-1375158	
2 PLC ±		WEIGHT -	DRAWING NO. 1375158	
3 PLC ±		CUSTOMER DRAWING	RESTRICTED TO -	
4 PLC ±		SCALE 1:2	SHEET 1 OF 1	
ANGLES ±			REV C	
FINISH -				