

ITEM	PART NO.	DESCRIPTION	CS-B QTY.	CS-B-2 QTY.	CS-B-A QTY.	CS-B-R2 QTY.	CS-B-R6 QTY.	WEIGHT
1	CS-B	CLUSTER SUPPORT BRACKET, LARGE	1	1	1	1	1	3.68 LBS
2	GUB-3244	3/8" X 2-1/2" X 4" GALV U-BOLT	-	1	-	-	-	0.31 LBS
3	MT515	ANGLE ADAPTOR	-	-	1	-	-	1.87 LBS
4	SWL-03	3/8" SS LOCK WASHER	-	-	1	-	-	0.09 LBS
5	SB-0306	3/8" X 3/4" SS BOLT KIT	-	-	1	-	-	0.04 LBS
6	SSTB2550H	HARDWARE KIT (ITEMS 8-13)	-	-	-	1	-	
7	CSBLR6H	HARDWARE KIT (ITEMS 8-11, 14-15)	-	-	-	-	1	
8	GB-04105	1/2" X 1" GALV BOLT KIT	-	-	-	1	1	0.11 LBS
9	GWF-03	3/8" GALV FLAT WASHER	-	-	-	6	6	0.02 LBS
10	GWL-03	3/8" GALV LOCK WASHER	-	-	-	4	4	0.09 LBS
11	GN-03	3/8" GALV HEX NUT	-	-	-	6	6	0.33 LBS
12	SS2550.01	STAR SUPPORT CLAMP	-	-	-	2	-	1.89 LBS
13	GD03950	3/8" X 9-1/2" GALV THREADED ROD	-	-	-	2	-	0.30 LBS
14	SS6080.01	STAR SUPPORT TEE BRACKET	-	-	-	-	2	2.51 LBS
15	TLSA6080.03	3/8" X 14" GALV THREADED ROD	-	-	-	-	2	0.44 LBS

REVISIONS				
REV.	ZONE	DESCRIPTION	BY	DATE
A		INITIAL RELEASE	TDM	11/25/98
B		CHANGE U-BOLT TO GUB-3244	-	06/15/99
C		REPLACE AA-U WITH MT515	-	03/26/01
D		REVISED AND REDRAWN	DMW	05/14/01
E		REPLACE SB-0306-S WITH SB-0306	ACG	03/01/06

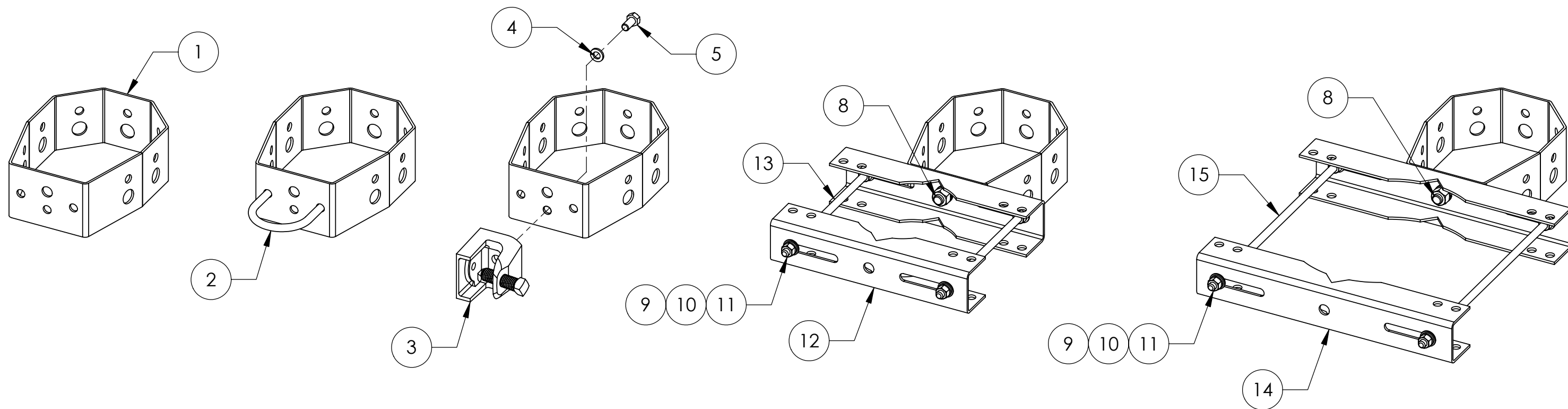

These drawings and specifications are the proprietary property of ANDREW CORPORATION and may be used only for the specific purpose authorized in writing by Andrew Corporation.

ALL DIMENSIONS ARE IN INCHES U.O.S.
TOLERANCES UNLESS OTHERWISE SPECIFIED:
.X = ± .06 ANGLES ±2°
.XX = ± .03 FRACTIONS ±1/32
.XXX = ± .010

REMOVE BURRS AND BREAK EDGES .005

DO NOT SCALE THIS PRINT

DRAWN BY: ACG	SHEET: 1 of 1	PART NUMBER: CS-B SERIES
CHECKED BY: TP	SCALE: NTS	DESCRIPTION: CLUSTER SUPPORT BRACKET
DATE: 03/01/06	MATERIAL: A36, A568, SS304	DRAWING TYPE: ASSEMBLY DRAWING
REVISION: E	FINISH: GALV A123	 ORLAND PARK, IL. 60462 U.S.A.
	WEIGHT: 15.14 LBS	