

CATALOG NO.	DESCRIPTION	WEIGHT (lbs.)
FOT-KIT-TOL-SC/ST POLISH	SC/ST POLISHING TOOL	0.01

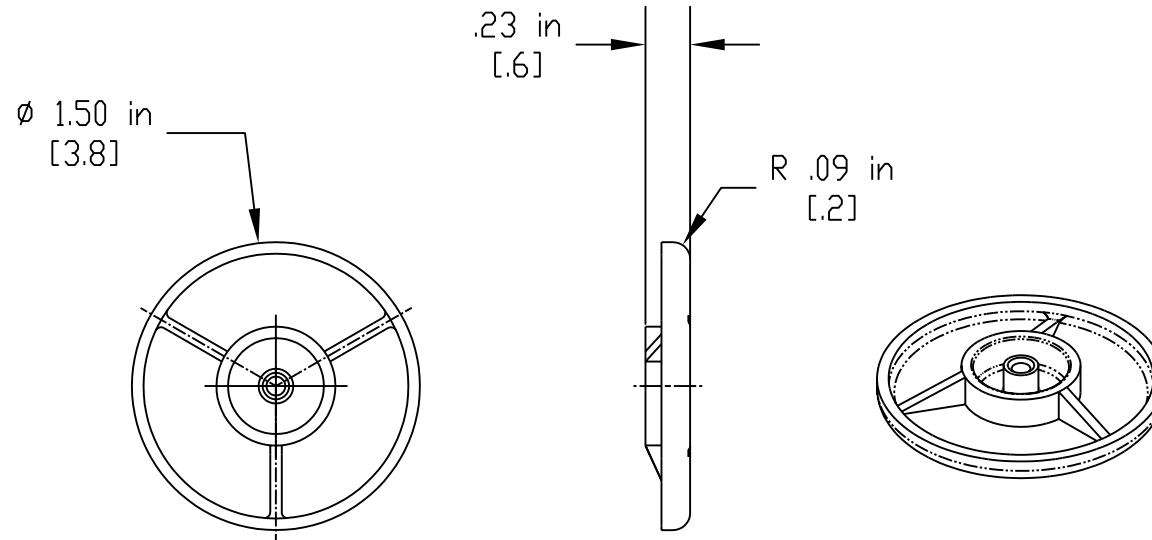

NOTES:

1. SEE UNIPRISE CATALOG FOR PART NUMBER SUFFIXES TO INDICATE COLOR/PKG.
2. SEE UNIPRISE CATALOG FOR COMPLETE LIST OF PARTS RELATED TO THE USE OF THIS PRODUCT.
3. DIMENSIONS IN PARENTHESES ARE IN METRIC.
4. MATERIAL: ENGINEERED PLASTIC

FOT-KIT-TOL-SC/ST POLISH

COMMSCOPE, INC HICKORY, NORTH CAROLINA

Uniprise

REV	DATE	ECR	DESCRIPTION	BY	DATE	DWG NO.