

TA-DFDR

7-16 DIN Female to 7-16 DIN Male Right Angle Low-PIM Adapter



Product Classification

Product Type Adapter

General Specifications

Body Style Right angle

Inner Contact Plating Silver

Interface 7-16 DIN Female

Interface 2 7-16 DIN Male

Outer Contact Plating Trimetal

Pressurizable No

Dimensions

Width 31.75 mm | 1.25 in

Length 53 mm | 2.087 in

Diameter 31.75 mm | 1.25 in

Outline Drawing

TA-DFDR

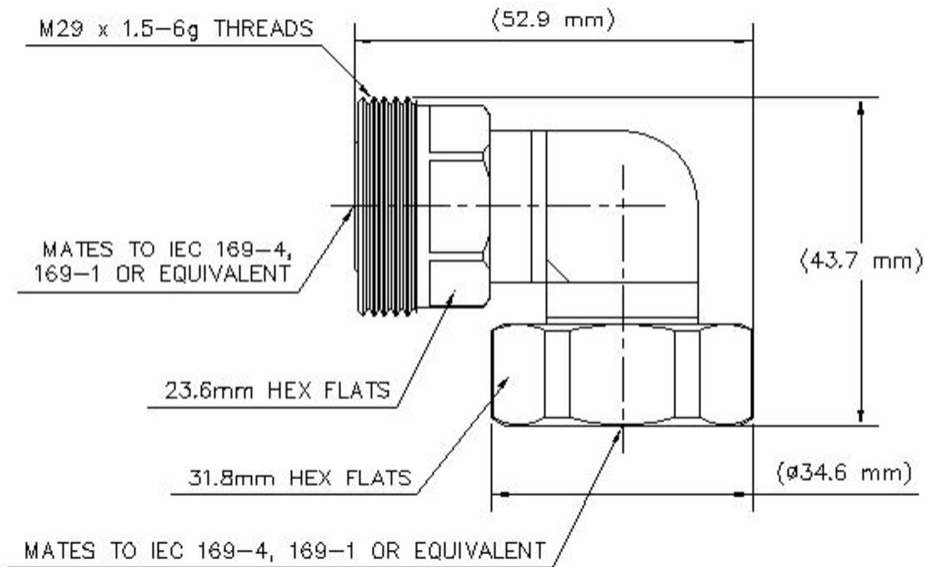

Electrical Specifications

3rd Order IMD at Frequency	-163 dBc @ 1800 MHz
3rd Order IMD Test Method	Two +43 dBm carriers
Average Power at Frequency	1,300.0 W @ 900 MHz
Connector Impedance	50 ohm
dc Test Voltage	4000 V
Inner Contact Resistance, maximum	0.4 mOhm
Insulation Resistance, minimum	10000 MOhm
Operating Frequency Band	0 – 6000 MHz
Outer Contact Resistance, maximum	1.5 mOhm
Peak Power, maximum	28.8 kW
RF Operating Voltage, maximum (vrms)	1200 V

VSWR/Return Loss

Frequency Band	VSWR	Return Loss (dB)
0-3000 MHz	1.083	27.99
3000-6000 MHz	1.173	21.98

Mechanical Specifications

Coupling Nut Proof Torque	50 N-m 442.537 in lb
----------------------------------	------------------------

TA-DFDR

Coupling Nut Proof Torque Method	IEC 61169-4:17
Coupling Nut Retention Force	800 N 179.847 lbf
Coupling Nut Retention Force Method	IEC 61169-4:15.2.6
Insertion Force	200 N 44.962 lbf
Interface Durability	500 cycles
Interface Durability Method	IEC 61169-4:17
Mechanical Shock Test Method	IEC 60068-2-27

Environmental Specifications

Operating Temperature	-55 °C to +85 °C (-67 °F to +185 °F)
Storage Temperature	-65 °C to +125 °C (-85 °F to +257 °F)
Climatic Sequence Test Method	IEC 60068-1
Corrosion Test Method	IEC 60068-2-11
Damp Heat Steady State Test Method	IEC 60068-2-3
Thermal Shock Test Method	IEC 60068-2-14
Vibration Test Method	IEC 60068-2-6

Packaging and Weights

Weight, net	171 g 0.377 lb
--------------------	------------------

Regulatory Compliance/Certifications

Agency	Classification
CHINA-ROHS	Below maximum concentration value
ISO 9001:2015	Designed, manufactured and/or distributed under this quality management system
REACH-SVHC	Compliant as per SVHC revision on www.commscope.com/ProductCompliance
ROHS	Compliant
UK-ROHS	Compliant/Exempted

