

4

3

2

1

- 1.0 GENERAL NOTES
- 1.1 ALL METRIC DIMENSIONS ARE IN BRACKETS [X.X]
- 1.2 FOR PATENT INFO: <https://www.cs-pat.com>

- 2.0 DESIGN NOTES
- 2.1 ANY HAZARDS OR OBSTRUCTIONS TO THE CLIMBING FACILITY AND SAFETY CLIMB MUST BE IDENTIFIED PRIOR TO INSTALLING THE APPURTENANCE. ADDITIONAL PRODUCTS MAY BE REQUIRED TO MAINTAIN THE INTEGRITY OF THE SAFETY CLIMB. DURING INSTALLATION, TEMPORARY AND/OR PERMANENT PRECAUTIONARY MEASURES SHOULD BE TAKEN TO PRESERVE THE CLIMBING FACILITY AND/OR SAFETY CLIMB.
- 2.2 FITS MONOPOLES 30"- 60" OD.
- 2.3 USE DCP10 FOR ROUND TUBE STAND-OFF ARM.
- 2.4 USE MTC323704 FOR RECTANGLE TUBE STAND-OFF ARM.
- 2.5 CUT THREADED RODS AS NEEDED FOR PROPER LENGTH.

- 3.0 MANUFACTURING/SPECIAL REQUIREMENTS
- 3.1 TIGHTEN ALL BOLTS SECURING FLAT PLATES BY THE TURN-OF-NUT METHOD. TIGHTEN ALL U-BOLTS USING TURN-OF-NUT METHOD WITH ATTENTION TO LEAVE EQUAL DISTANCE AND EQUAL FORCE ON EACH LEG OF THE U-BOLT.

- 4.0 TEST
- 5.0 PACKAGING
- 5.1 PACKAGING SHALL MEET COMMSCOPE REQUIREMENTS PER DOCUMENT IS-PL-3005
- 5.2 PRINTED DOCUMENT TO BE PLACED INSIDE POLYBAG AND THEN IN SHIPPING CONTAINER
- 5.3 EXTRA HARDWARE MAY BE SUPPLIED, BAGGED AND SHIPPED

REVISIONS			
REV.	DESCRIPTION	DATE	APPROVED
A	INITIAL RELEASE	MSM 22SEP14	TP
C	MT-381-10 WAS MT-381-8; GB-0550A WAS GB-0546A (MATCHED WITH BOM)	JL1183 15NOV22	SA1015 40160482CMO
D	MT-381 WAS MT-381-10	RY1002 22APR24	CB1094 40193962CMO

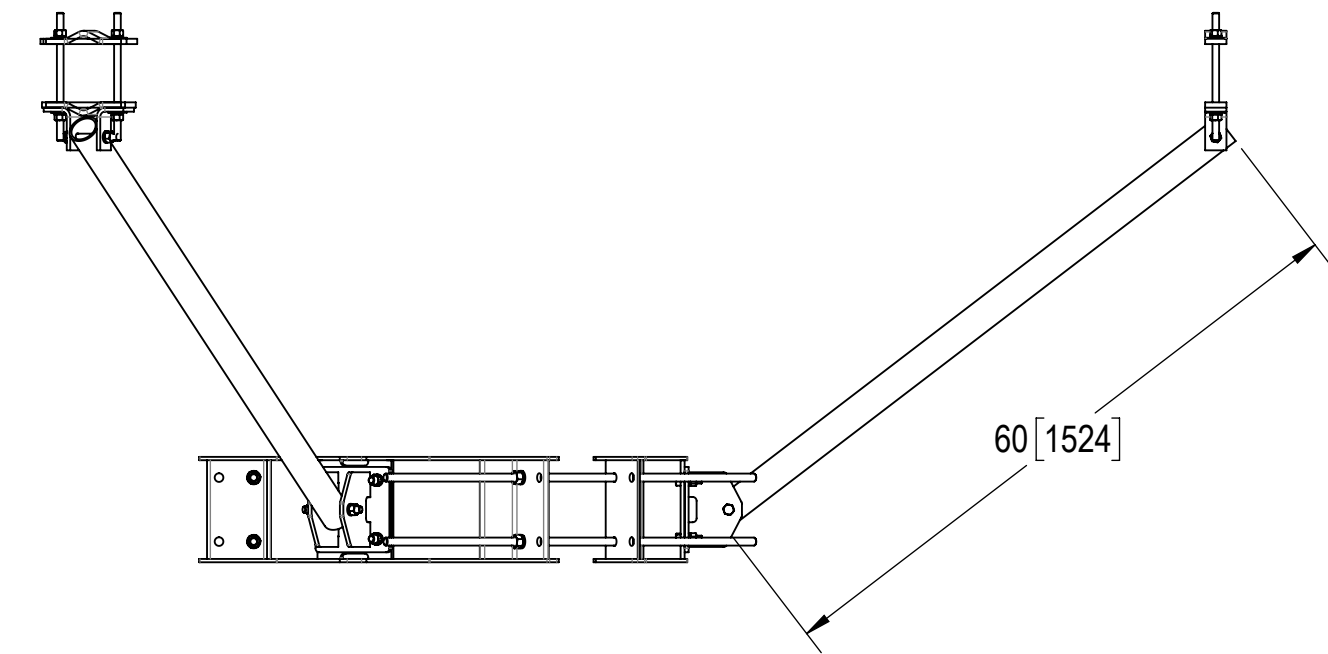
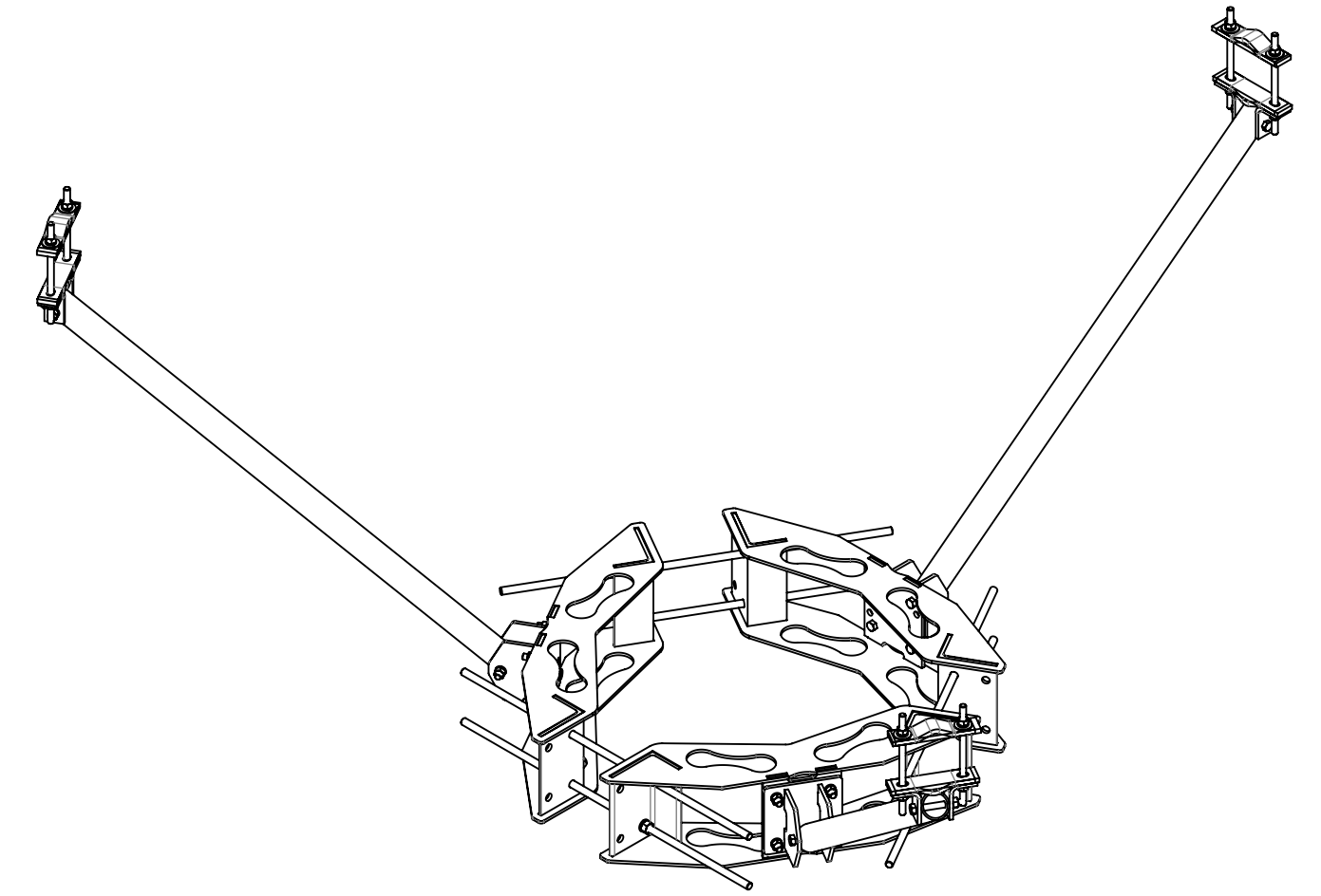
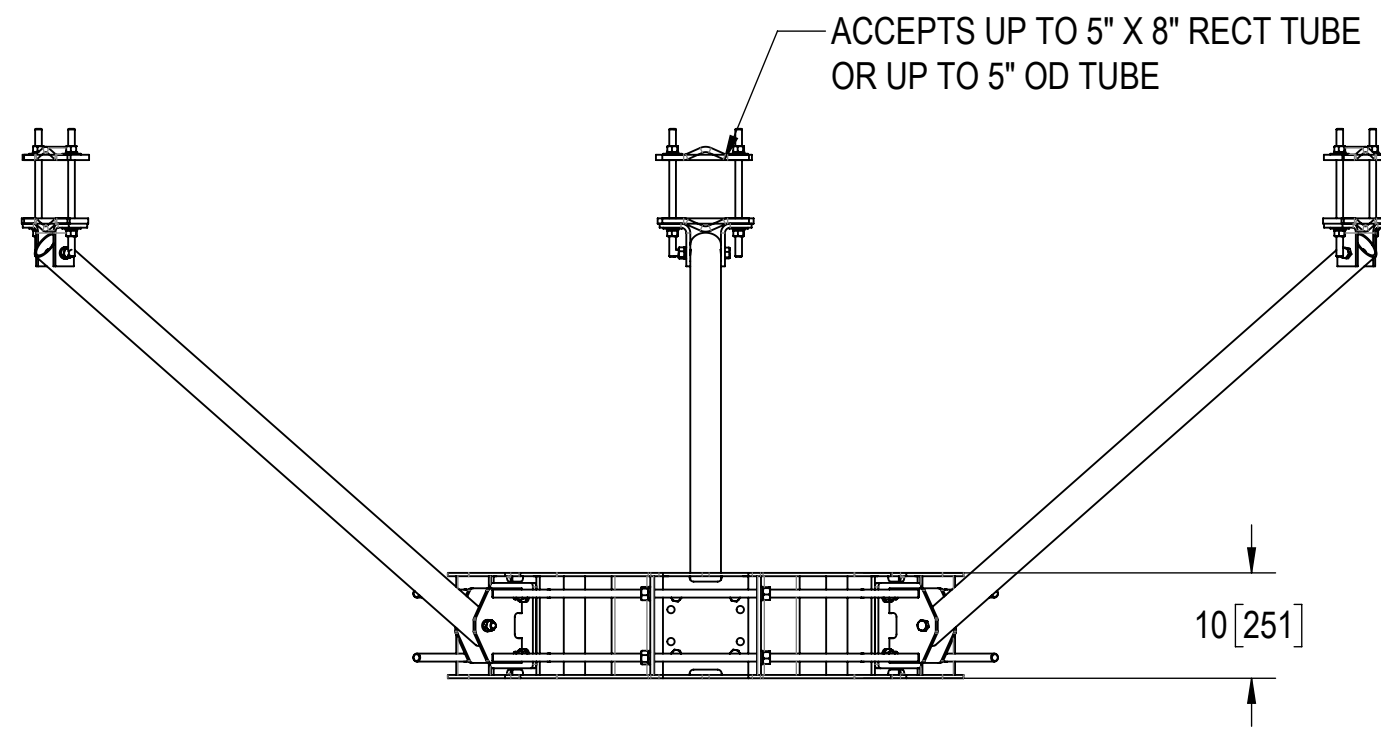
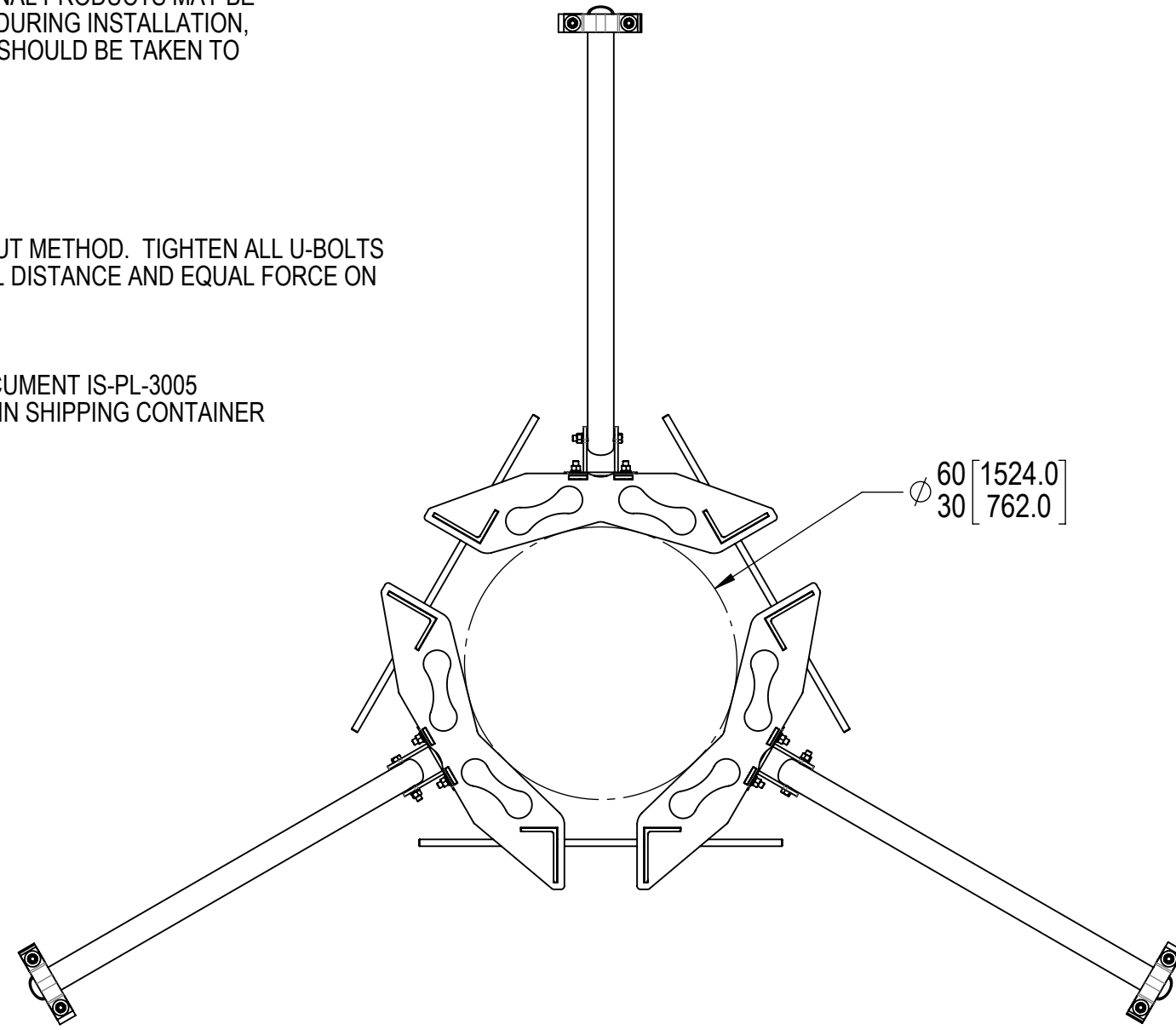

COMMSCOPE, INC. OF NORTH CAROLINA												
TOLERANCES						SAP MATERIAL MASTER						
1 PLACE .X[X] ± 0.12[3.0]			3 PLACE .XXX[X] ± 0.03[0.8]			RK-60-3L						
2 PLACE .XX[X] ± 0.06[1.5]			ANGLES ± 2°									
FINISH						MATERIAL						
UNLESS OTHERWISE SPECIFIED DIMENSIONS ARE IN INCHES INTERPRET PER ANSI Y 14.5M-1994	NAME		DATE		TITLE							
	CE	MSM	09/22/14		REINFORCEMENT KIT, 3-SECTOR, 60" ARM, 30							
	RW	RY1002	05/08/2024									
	AD	YW1047	05/11/2024									
	RE	YMENG	05/13/2024									
ECN 40193962CMO				SCALE							DOCUMENT NO.	
				1:18		RK-60-3L						
SIZE		Auth Group		INSL		MODEL			DRAWING			SHEET 1 OF 2
C						VERSION			STATUS			
				02			RE			C		
HEIGHT		60[1524]				VERSION			STATUS			
LENGTH		60[1524]				02			RE			
WIDTH		10[251]				02			D			

DENSITY		lbs/in ³
MASS	381.21	lbs
VOLUME	5986.66	in ³
SURFACE AREA	28562.30	in ²

4

3

2

1

4

3

2

1

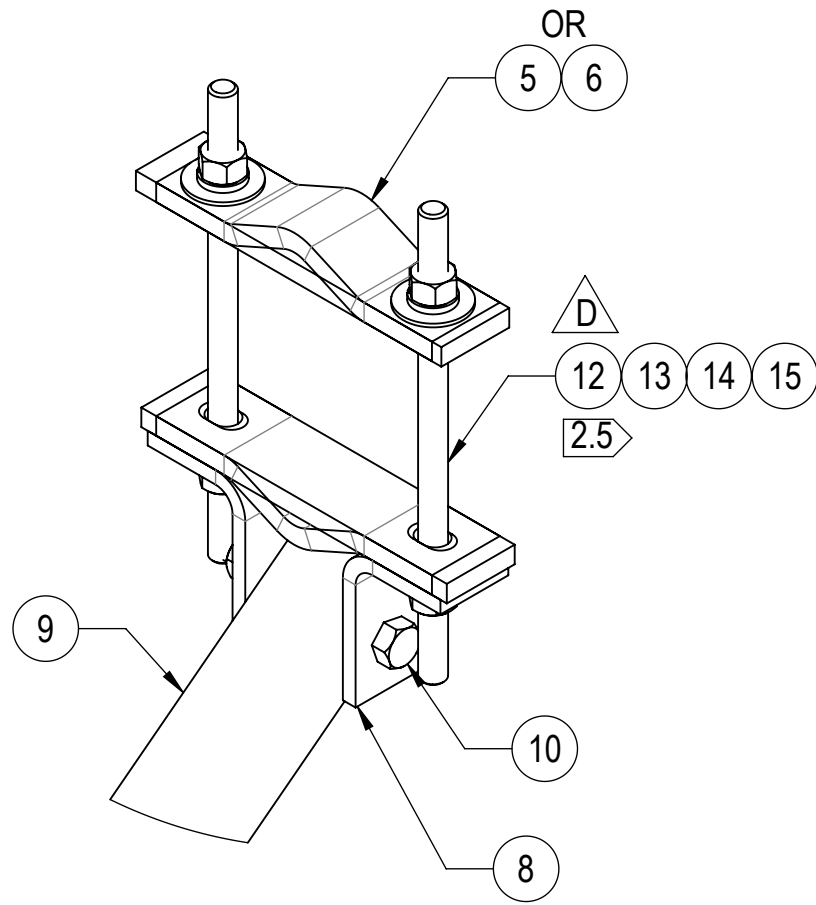
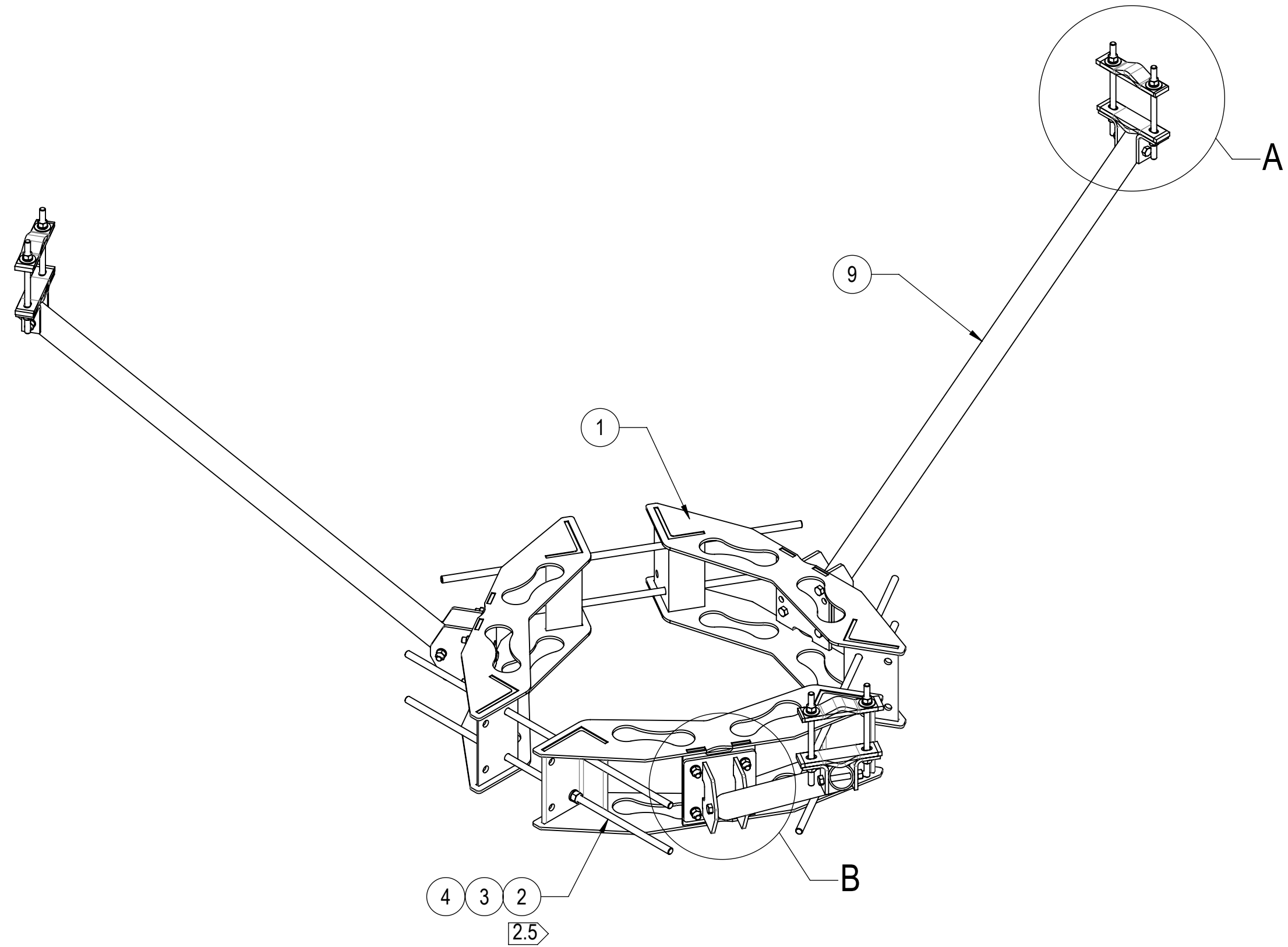

DETAIL A
SCALE 1 : 4

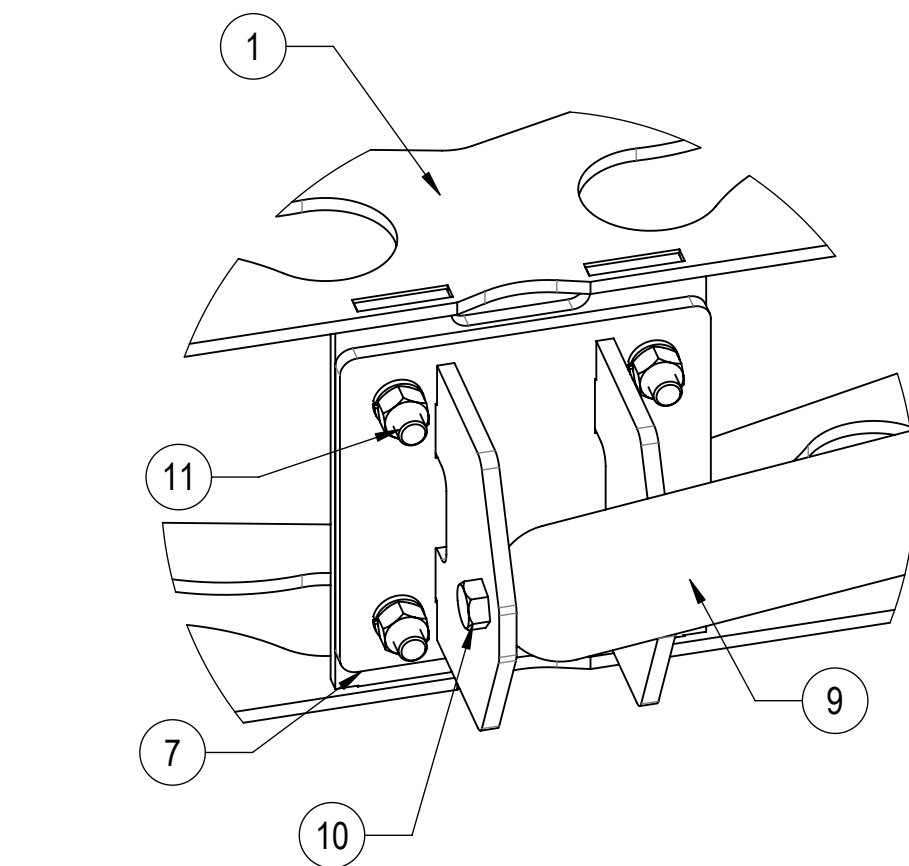

DETAIL B
SCALE 1 : 4

COMPONENT PART NUMBERS PROVIDED FOR ASSEMBLY PURPOSES;
INDIVIDUAL COMPONENTS MAY BE SHIPPED AS PARTS WITHIN AN INCLUDED KIT.

ITEM	PART NO.	DESCRIPTION	QTY.	WEIGHT	NOTE NO.
1	MTC306505W	3060 RM WELDMENT	3	58.05 LBS	
2	MT38440	3/4" X 40" GALV THREADED ROD GRADE B7	6	4.98 LBS	2.5
3	GWL-06	3/4" GALV LOCK WASHER	12	0.04 LBS	
4	GN-06	3/4" GALV HEX NUT	12	0.15 LBS	
5	DCP10	CLAMP HALF:1/2", 11/16" HOLE,5-3/4"	6	2.21 LBS	2.3
6	MTC323704	CLAMP BAR	6	2.37 LBS	2.4
7	RK01	KICKER STANDOFF WELDMENT	3	12.54 LBS	
8	RK02	CONNECTION BRACKET	6	1.21 LBS	
9	RK60	KICKER ARM SUPPORT TUBE 5'	3	28.73 LBS	
10	GB-0550A	5/8" X 5" GALV BOLT KIT (A325)	6	0.52 LBS	
11	GB-0520A	5/8" X 2" GALV BOLT KIT (A325)	12	0.26 LBS	
12	MT-381	5/8" X 12" GALV THREADED ROD	6	1.04 LBS	2.5
13	GWf-05	5/8" GALV FLAT WASHER, 1.7OD	12	0.06 LBS	
14	GWL-05	5/8" GALV LOCK WASHER	12	0.03 LBS	
15	GN-05	5/8" GALV HEX NUT	12	0.08 LBS	

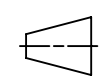
COMMSCOPE, INC. OF NORTH CAROLINA				
TITLE REINFORCEMENT KIT, 3-SECTOR, 60" ARM, 30				
SIZE C	SCALE 1:12	DOCUMENT NO. RK-60-3L		
 		DRAWING		SHEET
		VERSION 02	STATUS RE	REVISION D