

L4HMP-D Connector Installation for HELIAX® LDF4 Cables

Bulletin 7769948 Revision G Page 1 of 2

CommScope Infrastructure Academy offers installation training.



Scan For
Installation Video

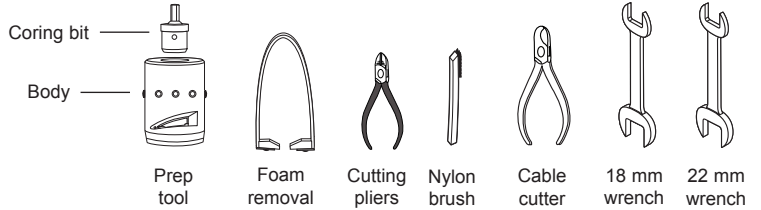
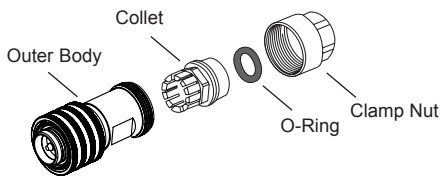

1 Straighten the cable and cut the end square using cable cutter.

6 in (152 mm)

90°

WARNING
Outer conductor edges will be sharp

2 Apply forward pressure until you feel the ball bearings land in a corrugation valley. Reverse tool to remove. End of the prep tool can be used as a guide.

0.075 in (1.90 mm)

DO NOT REMOVE FOAM FROM INNER

Prep tool
CPT-L4-D required

Operating drill speed
250-650 rpm range

3 If all of the outer jacketing wasn't removed during initial cable prep remove at this time. Slide the clamping nut over the cable end. Install pre-lubricated o-ring in the 5th corrugation.

1 2 3 4 5

4 Push the collet back over the O-ring until it stops, then release it. Verify that the collet has located into the first corrugation. **DO NOT TWIST.** Clean off face of foam with alcohol wipe.

1 2 3 4

5 To achieve optimum Return Loss, pull outer body to remove coring bit from the tool. Place bit over inner conductor and push forward until bit contacts face of foam. **BEFORE turning drill push HARD depressing foam.** Maintaining forward force, turn drill at 1/4 trigger until tool bottoms out. Clean foam from coring bit and repeat, carefully remove any loose foam with non-metallic tool.

4 MAX

6 Remove any foam dielectric and excess adhesive on inner conductor up to the end of outer conductor using provided foam removal tool. Squeeze the tool at the base of inner conductor and pull towards yourself.

Caution: Do not apply coring/flaring bit until rear collet is in place (step 4).



L4HMP-D Connector Installation

for HELIAX® LDF4 Cables

Bulletin 7769948 Revision G Page 2 of 2

CommScope Infrastructure Academy offers installation training.

7



WARNING

To achieve optimum PIM, use included alcohol wipe on the exposed inner, outer and remaining foam on the inner to remove any remaining particles. **Do not remove foam from inner.** Carefully examine ends of outer and inner conductors. If cuts are not clean or either conductor looks scratched, damaged or distorted, remove components, cut off cable and refit.



Use a new alcohol wipe. Do not re-use wipe from step #4.

For HL4RPV-50 cable snip off any damaged dielectric material with cutting pliers

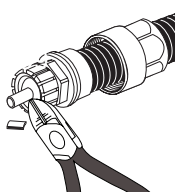

Tip: A bright flashlight can help detect particles and clean pressurized air can be useful to blow out the particles.

8

Slide the outer body over the collet and rotate slightly to align socket within the outer body with the hex edge on the collet. Push until fully engaged.

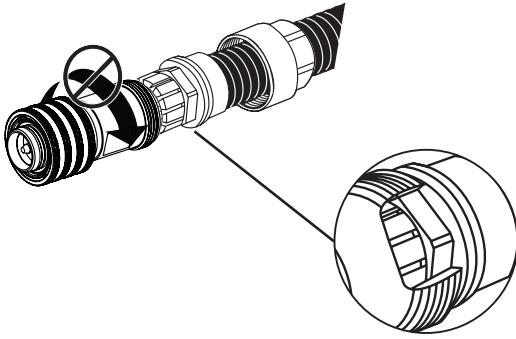
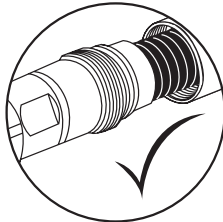
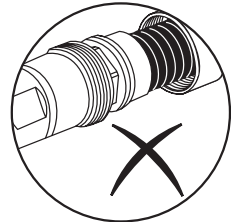
9

Slide the clamping nut up to the outer body and tighten by hand by turning the clamping nut and holding the front body stationary. Complete the installation by tightening with torque and open ended wrenches.

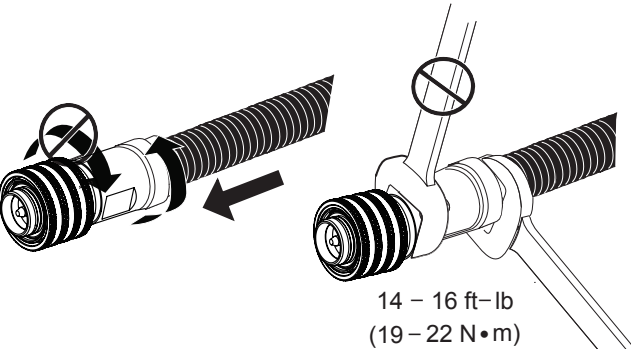

14 – 16 ft-lb
(19 – 22 N•m)

10

Assemble: Hold the connector body and push it onto the female interface, listen for a click sound to fully engage. **DO NOT** hold the coupling nut while pushing on.

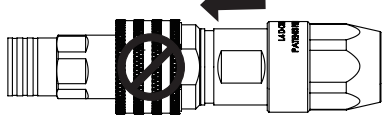

Disassemble: Hold the connector body and pull back the coupling nut to disengage.

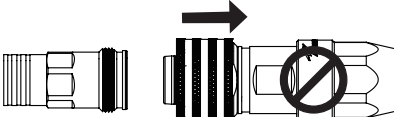

Tip:
Assemble: Rotate the coupling nut slightly to help a click sound for fully engaged.
Disassemble: Rotate the coupling nut slightly to help pull back.



Scan For Installation Video

CommScope
1100 CommScope Place SE P.O. Box 339, Hickory, NC 28603-0339
(828) 324-2200 (800) 982-1708
www.commscope.com

Customer Service 24 hours
North America: +1-800-255-1479 (toll free)
Any country: +1-779-435-6500
email: acicustomersupportcenter@commscope.com

Notice: CommScope disclaims any liability or responsibility for the results of improper or unsafe installation, inspection, maintenance, or removal practices.
Aviso: CommScope no acepta ninguna obligación ni responsabilidad como resultado de prácticas incorrectas o peligrosas de instalación, inspección, mantenimiento o retiro.
Avis: CommScope décline toute responsabilité pour les conséquences de procédures d'installation, d'inspection, d'entretien ou de retrait incorrectes ou dangereuses.
Hinweis: CommScope lehnt jede Haftung oder Verantwortung für Schäden ab, die aufgrund unsachgemäßer Installation, Überprüfung, Wartung oder Demontage auftreten.
Atenção: A CommScope abdica do direito de toda responsabilidade pelos resultados de práticas inadequadas e sem segurança de instalação, inspeção, manutenção ou remoção.
Avvertenza: CommScope declina eventuali responsabilità derivanti dall'esecuzione di procedure di installazione, ispezione, manutenzione e smontaggio improprie o poco sicure.
注意: CommScope 公司申明對於不恰當或不安全的安裝、檢驗、維修或拆卸操作所導致的後果不負責任 何義務和責任

